

História e Educação Matemática

proceedings • actes • actas

vol. I

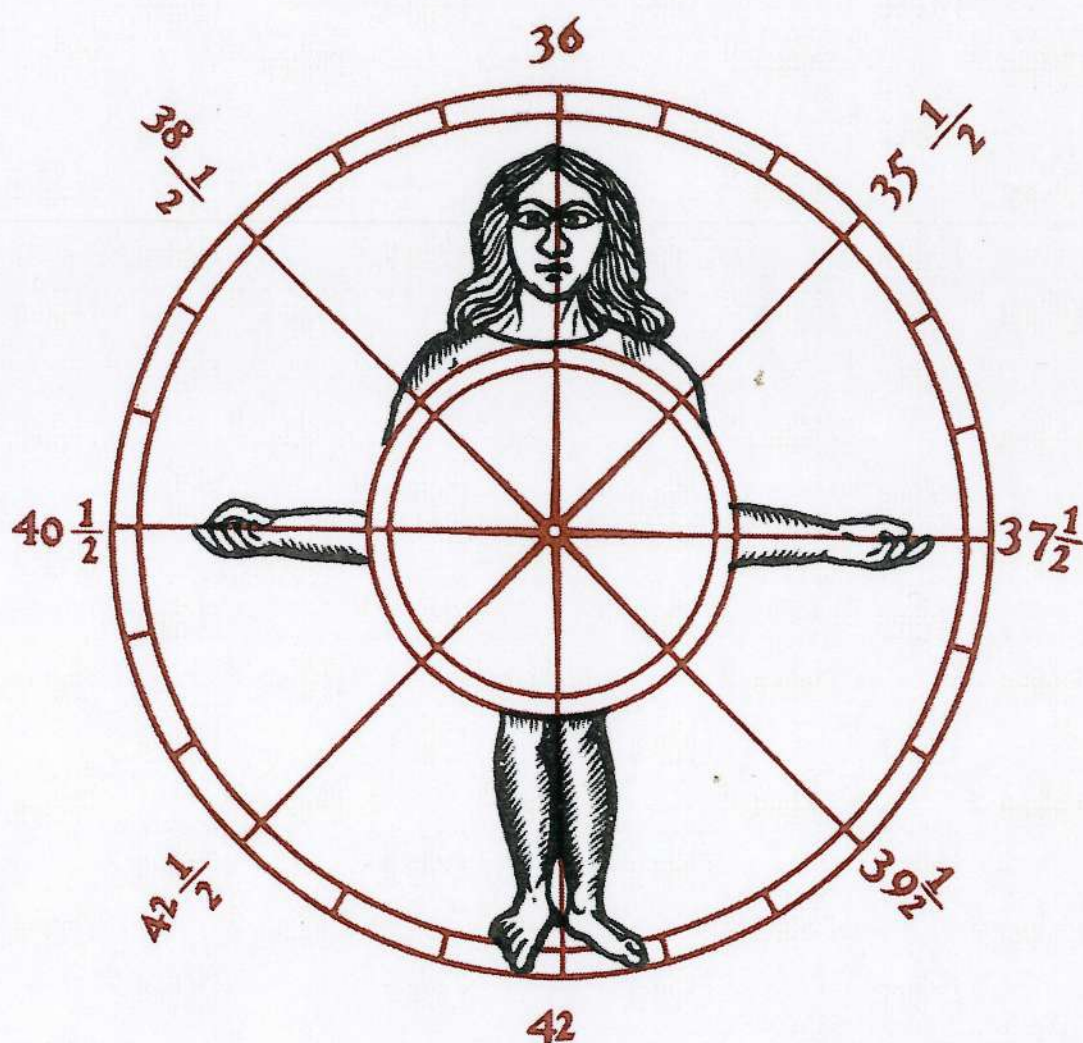

24-30 Julho 1996, Braga, Portugal

Associação de Professores de Matemática
Departamento de Matemática da Universidade do Minho

História e Educação Matemática

proceedings • actes • actas

vol. I

*Deuxième Université d'Été Européenne
sur Histoire et Épistémologie dans
l'Education Mathématique*

*ICME-8 satellite meeting of the
International Study Group on the Relations Between
History and Pedagogy of Mathematics (HPM)*

24-30 Julho 1996, Braga, Portugal

Associação de Professores de Matemática
Departamento de Matemática da Universidade do Minho

Programme Committee	Ubiratan d'Ambrosio (Brasil),	Jesús Hernández (Spain)	
Comité du Programme	Evelyne Barbin (France) (<i>joint chair</i>)	Victor Katz (USA),	
Comissão do Programa	George Booker (Australia)	Jan van Maanen (The Netherlands)	
	Jean Doyen (Bélgique)	Carlos Sá (Portugal)	
	Maria Fernanda Estrada (Portugal)	Luis Saraiva (Portugal)	
	Florence Fasanelli (USA)	Gert Schubring (Germany)	
	John Fauvel (UK) (<i>joint chair</i>)	Man-Keung Siu (Hong Kong)	
	Fulvia Furinghetti (Italy)	Eduardo Veloso (Portugal).	
	Paulus Gerdes (Moçambique)		
Organizing Committee	Manuel A. Melo Alves (Portugal)	Hélia Oliveira (Portugal)	
Comité d'Organisation	Evelyne Barbin (France, IREM)	Paulo Oliveira (Portugal)	
Comissão Organizadora	Maria José Costa (Portugal)	Maria Elfrida Ralha (Portugal)	
	Isabel Cristina Dias (Portugal)	Carlos Correia de Sá (Portugal)	
	Maria Fernanda Estrada	Maria do Céu Silva (Portugal)	
	(Portugal) (<i>joint chair</i>)	Helena Sousa (Portugal)	
	John Fauvel (UK, HPM)	Olga Maria Vaz (Portugal)	
	José António Fernandes (Portugal)	Ana Vieira (Portugal)	
	Maria João Lagarto (Portugal)	Eduardo Veloso (Portugal) (<i>joint chair</i>)	
	Maria Helena Martinho (Portugal)		
Local support	João Alves	<i>APM local organization,</i>	<i>Computing, Informatique,</i>
Appui local	Maria José Pinheiro	<i>Groupe local APM, Núcleo</i>	<i>Informática</i>
Apoio local	Luis Costa	<i>da APM de Braga</i>	<i>(data base, home page)</i>
	Elisabete Costa e Silva	Célia Lobo	Ana Rocha
	Manuel Simoes	Mário Roque	<i>Grupo de Estudos de</i>
	Carlos Vilar	Ofélia Cruz	<i>Matemática e Ciências</i>
	Sandra Vilela	Sara Rodrigues	<i>da Computação</i>
	Floriano Viseu		João Silva
			Ricardo Branco

Título: *História e Educação Matemática — Proceedings • Actes • Actas — Vol. I*

Publicadas pela Comissão Organizadora do HEM BRAGA 96

Organizadores: Maria João Lagarto, Ana Vieira e Eduardo Veloso

Data: Julho de 1996

Composição e paginação: Gabinete Técnico da APM

Nº de exemplares: 700

Montagem e impressão: Grafis, Coop. de Artes Gráficas, CRL

Nº de depósito legal: 101752/96

ISBN: 972-9053-55-3

Contents • Table des matières • Índice

- 1 **Forword • Avant propos • Introdução**
Plenary lecture • Conférence plenière • Conferência plenária
- 9 Plen1: *Pedro Nunes e as Lições de uma Época*
F. R. Dias Agudo, Academia das Ciências de Lisboa, Portugal
- Introductory Lectures • Conférences introductives • Conferências introdutórias**
- 23 IL01P: *Sobre Matemática na História da África Sub-Sahariana*
Paulus Gerdes, Universidade Pedagógica, Moçambique
- 35 IL02: *From Uruk to Babylon: 4500 years of Mesopotamian mathematics*
Eleanor Robson, Oxford University, UK
- 45 IL03: *Egyptian Mathematics*
Victor J. Katz, Un. of the District of Columbia, USA
- 54 IL05: *Mathematics in Ancient China*
Man-Keung Siu, University of Hong-Kong
- 66 IL06: *Indian Mathematics and its Evolution*
P. Rajagopal, Atkinson College, York University, Canada
- 83 IL07: *A cultura matemática encontrada pelos colonizadores nas Américas do Sul e Central*
Eduardo Sebastiani Ferreira, Universidade de Campinas, Brasil
- 102 IL08: *Algumas notas sobre a História da Matemática em Portugal*
António Leal Duarte; Jaime Carvalho e Silva; João Filipe Queiró; Departamento de Matemática, Universidade de Coimbra, Portugal
- 113 IL09: *Mathematics in South America and Central America*
Ubiratan D'Ambrosio, Universidade de S. Paulo, Brasil
- 124 IL10: *Historicité de la notion d'évidence en géométrie, entre évidence visuelle et évidence manipulatoire*
Evelyne Barbin, IREM Paris 7, France
- 136 IL11: *Qu'est-ce que l'Algèbre? Un Domaine ou un Langage?*
Jean-Paul Guichard, IREM de Poitiers, France
- 148 IL12: *The Calculus, out of the blue?*
Jan van Maanen, University of Groningen, The Netherlands
- 160 IL13: *Trigonometry*
Victor J. Katz, University of the District of Columbia, USA
- 171 IL14: *Histoire du concept de nombre*
Éliane Cousquer, Université des Sciences et Techiques de Lille, France
- 183 IL15: *The History of Non-Euclidean Geometry*
Torkil Heiede, Royal Danish School of Educ. Studies, Denmark
- 195 IL16: *History of Combinatorics*
Robin J. Wilson, The Open University, UK

- 201 IL20: *Problem Solving from the History of Mathematics*
Frank Joseph Swetz, The Pennsylvania State University, USA
- 209 IL21: *Computational devices and methods*
John Fauvel, The Open University, UK
- 213 IL23: *Mathématiques et Navigation: Le Traité de Pierre Bouguer de 1753*
Xavier Lefort, Institut Universitaire de Technologie de Saint-Nazaire, France
- 222 IL24: *Géométrie des arpenteurs de l'antiquité avec des enfants de 8 à 13 ans*
Patrice Johan, Institut Universitaire de Formation des Maîtres, Créteil, France
- 234 IL25: *Matemáticas e Técnicas*
Ubiratan D'Ambrosio, Universidade de S. Paulo, Brasil
- 241 IL26: *Music and Mathematics*
John Fauvel, The Open University, UK
- 249 IL28: *Mathematics and Culture*
José Luis Montesinos Sirera, I. B. Villalba Hervas, Sem. OROTAVA, Espanha

Panels • Tables-rondes • Painéis

Pan01: *History of Mathematics Education*

- 261 *History of Mathematics Education*
Fulvia Furingueti, Università di Genova, Italia
- 263 *Problems of research on history of mathematics education*
Gert Schubring, Universität Bielefeld, Germany
- 265 *Formative value or selection: the rise of mathematics education*
Harm Jan Smid, University of Delft, The Netherlands
- 267 *The Roots of the Curriculum: a Brief History of Mathematics Education in England*
Leo F. Rogers, Roehampton Institute, London, UK
- 269 *A history of mathematics education in Japan*
Osamu Kôta, Rikkyo University, Japan University

Pan02: *History, research and teaching of mathematics*

- 271 *History, research and teaching of mathematics: an introduction for the panel*
Luis Radford, Université Laurentienne, Canada
- 275 *History, research and teaching mathematics: case studies for linking different domains*
Fulvia Furinghetti, Università di Genova, Italia
- 277 *Les questions de l'histoire dans la recherche en didactique: éléments méthodologiques*
Guillermina Waldegg, Sec. Metodologia e Teoria de la Ciencia, CINVESTAV, México
- 282 *Epistémologie, Histoire des Mathématiques et Enseignement*
Rudolf Bkouche, IREM de Lille, France

Pan03: *Perils and Pleasures of the Internet*
291 *Panel presentation*
Jan van Maanen, University of Groningen, The Netherlands

Pan04: *Mathematical Proof in History*
293 *Panel presentation*
Jesus Hernandez, Universidade Autónoma de Madrid, Spain
Victor Katz, University of the District of Columbia, USA

Workshops • ateliers • sessões práticas

297 W02: *Comment fonctionne la géométrie algébrique*
Alain Bernard, IREM Montpellier, France

299 W03: *Une Approche Pédagogique Deducite de l'Histoire*
Alain Bernard, IREM Montpellier, France

301 W05: *Uma abordagem histórico-matemática dos fundamentos do cálculo diferencial: reflexões metodológicas*
Arlete de Jesus Brito, UNICAMP, S. Paulo; Virgínia Cardia Cardoso, UNESP, Rio Claro, Brasil

303 W07: *Pascal et le calcul intégral*
Claude Merker, IREM Besançon, France

305 W08: *The history of the relation between mathematics and physics as an essential ingredient of their presentation*
Constantinos Tzanakis, University of Crete, Greece

307 W11: *Teaching Mathematics in Somalia*
Franco Favilli; Jama Musse Jama, Università di Pisa, Italia

309 W12: *How to treat students to... conics and how to read an ancient French text at school without knowing French!*
Giuliano Testa, Liceo Scientifico "P. Liroy"- Vicenza, Italia

311 W29: *Somando frações no ábaco dos romanos e auxiliando os babilônios em divisões não exactas*
Nilza Eigenheer Bertoni ; Leda Maria Rangearo Fiorentini, Universidade de Brasília, Brasil; Grégoire, IREM, Histoire des Maths, France

313 W31: *Algorithmes numériques et géométriques pour la résolution d'équations du second degré à trois termes*
Odile Kouteynikoff, Michèle Grégoire, Maryvonne Haliez ; IREM Paris 7

315 **Sessions of HEM Braga 96 without texts included in these proceedings**
Séances de HEM Braga 96 dont les textes ne sont pas inclus dans les actes
Sessões de HEM Braga 96 cujos textos não estão incluídos nestas actas

317 **Sponsors • Commanditaires et parrains • Patrocínios e apoios**

319 **HEM BRAGA 96 participants • Participants et participantes • Lista dos(as) participantes no HEM BRAGA 96**

Foreword

The conference **História e Educação Matemática** is a joint meeting of the European Summer University on History and Mathematics Education and the International Study Group on the relations between History and Pedagogy of Mathematics (HPM). The first European Summer University was organized in Montpellier by the IREM (Research Institutes on Mathematical Education), in July 1993. HPM holds a meeting every four years immediately before or after the ICME's, in a country neighbouring the host country. This year the ICME conference is taking place in Seville, Spain, and so a fortunate set of circumstances has resulted in the decision to hold this conference in Braga, Portugal. In Portugal, as in many other countries, a movement to reform the teaching of mathematics has gained much support after the recognized failure of "modern mathematics". The Portuguese Association of Teachers of Mathematics (APM) is an offshoot of that movement and in the last decade has played a dynamic role in the renovation process. The "História e Educação Matemática" conference represents a stepping-stone in these efforts, namely by bringing the integration of history in the teaching of mathematics to the forefront. This is an issue that is of increasing concern to Portuguese teachers, a fact which their large participation at this meeting. We hope that this conference will contribute towards transforming this interest into a greater number of classroom practices and that the history of mathematics and its use in teaching will gain greater relevance in the reform process and in teacher training. Thus, it was with pleasure that APM took on the responsibility of organizing this conference with the Department of Mathematics of the University of Minho.

The major themes proposed by the Programme Committee were Mathematics in Cultures and Mathematics, Arts and Techniques, and many texts in these proceedings are related to these. Other texts address other topics also proposed by the Programme Committee: history of mathematics education, epistemological obstacles, views on mathematics and mathematical proof in history. Also a great number of texts address the issue of the integration of history in the teaching of mathematics, some of them reporting current practices, and the question of teacher training in history of mathematics.

More than 550 participants, from around 30 countries, will attend this conference. Their list is included at the end of the first volume of these proceedings.

The proceedings of the conference “História e Educação Matemática” are being published in two volumes. The first includes the texts of the plenary lecture, introductory lectures and panels. The texts of papers presented to the meeting are included in the second volume. The fact that the proceedings are being published before the conference has resulted in some limitations:

- texts not received before an advertised deadline were not included;
- format followed by authors was not always in line with the one requested, so there are some inconsistencies in letter size and page layout;
- texts were not revised by the proceedings editors.

However, we think that the advantages for conference participants in receiving the proceedings beforehand more than balance these limitations. We would like to end by thanking the authors of their response to our requests, by making efforts to send the texts ahead of deadlines.

Maria João Lagarto
Ana Vieira
Eduardo Veloso
Proceedings editors

Lisbon, July 1996

Présentation

La rencontre **História e Educação Matemática** est la réalisation conjointe de la *Deuxième Université d'Été Européenne sur Histoire et Épistémologie dans l'Éducation Mathématique* et du *ICME-8 satellite meeting* de l'*International Study Group on the relations Between History and Pedagogy of Mathematics (HPM)*

La première Université d'Été Européenne a été organisé par la Commission Inter-IREM "Épistémologie et histoire des mathématiques" à Montpellier, en juillet 1993, et succédait aux quatre précédentes universités d'été qui s'adressaient surtout aux enseignants et chercheurs français. En ce qui concerne l'HPM, ses réunions principales se réalisent tous les quatre ans, immédiatement avant ou après les ICME. Étant donné que l'ICME-8 devait avoir lieu à Seville en 1996, et que pendant la rencontre de Montpellier on a décidé que la Deuxième Université Européenne serait en 1996, c'est une conjonction heureuse de circonstances qui a conduit à la réalisation de la rencontre "História e Educação Matemática", dont les présents actes veulent être le témoin écrit.

Depuis quelques années, un nouveau mouvement pour la réforme de l'enseignement des mathématiques s'est fait jour au Portugal, et dans beaucoup d'autres pays. Ce mouvement a pris un grand essor, et l'Associação de Professores de Matemática (APM), née de ce mouvement, a beaucoup contribué à le dynamiser. Cette rencontre a certainement un grand rôle à jouer dans cette dynamisation, dans la mesure où elle met au premier plan l'intégration de l'histoire dans l'enseignement des mathématiques. Cette question suscite un très vif intérêt chez les professeurs de mathématiques portugais depuis quelques années, et leur présence nombreuse à cette rencontre en témoigne. Celle-ci peut aider à ce que cet intérêt se traduise pour un plus grand nombre d'expériences dans les salles de classes, et à donner plus de poids à l'histoire des mathématiques dans l'éducation mathématique et la formation des enseignants. C'est pourquoi l'APM a accepté avec plaisir la responsabilité d'organiser, avec le Département de Mathématiques de l'Université du Minho, cette grande rencontre.

Le Comité du Programme a établi comme thèmes majeures de la rencontre Cultures mathématiques à travers le monde et Mathématiques, arts et techniques, et plusieurs textes dans ces actes concernent ces deux sujets. D'autres textes s'adressent à d'autres thèmes proposés aussi par le Comité du Programme: histoire de l'éducation mathéma-

tique, obstacles épistémologiques, conceptions des mathématiques et démonstration mathématique dans l'histoire. Enfin, un grand nombre de textes traitent, théoriquement ou par le récit d'expériences, de l'intégration de l'histoire dans l'enseignement des mathématiques ou de la formation des enseignants en histoire des mathématiques.

Plus de 550 enseignants et chercheurs participent à cette conférence. Ils viennent d'une trentaine de pays et leur liste est incluse à la fin du premier volume des actes.

Les actes de la rencontre "História e Educação Matemática" sont publiés en deux volumes. Le premier contient les textes de la conférence plénière, des conférences introductives, des tables-rondes et des ateliers. Le deuxième volume contient les textes des communications.

La distribution des actes au début de la rencontre ne vas pas sans certaines conséquences:

- seuls ont pu être inclus les textes reçus avant une certaine date limite;
- les auteurs n'ont pas toujours suivi le format indiqué, et alors il existe des disparités de format plus au moins visibles;
- les textes n'ont pas été revus ou corrigés par les responsables de l'organisation des actes.

Nous croyons, cependant que les avantages pour les participants de pouvoir disposer pendant la rencontre de la plupart des textes compensent les inconvénients. Il nous reste remercier les auteurs des efforts qu'ils ont consentis pour envoyer dans les délais requis la plupart des textes de cette rencontre.

Maria João Lagarto

Ana Vieira

Eduardo Veloso

Responsables de l'organisation des actes

Lisbonne, juillet 1996

Apresentação

O encontro **História e Educação Matemática** corresponde à realização conjunta da *Deuxième Université d'Été Européenne* sobre *Histoire et Épistémologie dans l'Éducation Mathématique* e do ICME-8 *satellite meeting* do *International Study Group on the relations Between History and Pedagogy of Mathematics* (HPM). A primeira Universidade de Verão Europeia foi organizada pelos *Instituts de Recherche sur l'Enseignement des Mathématiques* (IREM) em Montpellier, em Julho de 1993, na sequência de anteriores universidades de verão dirigidas sobretudo para professores e investigadores franceses. Quanto ao HPM, as suas reuniões mais importantes são organizadas de quatro em quatro anos, imediatamente antes ou a seguir aos ICME's. Realizando-se o ICME-8 em Sevilha, e tendo sido decidido durante a reunião de Montpellier que a segunda Universidade de Verão teria lugar em Portugal, em 1996, foi assim um conjunto feliz de circunstâncias que conduziu ao encontro sobre História e Educação Matemática de que estas actas pretendem ser um testemunho escrito.

Nos últimos anos tem-se assistido em Portugal — tal como em muitos outros países — a um novo movimento de reforma do ensino da matemática. A Associação de Professores de Matemática (APM), foi produto deste processo e tem desempenhado nos seus dez anos de vida um papel dinamizador dos esforços de renovação. O encontro “História e Educação Matemática” constitui um marco importante nessa dinâmica, nomeadamente ao chamar para primeiro plano a integração da história no ensino da matemática. Esta é uma questão que tem despertado nos últimos anos um grande interesse por parte dos professores de matemática portugueses, o que justifica a presença de mais de três centenas neste encontro. Este encontro poderá ser um contributo importante para que esse interesse se concretize num maior número de experiências na sala de aula, e para que o tema da história e da sua utilização no ensino da matemática adquira maior relevo naquele movimento de reforma e mesmo na formação de professores. Foi portanto com satisfação que a APM aceitou a responsabilidade de organizar este grande encontro, em conjunto com o Departamento de Matemática da Universidade do Minho.

A Comissão do Programa definiu como principais temas do encontro *Culturas matemáticas de todo o mundo* e *Matemática, artes e técnicas*, a que se referem muitos dos textos incluídos nestas actas. Outros textos abordam outros tópicos sugeridos também

pela Comissão do Programa: *história da educação matemática, obstáculos epistemológicos, concepções da matemática e a demonstração matemática na história*. Finalmente, um grande número de textos discutem, de um ponto de vista teórico ou relatando experiências, a integração da história da matemática no seu ensino ou a formação de professores em história da matemática.

No encontro participam mais de 550 professores e investigadores de cerca de 30 países. A sua lista está incluída no fim do primeiro volume destas actas.

As actas do encontro “História e Educação matemática” são publicadas em dois volumes. No primeiro volume incluem-se textos relativos à conferência plenária, às conferências introdutórias, aos painéis e às sessões práticas. O segundo volume é totalmente preenchido com textos de comunicações. O facto das actas terem sido organizadas e impressas de modo a ser distribuídas no início do encontro conduziu naturalmente a algumas limitações:

- foi apenas possível incluir os textos recebidos dentro de uma anunciada data limite;
- os autores nem sempre formataram os textos de acordo com as instruções, pelo que existem algumas disparidades no tamanho da letra e na mancha utilizada;
- os textos não foram revistos para publicação pelos organizadores, pois foram entregues no formato para impressão.

Entendemos, no entanto, que as vantagens para os participantes de receber imediatamente, antes do encontro, a grande maioria dos textos compensam as referidas limitações. Resta-nos agradecer aos intervenientes o modo como corresponderam ao nosso pedido, enviando a maior parte dos textos com suficiente antecedência.

Maria João Lagarto

Ana Vieira

Eduardo Veloso

Responsáveis pela organização das actas

Lisboa, Julho de 1996

plenary lecture
conférence plénière
conferência plenária

PEDRO NUNES E AS LIÇÕES DE UMA ÉPOCA

F. R. Dias Agudo, Academia das Ciências de Lisboa, Portugal

1. Introdução. Do Estudo Geral de D. Dinis a D. Manuel I

Como é bem sabido, Portugal é uma das mais antigas nações da Europa. Tendo nascido no século XII, ao mesmo tempo que as primeiras “universitates magistrorum et scholarium”, a nação portuguesa veio a ter também a sua universidade (o chamado “Estudo Geral”) no fim do século XIII, precisamente no reinado de um dos nossos soberanos que mais se preocuparam com o desenvolvimento cultural do País — o rei D. Dinis, ele próprio um grande poeta. Não se conhecem quais as matérias incluídas nos “curricula”, mas há referências a três Faculdades — Medicina, Direito e Artes — e, em relação a esta última, referências à Gramática, à Lógica (ou Dialéctica) e à Música. Do “trivium” medieval não estaria, pois, presente a Retórica, e do “quadrivium” nada sobre Aritmética, Geometria e Astronomia.

Um século mais tarde, com D. João I e sua esposa D. Filipa de Lencastre a darem ao País uma plêiade de descendentes, a corte de Portugal voltou a ser “marcada por um grande apego à cultura, com a ínclita geração de príncipes a traçar ao País um novo rumo histórico”.⁽¹⁾ E o Infante D. Henrique, tornado protector da Universidade, pretendeu introduzir então as disciplinas do “quadrivium” que aí faltavam, mas os documentos conhecidos mostram que a iniciativa não teve consequências visíveis. Só com D. Manuel I, já nos alvares do século XVI, um novo plano de estudos criou a cadeira de Astronomia (com uma lição por semana) mas foram dois médicos de el-rei que a vieram a leccionar.

É que a astrologia médica (em que acreditavam Cláudio Ptolomeu e Galeno, no século II d.C.) era ainda quase universalmente aceite na Europa medieval, e essa crença de que cada órgão do corpo humano era influenciado por um dado astro acabou por ser mais um motivo (a juntar a outros) para o desenvolvimento da astronomia, e uma razão para a medicina se ligar à matemática durante séculos. Os futuros médicos recebiam lições de astronomia por se aceitar a influência dos astros no tratamento das doenças e a mais antiga universidade europeia — a de Bolonha — criou logo no século XII uma “Escola de Matemática e Medicina”.

Numa análise global do que foi o desenvolvimento científico na Europa durante a Idade Média, diremos que até ao século XI a ciência não fez aí grandes progressos. Por um lado, com a invasão dos bárbaros, no século V, os sistemas de educação greco-latinos foram completamente destruídos e só um ou outro clérigo, recolhido nalgum eremitério, se dedicaria à cultura literária; por outro, no mundo cristão predominavam então as preocupações de ordem espiritual, com acentuado dogmatismo e toda a confiança na autoridade em desfavor do que se passava no mundo que nos rodeia. “Discutir a natureza e a posição da Terra não nos ajuda na nossa esperança de vida futura” — dizia Stº Ambrósio, Padre da Igreja latina que viveu entre 340 e 397.

Só nos fins do século XI a atmosfera intelectual da Europa medieval começou a ser

(1) J. Veríssimo Serrão, *História de Portugal*, vol. I, p. 313 e vol. II, pp. 11-12 e 299.

favoravelmente afectada pelos numerosos contactos que resultavam das viagens e do comércio entre os povos, surgindo um interesse extraordinário pela obra dos gregos, através dos escritos árabes, e nascendo as primeiras universidades a que atrás nos referimos como associações de mestres e alunos, e com professores cedidos pelas ordens religiosas. Mas o ensino universitário caracterizava-se por uma obediência a textos escritos (refiram-se as *Summulae logicales* do português Pedro Hispano, que veio a ser o Papa João XXI, compêndio do século XIII seguido na maior parte das escolas até ao século XVI; o *Liber Abaci*, de Fibonacci e o *Tractatus de Sphaera*,⁽²⁾ de Sacrobosco, também do século XIII e utilizados durante séculos), submissão dos docentes ao já sabido, pela ausência de ensino prático, pela falta de criação original. Era o que passou a chamar-se, com Montaigne, um ensino livresco.

Como escreveu o grande professor da Universidade de Coimbra e membro ilustre da Academia das Ciências de Lisboa Joaquim de Carvalho, falecido em 1958, “todos os mestres, quaisquer que fossem os objectos dos seus estudos, coincidiam na mesma concepção do Mundo, na aceitação dos mesmos valores vitais e morais, na adesão à mesma teoria da ciência, considerada como hierarquia de géneros e de espécies. Para todos e para cada um, Ptolomeu exprimira o sistema do Universo, Aristóteles ensinara a filosofia que tornava inteligível o Mundo, Justiniano compilara as normas supremas da vida jurídica, Galeno e Hipócrates estabeleceram as regras da vida sã e do restabelecimento da saúde, S. Tomás de Aquino sistematizara o que se devia crer e porque se devia crer”.⁽³⁾

E esta cultura filosófico-teológica, este sentido da actividade docente das escolas medievais, que ficou conhecido por “Escolástica”, prolongou-se até tarde. Daí o não ser fácil encontrar, entre os séculos V e XV, mais do que uma dezena de cultores da matemática dignos de nota — um por século!

Dentro deste período salientou-se Leonardo de Pisa (Fibonacci) que, nascido no último terço do século XII, foi o matemático mais produtivo da Idade Média. Se deu alguma contribuição original (ainda hoje são referidos os números de Fibonacci), ficou mais conhecido por um grande trabalho de compilação. O seu *Liber Abaci*, já atrás referido, aparecido em 1202 e reeditado em 1228, continha muito do material que o autor aprendera nas suas viagens pelo Mediterrâneo, Egipto, Síria, Grécia e Sicília (de uma família de negociantes era ele próprio um mercador) e manteve-se como um modelo durante dois séculos. Para o fim do século XV, e dispondo já da imprensa, surge a *Summa de Arithmetica, Geometria, Proportioni et Proportionalita* do franciscano Luca Pacioli — livro que, em seis centenas de páginas escritas em italiano, continha o que era conhecido naquela altura sobre geometria, aritmética comercial, álgebra e trigonometria; e é a comparação entre as duas obras que mostra que não houvera progressos sensíveis nos três séculos que as separam.

Entretanto surgira, por volta de 1400, o período da Renascença, com todo um estudo crítico do conhecimento grego e romano e o declínio da autoridade dos escolásticos. A invenção da imprensa com caracteres móveis, em 1400, facilitava enormemente a difusão de conhecimentos e o movimento renascentista, nascido em Itália, logo se transmite a

(2) A astronomia do “quadrivium” era conhecida por “sphaeric”, designação que vinha de Pitágoras.

(3) Joaquim de Carvalho. *Obra Completa*, F.C. Gulbenkian, III, p. 337.

outros países. Voltara o clima de curiosidade intelectual característico dos gregos do período clássico e ansiava-se pela criação de coisas novas.

Ao mesmo tempo os Descobrimentos portugueses davam um contributo de monta para o novo ambiente sócio-cultural e económico da Europa. O desenvolvimento das actividades bancárias e comerciais exigia uma aritmética melhorada; e uma vez que Lisboa se tornara num dos maiores centros de comércio, tal necessidade não podia deixar de se fazer sentir em Portugal, o que explica que, entre nós, a primeira obra de matemática a beneficiar da invenção de Gutenberg tivesse sido o *Tratado da Prática Darismética*, de Gaspar Nicolas. Publicada em 1519 e mantida em uso por dois séculos, com uma dúzia de edições, inspirava-se na *Summa* de Luca Pacioli, com método expositivo-repetitivo à base da resolução de problemas concretos, mas com pequenas modificações para adaptar algumas das questões à nossa realidade.

2. Contribuição dos Descobrimentos para o desenvolvimento científico. Portugal na época de D. João III.

A grande revolução científica de Kepler, Bacon, Galileu, Descartes e outros, culminando com a síntese genial de Newton, estava para vir, mas as navegações portuguesas até paragens longínquas, os estudos com elas relacionados (localização de uma caravela sobre os oceanos, cartografia de novas terras, cálculo de distâncias, magnetismo terrestre, correntes marítimas, regime de ventos, plantas medicinais), os mitos que destruíram (inabitabilidade das zonas tropicais e existência de monstros no mar oceano, por exemplo) contribuíram significativamente para criar o ambiente que a tornou possível — “a ciência deixava de ser a tradição que se transmite para se tornar o conhecimento que se adquire”, novamente nas palavras de Joaquim de Carvalho.⁽⁴⁾

É neste contexto de pré-revolução científica que surgem, por volta de 1500, os novos Estatutos de D. Manuel I para a Universidade Portuguesa e pelos quais é introduzida a cadeira de Astronomia, como referimos. Mas é sobretudo com seu filho D. João III, que lhe sucedeu em 1521, que se inicia entre nós uma nova era intelectual. Sem necessidade de modificar aqueles Estatutos, ele acabou por promover uma profunda reforma cultural ao proteger a instrução média e superior com grande energia, ao chamar da Europa numerosos doutores (portugueses aí estabelecidos ou estrangeiros, como o humanista e pedagogo flamengo Nicolau Clenardo), ao patrocinar o envio de bolseiros para fora do País.

Foram contemporâneos de D. Manuel I e/ou de D. João III, vivendo assim no chamado Século de Ouro da História de Portugal, figuras da nossa cultura tão importantes como, nas letras, Gil Vicente, Bernardim Ribeiro, Sá de Miranda, André e António de Gouveia, Diogo de Gouveia Senior, Garcia e André de Resende, João de Barros, Damião de Gois, D. Jerónimo Osório, Fr. Bartolomeu dos Mártires, Fr. Heitor Pinto e ... Luis de Camões; e com trabalhos de índole científica (embora alguns tenham sido filósofos, teólogos, canonistas), Duarte Pacheco Pereira (para quem “a experiência era a madre de todas as cousas”), D. Francisco de Melo (de quem Gil Vicente escreveu “sabe sciencia avondo”),

(4) *Obra Completa*, V, p. 306-307.

Álvaro Tomás (que Rey Pastor considerava uma das duas realidades brilhantes da matemática ibérica do século XVI ⁽⁵⁾ e autor de um tratado célebre, *Liber de triplice Motu*, de 1509, dedicado à cinemática), Gaspar Nicolas (oportunamente referido a propósito do seu *Tratado de Aritmética*, de 1519), Pedro Margalho (que escreveu um *Compêndio de Física*), Amato Lusitano (médico insigne), Garcia de Orta (médico e naturalista, autor do célebre *Colóquio dos Simples e drogas e cousas medicinais da Índia*), D. João de Castro (um precursor da geofísica experimental, com a sua experimentação sistemática sobre a variação magnética) e ... Pedro Nunes (a outra realidade, mais brilhante ainda, da matemática ibérica do século XVI ⁽⁵⁾).

E uma primeira lição podemos tirar (para o meu próprio País):

Se a gesta dos descobrimentos constitui um exemplo esclarecedor da capacidade dos portugueses para a criação científica e tecnológica, ela mostra igualmente (por comparação com outras épocas) como é essencial a vontade política dos governantes para que a sua criatividade se desenvolva e frutifique.

Embora tenha de se apontar a D. João III, como acção negativa, o estabelecimento da Inquisição em Portugal, “a sua obra pedagógica foi colossal para a época”, ⁽⁶⁾ notável o esforço dispendido para a maior renovação cultural que até então se verificou no País — e isto apesar de serem já grandes as dificuldades para manter um império cujos domínios se estendiam pelas cinco partes do Mundo.

E daí uma segunda lição importante:

Mesmo em tempo de dificuldades económicas, um país só tem a ganhar se não escassearem os recursos para a melhoria da qualidade de todos os níveis do ensino, para o estabelecimento de condições favoráveis à criação científica e cultural.

E passemos a

3. Pedro Nunes e a sua Obra

Como referimos oportunamente, do século V até aos finais do século XV não houve progressos sensíveis na matemática. Há mesmo quem considere que, nesta área, foi Cardan quem estabeleceu a passagem da Idade Média para a modernidade com a sua *Ars Magna* de 1545, na qual, além de outros resultados, apresentou os de Scipio del Ferro e Tartaglia para a resolução das equações do terceiro grau, não estudadas até então.

Nascido em 1501, Cardan formou-se em medicina (na Universidade de Pavia) e faleceu em 1576.

Com o *De triplice Motu* (1509) de Álvaro Pais, com a *Pratica Darismética* (1519) de Gaspar Nicolas e outras obras análogas, pode dizer-se que, quanto à actualidade com que as matérias eram tratadas, a matemática não destoava, em Portugal, do que se passava além fronteiras. Mas a figura cimeira, o grande expoente da matemática portuguesa da época de Quinhentos, viria a ser Pedro Nunes.

Contemporâneo de Cardan (nasceu em Alcácer do Sal, a Salacia dos romanos, em 1502 e faleceu em 1578), foi médico como ele; mas ao contrário do italiano (que praticou

(5) Sixto Rios e outros, *Julio Rey Pastor matemático*, Instituto de España, 1979, pp. 178-180.

(6) Ferreira Deusdado, *Educadores Portugueses*, Lello & Irmão Ed. 1995, p. 182.

a astrologia na corte papal) e de muitos outros, tomou uma atitude crítica perante a astrologia: numa das suas obras refere-se à astronomia como “ciência que se ocupa do curso dos astros e da universal composição do céu, que não da credence vã e já quase rejeitada que emite juízos sobre a vida e a fortuna”.⁽⁷⁾

E deveriam meditar nesta atitude os que hoje, e não são poucos, voltaram a comportamentos cada vez mais anticientíficos, com um irracionalismo crescente, a juntar a uma popularidade cada vez maior de pseudociências, como a referida astrologia.

Pedro Nunes obteve o grau de bacharel em medicina em 1523 pela Universidade de Salamanca — onde casou e ficou a ganhar a vida como clínico — e só não completou aí a licenciatura (que veio a terminar em Lisboa, bem como o doutoramento, em 1532) porque D. João III o mandou chamar para a corte em 1526-1527.

O rei quis o médico Pedro Nunes junto dele porque se preocupava com a saúde da rainha D. Catarina e só depois — como opinou Vicente Gonçalves em comunicação à Academia das Ciências de Lisboa⁽⁸⁾ — se deu conta de que “o médico lhe seria autorizado conselheiro para a renovação do ensino das artes no Estado e bem fadado mestre para o infante D. Luís” (então com uns 20 anos). E a estima que veio a ter por ele, o apoio que sempre lhe deu, proporcionando-lhe ambiente e meios para se entregar aos seus trabalhos (embora muitas vezes demasiado dispersivos), veio a ser determinante para a sua brilhante carreira de cientista.

Foi assim que Pedro Nunes se tornou mestre, na corte, do infante D. Luís (em cursos de que vieram a beneficiar D. João de Castro, a que já nos referimos, e Martim Afonso de Sousa, navegador e guerreiro) e, mais tarde, do infante (depois cardeal) D. Henrique; professor de Filosofia Moral, Lógica e Metafísica, a partir de 1529 e por poucos anos, no Estudo Geral de Lisboa (certamente em ligação com a renovação do ensino das artes em que o rei estava interessado); cosmógrafo (a partir de 1529) e cosmógrafo-mor do Reino (com este último lugar desde 1547 até à sua morte, em 1578). Entretanto D. João II transferira, em 1537, a Universidade para Coimbra e criara nela uma cadeira de Matemática (no curso de Medicina), encarregando também Pedro Nunes da sua regência (de 1544 até à sua jubilação, com 60 anos de idade, mas com numerosas interrupções, pois o professor era constantemente chamado para servir na corte).

Profundo conhecedor dos trabalhos de astronomia e matemática de gregos e árabes, bem como da ciência do seu tempo, designadamente dos escritos de Pacioli, Cardan, Tartaglia, não os aceitava sem crítica, comentando-os, favoravelmente ou não, e aperfeiçoando os seus resultados sempre que julgava que era caso disso.

Nos seus trabalhos foi motivado por questões bem práticas, interessou-se por problemas essencialmente teóricos, investigou matérias por simples curiosidade intelectual, própria ou dos discípulos, como veremos.

Assim:

a) Para esclarecer dúvidas que lhe foram postas, em 1533, pelo antigo discípulo Martim Afonso de Sousa ao regressar de uma longa viagem pelas costas do Brasil, Pedro Nunes

(7) Pedro Nunes, *Obras*, edição da Academia das Ciências de Lisboa, Vol. II, p. 149 (tradução do latim).

(8) “Passos de Pedro Nunes ao serviço do Rei”, *Memórias da A.C.L.*, XXVI, 1984-1985.

escreveu o seu primeiro trabalho original: *Tratado sobre certas duvidas de navegaçam*, que dirigiu ao rei; mas não satisfeito com ele, resolveu aprofundar a matéria e daí resultou o *Tratado em defensam da carta de marear com o regimento da altura*.

Nestas obras desenvolveu o problema da altura do pólo, emendou muitos erros antigos e modernos e iniciou, a propósito da representação cartográfica das novas terras que se iam descobrindo, o estudo das curvas que então se chamavam linhas de rumo e Snellius veio a designar, já nos princípios do século XVII, por luxodrómicas. Se, com elas, se pode considerar um precursor de Mercator, dez anos mais novo do que ele, deve reconhecer-se, no entanto, que Nunes ficou longe dos estudos que conduziram este matemático e geógrafo flamengo à moderna cartografia científica.

As matérias dos seus dois primeiros tratados foram novamente desenvolvidas e publicadas em latim com o título *De arte atque ratione navigandi* (“Como se ha de navegar per arte e per razão”), obra aparecida em Basileia em 1566 e reeditada em Coimbra em 1573.

No *Tratado em defensam da carta de marear* escreveu Pedro Nunes: “Ora manifesto he que estes descubrimentos de costas: ylhas: e terras firmes: nam se fizeram indo acertar: mas partiam os nossos mareantes muy ensinados e prouidos de estormentos e regras de astrologia ⁽⁹⁾ e geometria: que sam as cousas de que os Cosmographos ham dãdar apercebidos: segũdo diz Ptolomeu no primeiro liuro da sua Geografia”.⁽¹⁰⁾

E aqui se deve exaltar, pois, como nova lição a tirar daquela época, a preparação cuidada das actividades a empreender em desfavor do improvisado (que algumas vezes é superficialidade) tão do agrado de muitos portugueses de hoje.

Pelos Regulamentos do Cosmógrafo-mor de 1559 (de Pedro Nunes) e 1592 (Com ele já desaparecido mas que deve ter sido influenciado pelo primeiro) fica-se a saber como o ensino da náutica em Portugal estava bem estruturado, comprovando a nossa acção pioneira na criação e desenvolvimento da navegação astronómica e fabrico das correspondentes cartas e instrumentos náuticos.⁽¹¹⁾

As teorias de Pedro Nunes nem sempre tiveram a aceitação dos pilotos. É certo que uma ou outra vez errou (como quando atribuiu o valor de 4° e 9' ou 10' em vez de 3 graus e meio ao desvio da Estrela Polar em relação ao pólo). Mas o que também sucede algumas vezes é que, por um lado, as soluções teóricas não são facilmente transponíveis para a prática e, por outro, nem sempre é fácil vencer a resistência dos que se julgam mais experimentados. Refira-se, por exemplo, que o método proposto por Pedro Nunes para a obtenção da latitude pela determinação de duas alturas não meridianas do Sol foi experimentado com êxito pelo seu discípulo D. João de Castro, mas abandonado depois por exigir operações fora do alcance dos pilotos menos hábeis.⁽¹²⁾

E aqui se regista uma lição mais para os nossos dias:

Para que as tecnologias criadas ou adaptadas pelo potencial científico e técnico de

(9) Designação que então se dava à astronomia.

(10) Pedro Nunes, *Obras*, ed. A.C.L., Vol. I, p. 176

(11) A. Teixeira da Mota, “Os regimentos do cosmógrafo-mor de 1559 e 1592 e as origens do ensino náutico em Portugal”, *Memórias A.C.L.*, XIII, 1969.

(12) Luís de Albuquerque, “Ciência Náutica Portuguesa” in *Dicionário de História de Portugal* dirigido por Joel Serrão, I, p. 581

um país venham a contribuir, efectivamente, para o seu desenvolvimento e bem estar social do povo é necessário que este tenha um grau de instrução adequado que lhe permita beneficiar das conquistas da ciência. ⁽¹³⁾

b) Quanto ao interesse por problemas bem teóricos, sem qualquer aplicação prática em perspectiva, basta citar a sua obra *De Erratis Orontii Finaei* (de 1546), em que mostrou que as soluções dadas pelo professor parisiense para a quadratura do círculo, duplicação do cubo e triseção do ângulo eram todas falsas; e é o próprio Pedro Nunes, autor de grande probidade, que escreve no Prefácio: “... me não moveram propósitos hostis, mas a satisfação que a explicação da verdade proporciona, pois nada importa tanto ao matemático como a defesa da doutrina que professa e da maneira por que a alcançou”. ⁽¹⁴⁾

c) Pelo que respeita a investigações sobre temas postos por simples curiosidade intelectual, destaque-se o que escreveu na sua obra *De Crepusculis*, na carta-prefácio a D. João III datada de 17 de Outubro de 1541: “Com muito zelo e em pouco tempo aprendeu êle (o vosso muito esclarecido irmão o Infante D. Henrique) [...] tôda a Cosmografia, e a prática de alguns instrumentos antigos e de outros ainda que eu havia inventado para a arte de navegar [...] o que (o ter de se entregar aos excelentes estudos da Teologia) não obsta a que proponha diariamente algum problema de árdua, difícil e subtil resolução, e porque o tempo lhe não consente que se dedique às respectivas demonstrações geométricas, comete-me, por isso, essa tarefa. Nos últimos dias teve a curiosidade de saber a extensão dos crepúsculos nos diferentes climas. [...]. Nesta ordem de idéias, meditando e investigando, descobri coisas que em parte alguma li e não mereciam crédito, se não fossem demonstradas, a saber:” ⁽¹⁵⁾

Ora esta publicação acabou por ser uma das obras de mais alto nível científico escrita pelo salaciense, nela se resolvendo problemas de extremos (o do crepúsculo mínimo) por métodos geométricos bem engenhosos, problemas que só mais tarde (na segunda metade do século XVII ou já no século XVIII) viriam a ser considerados (por métodos análogos ou pelas novas técnicas do cálculo diferencial) por outros autores de renome — tais como os irmãos João e Jacob Bernouilli, L’Hospital e D’Alembert.

Além disso, seguindo Manuel Peres Jr. nos comentários que fez à obra, em 1943, “depois das obras de Albaténio e de Ibn Joenis nada se encontra na literatura astronómica da Idade Média que iguale ou se aproxime do *De Crepusculis*”; e ainda “Aplicando-lhe o simbolismo das fórmulas matemáticas, actualizando alguns têrmos e expressões [...] e reduzindo o excessivo rigor lógico pela supressão de algumas justificações desnecessárias, sem alterar a essência, a forma, o método e o objecto do livro, *De Crepusculis* appareceria transformado num livro moderno de Astronomia Esférica” [...] “Enfim, só por si *De Crepusculis* justifica a glorificação astronómica que a Pedro Nunes foi dada, atribuindo o seu nome a uma das crateras da Lua”. ⁽¹⁶⁾

Quanto ao célebre *nónio*, introduzido nesta obra para medir fracções de grau no astrolábio, e à sua discutida prioridade sobre o *vernier*, concorda Manuel Peres ⁽¹⁷⁾ que

(13) F.R. Dias Agudo, *Diário de Lisboa* de 18.11.67, p. 11

(14) Pedro Nunes, *Obra*, ed. A.C.L., Vol. III, p. 133 (tradução do latim)

(15) Pedro Nunes, *Obra*, ed. A.C.L., Vol. II, pp. 145-150

(16) *Idem*, p. 391

(17) Pedro Nunes, *Obra*, ed. A.C.L., Vol. II, p. 397

tão acertado é dizer que “il y a quelque analogie entre les principes des deux instruments” (como afirma o francês Maximilien Marie no Tomo II da sua *Histoire des Sciences Mathématiques et Physiques*, de 1883-1888, em 12 volumes) como dizer que não se devem confundir (opinião de Montucla no Tomo I da sua *Histoire des Mathématiques*, de 1799-1802, em 4 volumes).

A génese de *De Crepusculis* dá-nos mais uma lição, desta vez para os alunos:

Uma atitude não passiva perante o que se lhes ensina, um comportamento crítico perante o que estudam, a insatisfação perante algumas das explicações recebidas levam muitas vezes à criação de novos conhecimentos, em suma, ao progresso científico.

Pedro Nunes também fez traduções anotadas de obras importantes — como o *Tratado da Sphera*, de Sacrobosco, *Theorica do Sol e da Lua*, de Purbáquio e *Livro Primeiro da Geografia*, de Ptolomeu, traduções que vieram a ser publicadas em 1537 num volume que incluía ainda os seus dois primeiros tratados originais a que oportunamente nos referimos.

Escreveu (em latim, sem indicação de data) um resumo do *Tratado da Sphera* intitulado *Astronomici Introductorii de Sphera Epítome* e uma obra que ficara inédita e veio a ser publicada em 1952 por Joaquim de Carvalho sob o título *Defensão do Tratado da Rumasão do Globo para a Arte de Navegar*.⁽¹⁸⁾

A valiosa obra própria a que nos temos vindo a referir foi escrita por Pedro Nunes em português quando tinha objectivos pedagógicos e a destinava especialmente aos seus discípulos e em latim quando procurava que os resultados das suas investigações viessem a ter ampla divulgação pelos homens cultos de outros países que se interessassem pelos assuntos tratados (e com algum êxito, pois veio a ser citado, utilizado, apreciado por, entre outros, Clavius, Gosselin, Peletier, Stevin, Tycho Brahe e Vinet, ainda no século XVI, Dechales, Vossius, Wallis, no século XVII, Delambre e Kästner, no século XVIII).

Chegou a ser-lhe pedida uma opinião sobre a reforma do calendário juliano, que veio a ser promulgada pelo Papa Gregório XIII em 1582 (o jesuíta Christophoro Clavius, membro activo da comissão encarregada do estudo, frequentava em Coimbra o Colégio das Artes no tempo em que Pedro Nunes aí residia). Já velho e enfermo, não chegou a proceder a uma análise cuidada da proposta nem a dar parecer por escrito. Mas opinou verbalmente que a reforma lhe parecia inútil, por ser impossível eliminar os erros de todo o qualquer calendário.⁽¹⁹⁾

Alguns comentadores de Pedro Nunes parecem lamentar que não tenha defendido a teoria heliocêntrica, dada a conhecer por Copérnico na obra célebre *De revolutionibus orbium celestium*, publicada em 1543. Mas coloquemo-nos no seu tempo: outros homens de ciência de grande valor como Cardan (contemporâneo de Nunes, como temas acentuado), Vieta e Tycho Brahe (ligeiramente posteriores) não aceitaram o modelo copernicano porque, na altura, não lhe reconheciam vantagens sobre o ptolomaico quanto à concordância com as observações. E o nosso matemático foi, afinal, mais prudente, defendendo na sua publicação *De Arte atque ratione navigandi* que se deviam construir tábuas para os movimentos dos astros a partir de um modelo e outro para então se verificar

(18) Joaquim de Carvalho, *Obras Completas*, F. C. G., V pp. 341-374

(19) Idem, pp. 348-357

qual dos sistemas conduziria a resultados mais conformes com a realidade. E não esquecer que quando Kepler descobriu as suas leis e Galileo observou as quatro “luas” de Jupiter — factos decisivos para o esclarecimento da controvérsia — já Pedro Nunes havia falecido!

Deixámos para o fim o *Libro de Algebra en Arithmetica y Geometria* (publicado em castelhano em Anvers, em 1567, e que chegou a ser traduzido para latim e francês) por ser de características diferentes dos restantes trabalhos e aquele a que mais se referem os críticos quando classificam Pedro Nunes como matemático. ⁽²⁰⁾

Ao escrevê-lo, o autor não se contentou com o método expositivo-repetitivo que lera em Pacioli, apresentando demonstrações próprias e resolvendo muitos problemas com alguma generalidade (“mas este mesmo caso tratamos universalmente” escreve ele ao considerar de uma só vez o que outros autores tratavam caso a caso. ⁽²¹⁾)

Embora no seu tempo já se usasse uma álgebra sincopada, com alguns sinais e abreviaturas (e não meramente retórica, como a dos gregos e árabes) é certo que ficou longe (como, aliás, todos os seus contemporâneos) da revolução operada por Vieta quando, duas décadas mais tarde (na obra *In Artem Analyticam Isagoge*, de 1591) introduziu o simbolismo que fez dele o criador da álgebra moderna.

Mas como é o próprio Pedro Nunes que, na dedicatória ao Cardeal D. Henrique (seu antigo discípulo mas, agora, regente do reino), datada do 1º de Dezembro de 1564, e também num posfácio aos leitores, afirma “Esta obra ha perto de XXX anos que foy per my cõposta (em nossa lingua Portuguesa, & assi a uio V.A.; [...]); e auiendola ya comunicado a muchos); mas porque despois fuy occupado em estudo de cousas muy diferentes & de mera especulação, posto que algũas vezes a reuisse, & conferisse com o q̄ outros despois escreuerão, e deixey de publicar ategora”, ⁽²²⁾ fica-se na dúvida se, com as capacidades que revelou em tudo o que fez, Pedro Nunes não teria ido mais longe nos seus estudos de álgebra, não fosse ele obrigado a tarefas oficiais tão dispersivas, dispusesse ele de mais tempo para as reflexões tão necessárias aos grandes saltos qualitativos.

Sujeito embora a algumas criticas desfavoráveis (a rejeição de soluções negativas das equações, no que, no entanto, estava acompanhado por Stiefel e Vieta, e sobretudo, a descrença na utilidade das fórmulas de Tartaglia para a resolução das equações do terceiro grau), dele afirmou o belga Padre Bosmans, em apreciações que fez ao *Libro de Álgebra* em 1907 e 1908:

i) Em Bosmans, 1907-1908, p. 165: “la lecture de Nuñez a probablement suggeré à Stevin l’idée de rechercher une méthode générale pour déterminer le plus grand commun diviseur de deux polynomes...” (a propósito do facto de Pedro Nunes procurar resolver a cúbica pelo que hoje chamamos abaixamento de grau).

(20) Segundo a obra citada na Nota 5, p. 179, dizia Rey Pastor de Pedro Nunes que “no hay que olvidar que la matemática no era el objeto principal de sus investigaciones, las cuales estaban centradas sobre la Cosmografía y el Arte de la Navegación, pero aun siendo así enriqueció la matemática com varias ideas verdaderamente geniales, que lo colocan a una altura inmensa sobre los demás matemáticos españoles y portugueses y quizás de todos los tiempos.”

(21) Pedro Nunes, *Obra*, Ed. A.C.L., vol. VI, pp. 397-398

(22) Idem, pp. XIII-XIV e 393

ii) Em Bosmanns, 1908: “ses demonstrations sont originales et très remarquables” (p. 233); [...] “Considéré dans son ensemble ce chapitre de Nuñez ⁽²³⁾ n’a d’analogie, chez aucun contemporain. Nuñez à un certain point de vue surpasse tous ses émules, même les plus illustres, même les Cardan et les Stiefel. Du premier au dernier sans une exception, les problèmes du chapitre 5 sont des exercices abstraits sur les nombres” (pp. 245-246).

Sobre um dos exercícios (nº 81), comenta Bosmanns: “Nous sommes au XVIème siècle, ne l’oublion pas, et ce raisonnement est donné comme général et s’appliquant à tous les cas. Je mets au défi de trouver un sujet analogue traité avec plus d’élégance par Cardan ou par Stiefel!” (p. 260). E prossegue: “Viète a donc eu des précurseurs. Nuñez fut l’un des principaux. Aucun contemporain ne le surpasse en rigueur [...]. Parmi les grands mathématiciens qui séparent Stiefel et Cardan de Viète, il brille au tout premier rang. C’est l’une des gloires du Portugal”. (pp. 270-271).

E podemos, de facto, orgulhar-nos de ter sido Pedro Nunes um dos que mais contribuíram para criar o ambiente que proporcionou a Vieta o grande salto em frente que foi a criação da álgebra simbólica, a álgebra dos nossos dias.

Bibliografia

- Albuquerque, Luis de, 1963, “Ciência Náutica Portuguesa” in *Dicionário de História de Portugal* dirigido por Joel Serrão.
1971, “A projecção da náutica portuguesa quinhentista na Europa”, *Memórias A. C. L.*, XV.
1972, “Sobre as prioridades de Pedro Nunes”, *Idem*, XVI.
1976-1977, “Pedro Nunes e Diogo de Sá”, *Idem*, XXI.
1987, *As navegações e a sua projecção na ciência e na cultura*, Gradiva.
- Almeida, A.A. Marques de, 1986, “A aritmética comercial em Portugal nos séculos XVI e XVII” in *História e Desenvolvimento da Ciência em Portugal*, A.C.L.
- Bosmanns, H., S.J., 1907-1908, Sur le “Libro de algebra” de Pedro Nuñez, *Bibliotheca Mathematica*, 3ª ser., t. 8, Leipzig.
1908, L’Algèbre de Pedro Nunez, *An. Sc. Acad. Pol. Porto*, vol. 3
- Carvalho, Joaquim de, *Obras Completas*, Ed. Fundação C. Gulbenkian (1978-).
- Cortês, Armando, 1960, *A Cartografia Portuguesa Antiga*, Coleção Henriquina.
- Costa, A. Fontoura da, 1960, *A Ciência Náutica Portuguesa*, Coleção Henriquina.
- Cunha, Pedro José da, 1941, “As matemáticas em Portugal no século XVII”, *Memórias A.C.L.*, III
- Dias-Agudo, F.R., 1967, *Diário de Lisboa de 18.11.67*, p. 11.
1985, Os portugueses e a matemática: de Pedro Nunes a Gomes Teixeira, passando pela decadência: contribuição da A.C.L. para o ressurgimento”, *Congresso Os Portugueses e o Mundo*, Porto.
1986, “Contribuição da A.C.L. para o desenvolvimento da Ciência”, *História e Desenvolvimento da Ciência em Portugal*, A.C.L.
1988, “A Matemática em Portugal”, *ICALP* nºs 12-13.
1993, “Ambiente sócio-cultural e criação matemática” in *A Universidade e os Descobrimientos*, Comissão Nacional para as Comemorações dos Descobrimientos Portugueses, INCM.
1995, “Matemática: Bela ou Monstro?” in *Matemática e Cultura II*, Centro Nacional de Cultura.
- Ferreira Deusdado, *Educadores Portugueses*, ed. Lello & Irmão, Porto (1995)
- Gonçalves, J. Vicente, 1984-1985, “Passos de Pedro Nunes ao serviço do Rei”, *Memórias A.C.L.*, XXVI.

(23) Cap. 5 da 3ª parte principal

- Kline, Morris, 1972, *Mathematical thought from ancient to modern times*, Oxford Un. Press.
 1990, *Mathematics in western culture*, Penguin Books.
- Mota, A. Teixeira da, 1969, "Os regimentos do cosmógrafo-mor de 1559 e 1592 e as origens do ensino náutico em Portugal", *Memórias A.C.L.*, XIII
- Nunes, Pedro, *Obras*, edição da A.C.L. (1940 e anos seguintes), incluindo comentários de P.J. Cunha, M. Peres Jr., Joaquim de Carvalho e V. Hugo de Lemos
 Vol. I — *Tratado da Sphaera & Astronomici Introductorii de Spaera Epitome*
 Vol. II — *De Crepusculis*
 Vol. III — *De Erratio Orontii Finaei Mathematicarvm Lvtetiae Professoris*
 Vol. VI — *Libro de Algebra en Arithmetica y Geometria* (não publicados os volumes IV e V).
- Reis, Manuel dos, 1976, "No quinto centenário de Copérnico", *Memórias A.C.L.*, XIX.
- Sá, A. Moreira de, 1960, *O Infante D. Henrique e a Universidade*, Coleção Henriquina.
- Scott, J.F., 1958, *A history of mathematics*, London.
- Sisto Rios e outros, 1979, *Julio Rey Pastor matemático*, Instituto de España.
- Smith, D.E., 1951, *History of mathematics*, 2 vol., Dover.
- Struik, D.J., 1989, *História concisa das matemáticas*, Gradiva
- Teixeira, F. Gomes, 1925, "Elogio histórico de Pedro Nunes", *Panegíricos e Conferências*, A.C.L.
- Tiago de Oliveira, J., 1981-1982, "A produção matemática portuguesa no século XIX; comparação com o século XVI", *Memórias A.C.L.*, XXIV.
 1989, *O essencial sobre a história das matemáticas em Portugal*, INCM
 1991, *As matemáticas no Portugal de Quinhentos*, Conferência na Universidade do Minho.

*introductory lectures
conférences introductives
conferências introdutórias*

The lecturers were invited by the Programme Committee. The duration of the introductory lectures is 45 min.. Lectures given at the meeting but not included in these proceedings are listed at the end of this volume.

Les conférenciers ont été invités par le Comité du Programme. La durée de ces conférences est de 45 min.. Vous trouverez dans les dernières pages de ce volume les titres des conférences présentées a la rencontre mais qui ne sont pas incluses dans ces actes.

Os conferencistas foram convidados pela Comissão do Programa. As conferências introdutória têm a duração de 45 min.. Nas últimas páginas deste livro encontrará os títulos e autores das conferências que não constam das actas.

SOBRE MATEMÁTICA NA HISTÓRIA DA ÁFRICA SUB-SAHARIANA

Paulus Gerdes, Universidade Pedagógica, Moçambique

No estudo clássico "África Conta: número e padrão em cultura africana",¹ Claudia Zaslavsky apresentou um panorama geral da literatura disponível sobre a história da matemática na África sub-Sahariana. Ela analisou contagem escrita, falada e por gestos, misticismo numérico, conceitos de tempo, números e dinheiro, pesos e medidas, registo e arquivo (estacas e fios), jogos matemáticos, 'quadrados mágicos', grafos, forma geométrica, e Crowe contribuiu com um capítulo sobre simetrias geométricas na arte africana. Desde a publicação do livro de Zaslavsky muitos estudiosos, estudantes e professores — tanto dentro como fora de África — ficaram interessados na herança matemática da África sub-Sahariana. A União Africana de Matemática (sigla em inglês: AMU) formou, em 1986, a Comissão da AMU para a História da Matemática em África (sigla em inglês: AMUCHMA). Para estimular a investigação sobre a história da matemática em África em geral, e para promover a divulgação dos resultados da investigação e a troca de informações neste campo, a AMUCHMA publica, desde 1987, um Boletim Informativo em inglês, francês e árabe.² Neste texto apresenta-se um panorama geral da investigação, concluída ou em curso, sobre a história da matemática na África sub-Sahariana.³ Breves informações sobre tópicos como sistemas de contagem e de numeração, numerologia, jogos e adivinhas matemáticas, geometria, e grafos serão incluídos. Também se dão alguns exemplos de utilização de elementos matemáticos da herança africana sub-Sahariana na educação matemática.

Para que estudar/investigar a história da matemática na África sub-Sahariana?

Há muitas razões para tornar o estudo geral da história da matemática tanto necessário como atractivo. Existem razões adicionais importantes para tornar a investigação da história da matemática na África sub-Sahariana indispensável.

Países africanos vêem-se confrontados com 'níveis baixos' de aproveitamento em matemática. O medo pela matemática é um fenómeno bem conhecido. Muitas crianças (e professores também) experimentam a matemática como uma disciplina bastante estranha e inútil, importada de fora de África. Uma das causas para este fenómeno reside no facto de que os objectivos, conteúdos e métodos da educação matemática não são adaptados (ou não o são suficientemente) às culturas e

1. C.Zaslavsky, *Africa Counts: number and pattern in African culture*, Prindle, Weber and Schmidt, Boston, 328 p.(nova edição: Lawrence Hill, Brooklyn, NY, 1979); tradução húngara: *Africa Szamol*, Gondalet, Budapest, 1984; tradução francesa: *L'Afrique compte! Nombres, formes et démarches dans la culture africaine*, Éditions du Choix, Argenteuil, 1995, 328 p.

2. O Boletim Informativo da AMUCHMA pode ser solicitado na versão inglesa ao Presidente Paulus Gerdes (C.P. 915, Maputo, Moçambique) e nas versões francesa e árabe, ao Secretário Ahmed Djebbar (Département de Mathématiques, Université Paris-Sud, 91405 Orsay Cedex, França) da AMUCHMA respectivamente.

3. Para uma bibliografia sobre a história da matemática na África sub-Sahariana, vide P. Gerdes, Sobre a História da Matemática na África ao Sul do Sahara, *AMUCHMA, Revista sobre a História da Matemática em África*, Nº 1, Maputo, 1992, 5-36, e uma versão mais actualizada em Inglês: P.Gerdes, On mathematics in the history of subsaharan Africa, *Historia Mathematica*, New York, Vol.21, 1994, 345-376.

necessidades dos povos africanos. Vários analistas são da opinião de que a herança matemática dos povos de África devia ser valorizada através da sua integração no curriculum. Também vários representantes das minorias de descendência africana noutros continentes salientam a necessidade de conhecer a herança matemático-cultural africana. E, em geral, tanto nos países altamente industrializados como nos países do chamado Terceiro Mundo, reconhece-se, cada vez mais, que é necessário *multi-culturalizar* o curriculum da matemática tanto para poder combater preconceitos raciais e culturais como para poder aumentar a autoconfiança de todos os alunos.

Concepção lata de 'história' e 'matemática'

A maioria dos livros da história da matemática dedicam apenas umas poucas páginas ao Egipto Antigo e à África do Norte durante a 'Idade Média'. Em geral, ignoram a história da matemática na África sub-Sahariana e dão a impressão de que essa história ou não existiu, ou, pelo menos, não é cognoscível, ou, ainda mais grave, dão a impressão de que nunca houve matemática ao Sul da Sahara. Até a africanidade da matemática egípcia é amiúde negada. Preconceitos e concepções estreitas tanto de 'história' como de 'matemática' formam a base desses pontos de vista (eurocêntricos).

Qualquer definição estreita de ciência em termos modernos tornaria difícil para compreendermos as suas origens e as formas mais variadas que assumiu em culturas diferentes. Numa concepção lata, a matemática é considerada como um fenómeno pan-cultural, incluindo contar, localizar, medir, desenhar, jogar, explicar, classificar, distribuir...⁴

É a etnomatemática, como disciplina, que estuda a matemática (e a educação matemática) enquadrada no seu contexto cultural.⁵ A aplicação de métodos de investigação históricos e etnomatemáticos contribuiu, como mostraremos, para o maior conhecimento e compreensão da matemática na história de África, ou, pelo menos, com mais alguns elementos matemáticos em tradições africanas, em suplemento à informação recolhida em "África Conta".

Muitas ideias e actividades matemáticas em culturas africanas não são explicitamente 'matemáticas'. São frequentemente 'entretecidas' com arte, artesanato, adivinhas, jogos, e outras tradições. Alguns estudos dedicaram-se à metodologia de como se pode desvendar esse conhecimento implícito. Um dos métodos pode ser caracterizado da seguinte maneira: ao analisar as formas geométricas de objectos tradicionais — tais como de cestos, esteiras, potes, casas, armadilhas de caça e de pesca — o investigador interroga-se por que razão é que os produtos materiais possuem a forma que têm. Para responder a esta questão, o pesquisador aprende as técnicas de produção usuais e tenta, em cada fase do processo de produção, variar as formas. Ao fazê-lo, ele observa que a forma representa, geralmente, muitas vantagens práticas e é, na maior parte das vezes, a solução única ou óptima dum problema de produção. Aplicando o método, tornou-

⁴ Vide, por exemplo, A. Bishop, *Mathematical enculturation, a cultural perspective on mathematics education*, Kluwer, Dordrecht, 1988, 195 p.

⁵ Para uma análise da origem e desenvolvimento da etnomatemática, inclusive da sua relação com a educação matemática, vide P. Gerdes, *Ethnomathematics and mathematics education: an overview*, in: A. Bishop (org.), *International Handbook on Mathematics Education*, Kluwer, Dordrecht, 1996 (no prelo).

se possível desvendar conhecimentos sobre as propriedades de circunferências, ângulos, rectângulos, quadrados, pentágonos e hexágonos regulares, cones, pirâmides, cilindros, simetria, etc., que estavam provavelmente envolvidos na invenção das técnicas de produção consideradas. ⁶

Uma vez que a história da matemática em África não pode ser considerada nem isoladamente do desenvolvimento da cultura em geral, nem dissociada da evolução da arte, da cosmologia, da filosofia, das ciências naturais, da medicina, da linguística, dos sistemas gráficos e da tecnologia em particular, o estudo da matemática na África sub-Sahariana exige uma interdisciplinaridade, devendo sempre ter em conta os resultados de investigação de outras disciplinas. Os estudos sobre as interações múltiplas e variadas entre as línguas africanas e a aprendizagem da matemática apresentam dados importantes sobre ideias matemáticas em culturas africanas. ⁷ Desde o estudo clássico de Gay & Gole sobre a aprendizagem da matemática e as capacidades matemáticas no seio dos Kpelle da Libéria, ⁸ psicólogos realizaram vários estudos sobre capacidades e conhecimentos matemáticos por parte de grupos de crianças e grupos profissionais (por exemplo, costureiros e comerciantes não-escolarizados na Costa do Marfim), ⁹ sobre a compreensão de relações espaciais, a reprodução de simetria e de padrões.

Elementos mais antigos

Zaslavsky apresentou um osso datado de 9000 a 6500 a.C., desenterrado em Ishango (Zaire) como a mais antiga evidência de actividade matemática em África. O osso tem o que parecem ser marcas de contagem, uma série de cortes entalhados em grupo. Mais tarde, a data do osso de Ishango foi reavaliada, passando de aproximadamente 8000 a.C. para 20.000 a.C.

Bogoshi et al. relatam, em 1987, a existência dum "artefacto matemático" ainda mais antigo: "Um pedaço pequeno do peróneo de um babuíno, marcado com 29 entalhes claramente definidos, pode ser classificado como o mais antigo artefacto matemático conhecido. Descoberto no início dos anos 70 durante uma escavação na Cave Fronteira nas Montanhas Libombo entre a África do Sul e a Suazilândia, o osso foi datado de aproximadamente 35.000 a.C." ¹⁰

Um projecto de investigação analisando representações numéricas na arte rupestre dos San, foi iniciado pela Universidade de Witwatersrand (África do Sul). Investigadores da Universidade de Botswana recolheram informação dos caçadores San sobreviventes no Botswana, descrevendo a contagem, medição, o cálculo do

⁶ Vide: P.Gerdes, *Sobre o despertar do pensamento geométrico*, Universidade Federal de Paraná, Curitiba, 1992, 105 p.; *Cultura e o despertar do pensamento geométrico*, ISP, Maputo, 1991, 146 p.; *Ethnogeometrie. Kulturanthropologische Beitrage zur Genese und Didaktik der Geometrie*, Verlag Barbara Franzbecker, Bad Salzdetfurth, 1991, 347 p.

⁷ Vide, por exemplo, os relatórios dos seminários organizados pela CASME (Languages and the teaching of science and mathematics with special reference to Africa, Accra, 1975), pela UNESCO (Interactions between linguistics and mathematical education', Paris, 1975) e pelo IREM (Mathématique, langues africaines et français, Niamey, 1977).

⁸ J.Gay & M.Cole, *The new mathematics and an old culture, a study of learning among the Kpelle of Liberia*, Holt, Rinehart & Winston, Nova Iorque, 1967, 100 p.

⁹ Vide por exemplo :A.Petitto, *Knowledge of arithmetic among schooled and unschooled tailors and cloth merchants in Ivory Coast*, tese de doutoramento, Universidade Cornell, Ithaca, 1978.

¹⁰ J.Bogoshi, K.Naidoo & J.Webb, *The oldest mathematical artefact*, *The Mathematical Gazette*, Londres, 1988, Vol.71, 294

tempo, a classificação, a localização e algumas ideias matemáticas na tecnologia e no artesanato San. Os San desenvolveram uma discriminação visual e uma memória visual muito boas, necessárias para a sobrevivência no meio ambiente árido do deserto Kalahari.¹¹

Sistemas de numeração

Desde a publicação do livro de Zaslavsky, toda uma série de projectos de investigação sobre sistemas de numeração falada em África teve o seu início, por exemplo, sobre os métodos de contagem e sistemas de numeração no seio de várias etnias da Nigéria (Ibibio, Efik, Fulani, ...), no Burundi, na Costa de Marfim, na Guiné, em Moçambique,¹² no Quênia e no Senegal. Nos sistemas falados de numeração as bases mais utilizadas são 10, 5 e 20. Por exemplo, a língua Macua (do Norte de Moçambique) tem um sistema misto de bases 5 e 10; a língua Bété da Costa de Marfim usa três bases: 5, 10 e 20; os Yoruba da Nigéria têm um sistema vigesimal e os Bambara do Mali um decimal-vigesimal.

Vários estudos debruçam-se sobre sistemas de numeração escrita. A título de exemplo, entre os Fulani, um povo semi-nómada do Niger e do Norte da Nigéria, colocam-se estacas em frente das casas para indicar o número de vacas ou cabritos que possuem. Uma centena de animais é representada por duas estacas curtas colocadas no chão formando um V. Duas estacas que se cruzam, X, simbolizam cinquenta animais. Quatro estacas numa posição 'vertical', IIII, representam quatro; duas estacas numa posição 'horizontal' indicam vinte animais. A configuração VVVVVXII em frente de uma casa mostra que o dono possui 652 vacas.¹³

Os povos Akan (Costa de Marfim, Ghana, Togo) usavam pesos monetários, isto é, usavam estatuetas como moedas. Estava combinado que o peso de uma estatueta representava o valor monetário correspondente a uma certa quantia de ouro em pó do mesmo peso. As estatuetas representam animais, nós, cadeiras, sandálias, tambores, etc., e podem também ter diversas formas geométricas tais como pirâmides, estrelas ou cubos. Em muitos pesos monetários apresentam-se sinais gráficos que representam números (vide Figura 1). Embora se utilize apenas a base "dez" nas línguas faladas pelos povos Akan, a base "cinco" encontra-se igualmente nos pesos monetários. É interessante notar que os Agni, um dos grupos populacionais Akan, usaram uma série de unidades de pesos monetários com uma estrutura binária: cada unidade nova é o dobro da unidade anterior.

11 Compare L.Liebenberg, *The art of tracking — The origin of science*, David Philip Publishers, Cidade de Cabo, 1990, 176 p.

12 Vide P.Gerdes (org.), *A numeração em Moçambique — Contribuição para uma Reflexão sobre Cultura, Língua e Educação Matemática*, ISP, Maputo, 1993, 159 p. Este livro inclui informações gerais sobre sistemas de numeração em África, dados sobre métodos populares de contagem e sobre a numeração em Moçambique, e uma análise da numeração falada como recurso na aprendizagem da Aritmética.

13 Vide S.Ale, *Mathematics in rural societies*, in: C.Keitel, P.Damerow, A.Bishop, P.Gerdes (org.), *Mathematics, Education, and Society*, UNESCO, Paris, 1989, 35-38. Ale analisa as possibilidades de construir um curriculum que toma como ponto de partida a herança cultural e que satisfaz as necessidades do povo Fulani (Fulbe).

1					
2		∩	∪		
3		∩	ε		
4		—	3		∂
5		卐	○		6
6		⚡		⬡	6
7		▽	/		6c
8			×	⬢	6e
9		卐	\		6-
10		卐	+		
11			30E	□	
12		⚡			
13		⚡			-6-
14		▽			
15		卐卐卐	⊞		
20		卐			

Exemplos de numerais em pesos monetários dos povos Akan ¹⁴
 Figura 1

Simbolismo numérico

"África Conta" dedica um capítulo a simbolismo numérico e tabus de contagem (52-57). Mfika analisou o significado de números na cosmogonia Luba (Zaire), por exemplo, dos números pares e ímpares, e dos 'números da paz': 4 e 12, 24, 48, 96. ¹⁵ Recentes são os estudos que mostram que simbolismo numérico pode ter uma base racional. Por exemplo, cesteiros Macua do Norte de Moçambique chamam 'feios' a números ou quantidades ímpares de tiras de planta, e 'bonitos' a quantidades pares, tendo eles boas razões para o fazer. ¹⁶

¹⁴ Compilado com base em dados fornecidos em N. Niangoran-Bouah, *L'univers Akan des poids a peser*, Vol. 1, *Les poids non figuratifs*, Les Nouvelles Éditions Africaines, Abidjan, 1984, p.253, e R.Mveng, *L'art et l'artisanat africains*, Éditions Clé, Yaoundé, 1980, p.33.

¹⁵ Vide: M.Mfika, *Sur le sentier mystérieux des nombres noirs*, L'Harmattan, Paris, 1988, 187 p.

¹⁶ Vide: A.Ismael, On the origin of the concepts of "even" and "odd" in Makhuwa culture, in: P.Gerdes (org.), *Explorations in Ethnomathematics and Ethnoscience in Mozambique*, ISP, Maputo, 1994, 9-15.

Adivinhas

Bem conhecidas de várias partes de África (Etiópia, Libéria, Tanzânia, ...) são variantes da adivinha sobre um homem que tem um leopardo, uma cabrita, e um monte de folhas de mandioca a serem transportados sobre um rio. As seguintes condições (ou outras) têm de ser satisfeitas: o barco não pode levar mais do que um, ao mesmo tempo, além do próprio homem; a cabrita não pode ser deixada sozinha com o leopardo, e a cabrita comerá as folhas de mandioca se não se toma conta dela. Como é que o homem pode transportá-los sobre o rio? Mais difícil para resolver é uma 'adivinha aritmética' dos (Va)luchazi (Angola oriental e noroeste da Zâmbia), gravada e analisada por Kubik (1990, 62): Esta 'história de dilema' é sobre três mulheres e três homens que pretendem passar um rio para participar numa festa do outro lado do rio. Há somente um barco com capacidade de levar apenas duas pessoas ao mesmo tempo. No entanto, cada homem gostaria de casar, ele próprio, com as três mulheres. No que diz respeito à passagem, gostariam de passar o rio em pares, cada homem com a sua parceira, mas evitando que qualquer um dos outros homens possa reclamar todas as três mulheres para ele sozinho. Como devem passar o rio?" Para resolver o problema ou para explicar a solução, os (Va)luchazi traçam desenhos auxiliares no chão.

Arte e simetrias

O matemático camaronês Njock caracteriza a relação entre a arte africana e a matemática da seguinte maneira: "Matemática pura é a arte de criar e de imaginar. Neste sentido, arte negra é matemática".¹⁷



Banda ornamentada numa pasta entrelaçada (Inhambane, Moçambique)

Figura 2

Simetrias na arte africana — padrões decorativos que aparecem em tecidos de ráfia dos Bakuba (Zaire), em objectos de bronze do Benin, em tecidos 'adire' dos Yoruba (Nigéria), em tecidos 'adinkra' (Ghana), em pipas de Begho (Ghana), em pastas entrelaçadas dos Gitonga (Moçambique), etc. — foram analisadas por vários matemáticos (vide, por exemplo, Crowe, Wasburn, Gerdes e Bulafo).¹⁸ Algumas

¹⁷ Vide G.Njock, *Mathématiques et environnement socio-culturel en Afrique Noire, Présence Africaine*, 1985, n° 135, 3-21 (citação p.8)

¹⁸ Vide: D.Crowe, Geometric symmetries in African art, in: Zaslavsky, 1973 o.c., 190-196; The geometry of African art II. A catalog of Benin patterns, *Historia Mathematica*, Nova Iorque, 1995, Vol.2, 253-271; The geometry of African art III. The smoking pipes of Begho, in: C.Davis, B.Grunbaum, F.Sherk (org.), *The geometric vein, the Coxeter Festschrift*, Springer

razões pela aparência de alguns tipos de simetria (axial, duplamente axial, quádrupla e quádrupla) em cestaria africana foram desvendados por Gerdes. ¹⁹ Conhecimentos matemáticos incorporados no artesanato feminino são analisados no livro "Mulheres e Geometria na África Austral." ²⁰

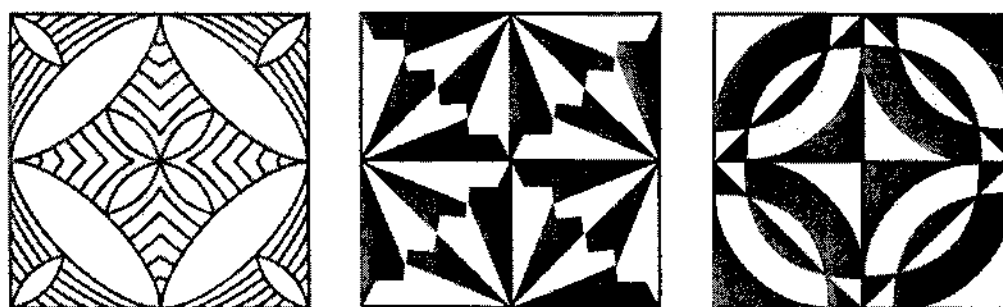

Exemplos de padrões geométricos com os quais mulheres costumavam de ornamentar as paredes das suas casas (Lesotho)

Figura 3

Exemplos diversos de utilização de simetrias da arte africana no ensino de matemática são apresentados por Harris (tecidos 'adinkra', cestos do Botswana, camisas 'buba' dos Yoruba), e Stott e Lea (pintura mural, cestaria, cerâmica, estilos de cabelo trançado, etc. no Botswana). ²¹ No livro "Pitágoras Africano" mostra-se como diversos ornamentos e artefactos simétricos podem ser usados para criar um contexto atraente para a descoberta e demonstração do Teorema de Pitágoras e de ideias e proposições com ele relacionadas. ²²

Jogos

De entre todas as tradições sub-Saharianas, os jogos com 'ingredientes' matemáticos atraíram, sem dúvida, a maior atenção dos matemáticos e educadores. Zaslavsky (o.c., 102-136) analisa rimas e ritmos de contagem, jogos-de-três-numa-fila, ²³ arranjos, jogos de azar e jogos de tábua. Jogos do tipo de 'mancala',

-
- Verlag, Nova Iorque, 1982, 177-189; Symmetry in African art, *Ba Shira, Journal of African Languages and Literature*, 1982, Vol.3, Nº.1, 57-71; D.Washburn & D.Crowe, *Symmetries of Culture, Theory and Practice of Plane Pattern Analysis*, University of Washington Press, Washington, 1988, 312 p.; P.Gerdes & G.Bulafo, *Sipatsi: Tecnologia, Arte e Geometria em Inhambane*, ISP, Maputo, 1994, 102 p.
- 19 Vide, por exemplo, P.Gerdes, *Sobre o despertar do pensamento geométrico*, Universidade Federal de Paraná, Curitiba, 1992, 105 p.; *Cultura e o despertar do pensamento geométrico*, ISP, Maputo, 1991, 146 p.; e Fivefold Symmetry and (basket)weaving in various cultures, in: I.Hargittai (org.), *Fivefold symmetry in a cultural context*, World Scientific Publishing, Singapore, 1991, 243-259.
- 20 P.Gerdes, *Women and Geometry in Southern Africa*, Universidade Pedagógica, Maputo, 1995, 200 p.; *Femmes et Géométrie en Afrique Australe*, L'Harmattan, Paris, 1996, 219 p.
- 21 M. Harris, *Cabbage, Mathematics in Work*, University of London Institute of Education, 1988; L.Stott & H.Lea, *Common threads in Botswana*, British Council, Gaberone, 1993, 82 p.
- 22 P.Gerdes, *Pitágoras Africano: Um estudo em cultura e educação matemática*, ISP, Maputo, 1992, 102 p. (em inglês, 1994)
- 23 Vide também: C.Zaslavsky, *Tic Tac Toe and other three-in-a-row games, from Ancient Egypt to the modern computer*, Harper & Row, Nova Iorque, 1982

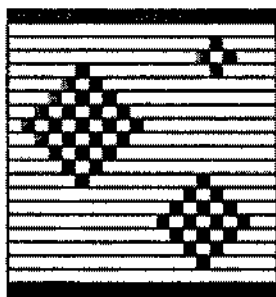

(Ovimbundu, Angola)

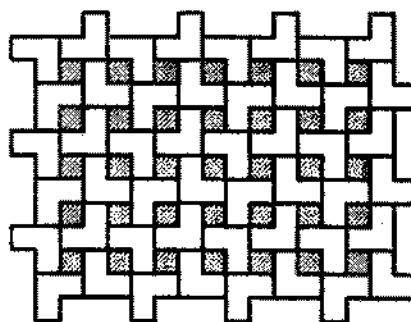

(Bakuba, Zaire)

Exemplos de padrões ornamentais 'pitagorizáveis'

Figura 4

conhecidos pelos nomes de Ayo, Bao, Wari, Mweso, Ntchuba, etc., foram analisados em diversas publicações: "Omweso: um jogo praticado no Uganda", "Jogos estratégicos nos Camarões e os seus aspectos matemáticos", "Wari e Solo, o jogo africano de cálculo", "Regras e estratégias do jogo Awélé", "Estratégias dos jogadores de Awélé", "Awélé, o jogo das semestres africanas", "Owani e Songa: dois jogos africanos de cálculo"[Congo, Camarões, Gabão, Guiné Equatorial] e "Jogos africanos de estratégia".²⁴

D.Mosimege (África do Sul) e A.Ismael (Moçambique) experimentam com a utilização de jogos tradicionais africanos na aula de matemática: jogos de barbante e Ntchuba e Murarava, respectivamente. A equipa de investigação coordenada por S.Doumbia (Costa do Marfim), dedica-se ao estudo de jogos africanos, classificando-os, resolvendo problemas matemáticos postos pelos jogos e analisando possibilidades de usá-los na aula de matemática. Descobriu-se que as regras de alguns jogos, como Nigbé Alladian (um jogo de conchas), revelam um conhecimento tradicional, pelo menos empírico, de probabilidades.²⁵ O seu Instituto de Investigação Matemática de Abidjan em conjunto com o Centro de Ciências de Orléans (França) organizou uma exposição ambulante sobre "Jogos Africanos, Matemática e Sociedades", inaugurada em 1994.²⁶

²⁴ M.Nsimbi, *Omweso: a game people play in Uganda*, African Studies Center, Los Angeles, 1968, Occasional Paper, Nº 6; M.Mizone, Les jeux stratégiques camerounais et leurs aspects mathématiques, *Annales de la Faculté des Sciences du Cameroun*, 1971, Nº 6, 19-38; A.Deledicq & A.Popova, *Wari et Solo. Le jeu de calcul africain*, Cedec, Paris, 1977, 206 p.; K.Ballou, *Règles et stratégies du jeu d'awélé*, Nouvelles Éditions Africaines, Abidjan, 1978, 55 p.; J.Retschitzki, *Stratégies des Joueurs d'Awélé*, L'Harmattan, Paris, 1990, 240 p.; P.Reyssset & F.Pingaud, *Awélé: Le jeu des semailles africaines*, Chiron-Algo, Paris, 1995, 109 p.; B.Mve-Ondo, *L'Owani et le Songa: Deux jeux de calculs africains*, Sépia, Paris, 1990, 133 p.; L.Crane, *African games of strategy, a teaching manual*, African Outreach Series (University of Illinois), 1982, Nº 2, 53 p. Vide também: W.Driedger, The game of Bao or Mankala in East Africa, *Mila*, 1972 Vol.3, Nº 1, 7-17 (University of Nairobi); R. Pankhurst, Gabata and related board games of Ethiopia and the Horn of Africa, *Ethiopia Observer*, 1991, Vol.14, Nº 3, 154-206; A.N'Guessan, L'awélé - acquisition des tactiques et des stratégies, in: R.Bureau, & D.Saivre (org.), *Apprentissage et cultures, les manières d'apprendre*, Éditions Karthala, Paris, 1988, 230-244.

²⁵ S.Doumbia & J.Pil, *Les jeux de cauris*, Ceda-IRMA, Abidjan, 1992, 73 p.

²⁶ Um número especial (69, Dez. 1994) da revista francesa de educação matemática PLOT é dedicado a esta exposição (PLOT APMEP, Université, BP 6759, 45067 Orléans-Cédex 2). Endereço da coordenadora: S.Doumbia, IRMA, Université Nationale du Côte d'Ivoire, 08 BP 2030, Abidjan 08, Côte d'Ivoire (Fax: 225-448397).

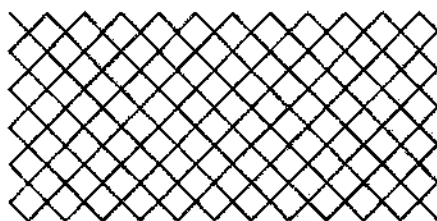

Exemplo dum desenho Bushongo composto por uma única linha
Figura 5

Sona — desenhos na areia

Uma pequena secção do livro "África Conta" (p. 105-109) é dedicada a alguns desenhos feitos na areia por rapazes Bushongo (Zaire) [vide o exemplo na Figura 5].²⁷ Mais tarde a informação etnográfica²⁸ sobre os desenhos na areia, chamados sona (sing. lusona), no Nordeste de Angola e Noroeste de Zâmbia atraíu a atenção de matemáticos. Para facilitar a memorização dos seus desenhos estandardizados, os especialistas de desenho utilizaram a seguinte mnemónica: depois de limparem e alisarem o chão, marcam, primeiramente, com as pontas dos dedos uma rede ortogonal de pontos equidistantes; em seguida são traçadas uma ou mais linhas que 'abraçam' os pontos da rede de referência (vide a Figura 6).

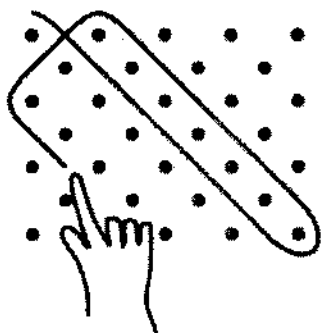

Execução dum lusona
Figura 6

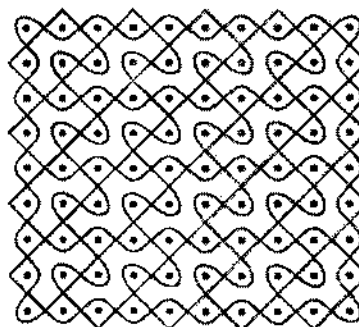

Dois sona construídos aplicando o mesmo algoritmo geométrico
Figura 7

- 27 Algumas possibilidades de utilização destes desenhos na aula de matemática são apresentadas em: A. Whitcombe & M. Donaldson, Shongo networks, a multicultural theme for the classroom, *Mathematics in School* (Grã Bretanha), Novembro 1988, 34-38; e em: C. Zaslavsky, *The multicultural math classroom*, Heinemann, Portsmouth, 1996, 195-197.
- 28 Em particular, dois estudos publicados em Português: E. dos Santos, Contribuição para o estudo das pictografias e ideogramas dos Quiocos, *Estudos sobre a Etnologia do Ultramar Português*, Lisboa, 1961, Vol.2, 17-131 e M. Fontinha, *Desenhos na areia dos Quiocos do Nordeste de Angola*, Instituto de Investigação Científica Tropical, Lisboa, 1983, 304 p., referente a desenhos recolhidos, durante os anos 40 e 50, no seio dos Tchokwe do Nordeste de Angola.

Aplicando o seu método, os especialistas de desenho reduzem a memorização de toda uma figura à de alguns números (as dimensões da rede de referência) e de um algoritmo geométrico [a regra de como traçar a(s) linha(s)]. Os desenhos referem-se a provérbios, fábulas, jogos, adivinhas, animais, etc. e desempenham um papel importante na transmissão do conhecimento e da sabedoria de uma geração para a seguinte.

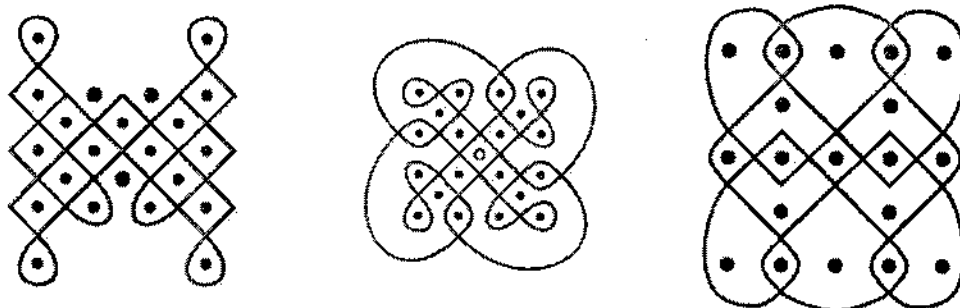

Exemplos de sona simétricos e monolineares
Figura 8

Ascher e Gerdes conduziram, independentemente um do outro, investigações sobre os 'sona'. M.Ascher estudou alguns aspectos geométricos e topológicos dos sona, em particular de simetrias, extensão, ampliação por repetição, e isomorfia.²⁹ Com os livros "Geometria Sona", Gerdes contribuiu para a reconstrução do saber matemático dos inventores dos sona.³⁰ Analisa simetria e monolinearidade (quer dizer, toda a figura é composta por apenas uma única linha lisa. Vide os exemplos nas Figuras 7 e 8) como valores culturais; analisando classes de sona e os algoritmos geométricos correspondentes, a construção sistemática de padrões monolineares, regras de composição / encadeamento e de eliminação para a construção de 'sona' monolineares.

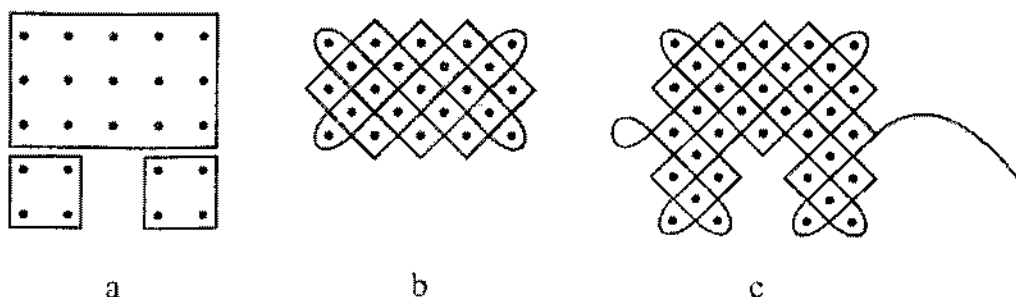

Figure 9

²⁹ M.Ascher, Graphs in cultures (II): a study in ethno-mathematics, *Archive for History of Exact Sciences*, Berlim, 1988, Vol.39, Nº 1, 75-95, e *Ethnomathematics: a multicultural view of mathematical ideas*, Brooks / Cole Publishing Company, Nova Iorque, 1991, 37-43.

³⁰ P.Gerdes, *Geometria Sona: Reflexões sobre uma tradição de desenho em povos da África ao Sul do Equador*, ISP, Maputo, Vol. 1 *Análise e Reconstrução*, 1993, 200 p.; Vol.2 *Exploração educacional e matemática*, 1993, 169 p., Vol. 3 *Análise comparativa*, 1994, 120 p. Edição em Francês: *Une tradition géométrique en Afrique*. — *Les dessins sur le sable*, L'Harmattan, Paris, 1995, 3 vol., 594 p. Edição em Alemão: *Sona Geometrie. Reflektionen über eine sandzeichentradition in südlichen Zentralafrika*, Spectrum, Berlim, 1996, 436 p. (no prelo).

A Figura 9 mostra uma aplicação de uma dessas regras: quando se junta um ou mais redes quadráticas de pontos (no exemplo duas redes 2x2) a uma rede rectangular, cujas dimensões são números sem divisores comuns além de 1 (no exemplo: 3x5), então se se aplicar o mesmo algoritmo da Figura 9b, a figura resultante abraça todos os pontos da rede nova (junta uma cauda e uma cabeça, obtém-se o macaco representado na Figura 9c). Ele sugere que os especialistas de sona, que inventaram essas regras, provavelmente sabiam porque é que as regras são válidas, isto é, eles podiam demonstrar, de uma ou de outra maneira, a verdade dos teoremas exprimidos por essas regras.

Várias experiências foram realizadas com a utilização de sona na educação matemática, na tentativa de valorizar e fazer reviver uma rica tradição científica africana que estava em desaparecimento. ³¹

África sub-Sahariana e o norte de África

As relações entre o desenvolvimento da matemática na África sub-Sahariana e o desenvolvimento da matemática no Egípto Antigo, na África do Norte tanto helenística como islâmica, e no outro lado dos oceanos Índico e Atlântico merecem mais estudo. Na sua obra mais recente, "A Geometria Egípcia", Obenga analisa possíveis laços entre os conhecimentos geométricos do Egípto Antigo e outras partes de África. ³²

21	26	19
20	22	24
25	18	23

'quadrado mágico' do tipo 'Alá' ³³
Figura 10

Desde o aparecimento e divulgação do Islão, as relações entre a África sub-Sahariana e a África do Norte intensificaram-se e / ou estenderam-se. Kani publicou vários trabalhos sobre 'Ilm al-Hisab', ou seja, a aritmética estudada por sábios muçulmanos do Norte de Nigéria. ³⁴ Em "África Conta" (138-151) discute-se a

³¹ Vide P.Gerdes, *Lusona: recreações geométricas de África*, ISP, Maputo, 1991, 117 p. (também publicado em Francês e Inglês) e o 2º volume de "Geometria Sona", que inclui, entre outros, o artigo: On possible uses of traditional Angolan sand drawings in the mathematics classroom, *Educational Studies in Mathematics*, Dordrecht, 1988, Vol.19, No.1, 3-22. Para crianças foi elaborado pelo mesmo autor o livro *Vivendo a matemática: desenhos da África*, Editora Scipione, São Paulo, 1990, 68 p. (Prémio Alba Mahan, 1990; 3ª edição 1994).

³² T.Obenga, *La Géométrie Africaine — Contribution de l'Afrique antique à la Mathématique mondiale*, L'Harmattan, Paris, 1995, 335 p.

³³ A soma dos números em cada fila, coluna e diagonal é igual a 66, sendo 66 o símbolo numérico referente a Alá.

³⁴ A.Kani, Arithmetic in the Pre-Colonial Central Sudan, in: G.Thomas-Emeagwali (org.), *Science and technology in African history with case studies from Nigeria, Sierra Leone, Zimbabwe, and Zambia*, Edwin Mellen Press, Lewiston, 1992. 33-39; Mathematics in the

obra de Muhammed ibn Muhammed, originário de Katsina (no norte da Nigéria actual) e falecido, em 1741, no Cairo, famoso pelo seu trabalho sobre cronogramas, 'quadrados mágicos' e padrões numerológicos. Recentemente, Sesiano editou um dos seus textos sobre a construção de quadrados mágicos de ordem ímpar.³⁵ Os 'Quadrados mágicos' eram usados em amuletos na Nigéria, Niger, Benin e Mali (vide o exemplo na Figura 10). A cidade de Timbuctu (Mali) era um centro do estudo da lógica formal e é o local, onde, em 1991, se achou um manuscrito, cuja caligrafia é típica para a África sub-Sahariana, que parece ter sido escrito por um matemático do Mali, de nome al-Arwani. Uma pesquisa sistemática em bibliotecas e arquivos levará, provavelmente, à descoberta de mais manuscritos matemáticos de sábios maometanos da África sub-Sahariana.

Atravessando os oceanos

Que conhecimentos matemáticos levaram os escravos africanos para as Américas? Que ideias matemáticas sobreviveram de uma ou de outra maneira? 'Mancala' e talvez outros jogos com 'ingredientes' matemáticos são jogados nas Caraíbas e podem ser comparados com os seus 'antepassados' em África. Esta área de investigação está, por enquanto, quase virgem. Um estudo sobre Thomas Fuller (1710-1790), um escravo africano e um prodígio em cálculo, embarcado para a América em 1724, sugere que a investigação etnomatemática possa complementar a análise de fontes escritas. As habilidades extraordinárias de Fuller não podem ser percebidas se não através de um exame mais apurado do contexto cultural que estimulou o seu desenvolvimento.³⁶

Central Bilad Al-Sudan, in: G.Thomas-Emeagwali (org.), *The historical development of science and technology in Nigeria*, Edwin Mellen Press, Lewiston, 1992, 17-36.

35 J.Sesiano, Quelques méthodes arabes de construction des carrés magiques impairs, *Bulletin de la Société Vaudoise des Sciences Naturelles*, 1994, Vol. 83.1, 51-76.

36 J.Fauvel & P.Gerdes, African Slave and Calculating Prodigy: Bicentenary of the Death of Thomas Fuller, *Historia Mathematica*, Nova Iorque, Vol.17, N°.2, 1990, 141-151; Escravo africano e prodígio em cálculo: Bicentário da morte de Thomas Fuller, *AMUCHMA, Revista sobre a História da Matemática em África*, Maputo, 1992, N° 1, 37-48.

FROM URUK TO BABYLON: 4500 YEARS OF MESOPOTAMIAN MATHEMATICS

Eleanor Robson, University of Oxford

Introduction

Many of you will know at least a little about ‘Babylonian’ mathematics. You will know that they counted in sixties, using a strange wedge-shaped writing called cuneiform. You may also know their very accurate approximation to $\sqrt{2}$ and the famous list of Pythagorean triples, Plimpton 322. This kind of information is in most maths history books. So what I want to do today is not to tell you about things which you can easily read about elsewhere, but to give you a context for that mathematics—a quick taste of nearly five millennia of mathematical development and the environmental and societal forces which shaped those changes.

So where are we talking about, and when? The Greek word ‘Mesopotamia’ means ‘between the rivers’. It refers to the land between the Tigris and Euphrates in modern day Iraq, which was conquered by Alexander the Great in 330 BC. But its history goes back a good deal further than that. Mesopotamia was settled from the surrounding hills and mountains during the course of the fifth millennium. It was here that the first sophisticated, urban societies grew up, and here that writing was invented, at the end of the fourth millennium, perhaps in the city of Uruk. Indeed, writing arose directly from the need to record mathematics and accounting: this is the first issue I shall discuss. We shall then move on to the third millennium, to see how counting and measuring systems were standardised in response to the demands of large-scale state bureaucracies. This led in the end to the sexagesimal, or base 60, place value system from which we ultimately derive our hours-minutes-seconds system of measuring time.

By the beginning of the second millennium, though, mathematics had gone beyond the simply utilitarian. This period produced what most of the text-books call ‘Babylonian’ mathematics, although, ironically, it is highly unlikely that any of the maths comes from Babylon itself: the early second millennium city is now deep under the water table and impossible to excavate. We shall be examining the documents written in the scribal schools to look for evidence about how maths was taught at this time, and why it might have become so divorced from its origins. But after the mid-second millennium we have almost no knowledge of mathematical activity in Mesopotamia, until the era of the Greek conquest in the late fourth century BC—when maths from the city of Babylon *is* known. We shall look at *why* there is this enormous gap: was there really very little maths going on, or can we find some other explanations for our lack of evidence?

Counting in clay: from tokens to tablets

But now let us go back to the beginning. Mesopotamia was first inhabited during the mid-fifth millennium BC—i.e. some seven thousand years ago—as the seas and

marshes which had covered it gradually withdrew, leaving a fertile plain with many rivers including the Tigris and Euphrates running through it. Peoples who had already been farming the surrounding hills of the so-called 'Fertile Crescent' for two or three millennia began to settle, first in small villages, and then in increasingly large and sophisticated urban centres. The largest and most complex of these cities were Uruk on the Euphrates, and Susa on the Karkheh river. Exactly why this urban revolution took place need not concern us here: more important to us today are the consequences of that enormous shift in societal organisation.

Although the soil was fertile and the rivers fast, there were two major environmental disadvantages to living in the Mesopotamian plain: firstly, the annual rainfall was not high enough to support crops without artificial irrigation systems, which were in turn vulnerable to destruction when the rivers flooded violently each spring. Secondly, the area yielded a very limited range of natural resources: no metals, minerals, stones or hard timber; just water, mud, reeds and date-palms. Other raw materials had to be imported, by trade or conquest, and utilised sparingly. So mud and reeds were the materials of everyday life: houses and indeed whole cities were made of mud brick and reeds; the irrigation canals and their banks were made of mud, reinforced with reeds, and there were even some experiments in producing agricultural tools such as sickles from fired clay.

It is not surprising then that mud and reeds determined the technologies available for other everyday activities of urban society, such as managing and monitoring labour and commodities. The earliest known method of controlling the flow of goods seems to have been in operation from the mid-fifth millennium, predating the development of writing by some 1500 years. It used small clay 'tokens' or 'counters', made into various geometric or regular shapes. Each 'counter' had both quantitative and qualitative symbolism: it represented a specific number of a specific item. In other words it was not just a case of simple one-to-one correspondence: standard groups or quantities could also be represented by a single token. It is often impossible to identify exactly which object a particular token might have depicted; indeed, when such objects are found on their own or in ambiguous contexts, it is rarely certain whether they were used for accounting at all. The clearest evidence comes when these tokens are found in round clay envelopes. These were often sealed all over with an official's personal cylinder seal to prevent tampering: the envelope could not be opened and tokens removed without damaging the pattern of the seal. In a non-literate society, these cylinder-seals were a crucial way of marking individual responsibility or ownership and, like the tokens, are ideally suited to the medium of clay.

Of course, sealing the token-filled envelopes meant that it was impossible to check on their contents, even legitimately, without the opening the envelope in the presence of the sealing official. This problem was overcome, at some point in the late fourth millennium, by impressing the tokens into the clay of the envelope before they were put inside. It then took little imagination to see that one could do without the envelopes altogether: a deep impression of the tokens on a piece of clay, which could also be sealed by an official, was record enough.

At this stage, c. 3200 BC, we are still dealing with tokens or their impressions which represent both a number and an object in one: a further development saw the separation of the counting system and the objects being counted. Presumably this came about as the range of goods under central control widened and it became unfeasible to create whole new sets of number signs each time a new commodity was introduced to the accounting system. While we see the continuation of impressions for numbers, the objects themselves were now represented on clay either by a drawing of the object itself or of the token it represented, drawn with a sharp reed. Writing had begun.



Now mathematical *operations* could be recorded. This tablet, for instance, shows an addition. The commodities being counted cannot be identified, as the incised signs which represent them have not yet been deciphered. But the numerals themselves, recorded with impressed signs, can be identified with ease. There are in all eighteen D-shaped marks on the front, and three round ones. On the back are eight Ds and four circles, so the circular signs must be equivalent to ten Ds. In fact, we know from other examples that these two signs do indeed represent 1 and 10 units respectively, and were used for counting discrete objects such as people or sheep.

Using methods like this, a team in Berlin have identified a dozen or more different counting systems used on the ancient tablets from Uruk. Each of them is context-dependent: different number bases are used in different situations, although the identical number signs may be used in different relations within those contexts. It is a fearsomely complex system, which has taken many years and a lot of computer power to decipher; the project is still unfinished.

It is unclear what language the written signs represent (if indeed they are language-specific), but the best guess is Sumerian, which was certainly the language of the succeeding stages of writing. But that's another story; it's enough to see that the need to record number and mathematical operations efficiently drove the evolution of recording systems until one day someone put reed to clay and written mathematics began.

The third millennium: maths for bureaucrats

During the third millennium, writing began to be used in a much wider range of contexts, though administration and bureaucracy remained the main function of literacy and numeracy. This greatly hampers our understanding of the political history of the time, although we can give a rough sketch of its structure. Mesopotamia was controlled by numerous city states, each with its own ruler and city god, whose territo-

ries were concentrated on the canals which supplied their water. Because the incline of the Mesopotamian plain is so slight—it falls only around 5 cm in every kilometre—large-scale irrigation works had to feed off the natural watercourses many miles upstream of the settlements they served. Violent floods during each year's spring harvest meant that their upkeep required an enormous annual expenditure. The management of both materials and labour was essential, and quantity surveying is attested prominently in the tablets.

But scribes had to be trained, and from around 2500 BC onwards, we start to find 'school' tablets—documents written for practice and not for working use—including some mathematical exercises. By this time writing was no longer restricted to nouns and numbers, but by using the written signs to represent the *sounds* of the objects they represented and not the objects themselves, scribes were able to record other parts of human speech, and from this we know that the earliest school maths was written in a long-dead language called Sumerian. We currently have a total of about thirty mathematical tablets from three mid-third millennium cities—Shuruppak, Adab and Ebla—but there is no reason to suppose that this represents the full extent of mathematical knowledge at that time. It is often difficult to distinguish between competently written model documents and genuine archival texts: There must be many unrecognised school tablets, from all periods, which have been published as archival material.

Some of the Shuruppak tablets state a single problem and give the numerical answer below. There is no working shown on the tablets, but these are more than simple practical exercises. They use a practical pretext to explore the division properties of the so-called 'remarkable numbers' such as 7, 11, 13, 17 and 19, which are both irregular and prime. We also have a geometrical diagram on a round tablet from Shuruppak and two contemporary tables of squares from Shuruppak and Adab which display consciously sexagesimal characteristics. The contents of the tablets from Ebla are more controversial: according to one interpretation, they contain metrological tables which were used in grain distribution calculations.

Mesopotamia was first unified under a dynasty of kings based at the undiscovered city of Akkad, in the late twenty-fourth century BC. During this time the traditional metrological systems were overhauled and linked together, with new units based on divisions of sixty. Brick sizes and weights were standardised too. The new scheme worked so well that it was not revised until the mid-second millennium, some 800 years later; indeed, as we shall see, some Akkadian brick sizes were still being used in the Greek period, in the late 4th century BC.

There are only eight known tablets containing mathematical problems from the Akkadian period, from Girsu and Nippur. The exercises concern squares and rectangles. They either consist of the statement of a single problem and its numerical answer, or contain two stated problems which are allocated to named students. In these cases the answers are not given, and they appear to have been written by an instructor in preparation for teaching. Indeed, one of these assigned problems has a solved counterpart amongst the problem texts.

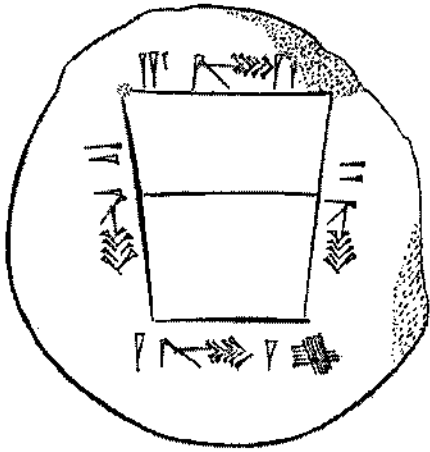

Certain numerical errors suggest that the sexagesimal place system was in use for calculations, at least in prototype form. A round tablet from Nippur shows a mathematical diagram which displays a concern with the construction of problems to produce integer solutions. The trapezoid has a transversal line parallel to the base, dividing it into two parts of equal area. The lengths of the sides are chosen in such a way that the length of the transversal line can be expressed in whole numbers.

No mathematical tables are known from this period, but model documents of various kinds have been identified, including a practice account from Eshnunna and several land surveys and building plans. In working documents too, we see a more sophisticated approach to construction and labour management, based on the new metrological systems. The aim was to predict not only the raw materials but also the manpower needed to complete state-funded agricultural, irrigation and construction projects: an aim which was realised at the close of the millennium.

The empire of the Third Dynasty of Ur (Ur III) began to expand rapidly towards the east in the second quarter of the 21st century BC. At its widest extent it stretched to the foothills of the Zagros mountains, encompassing the cities of Uruk, Ashur, Eshnunna and Susa. To cope with the upkeep of these new territories and the vastly increased taxation revenues they brought in, large-scale administrative and economic reforms were executed over the same period, producing a highly centralised bureaucratic state, with virtually every aspect of its economic life subordinated to the overriding objective of the maximisation of gains. These administrative innovations included the creation of an enormous bureaucratic apparatus, as well as of a system of scribal schools that provided highly uniform scribal and administrative training for the prospective members of the bureaucracy. Although little is yet known of Ur III scribal education, a high degree of uniformity must have been essential to produce such wholesale standardisation in the bureaucratic system. Scribal schools at Nippur and Ur indoctrinated future bureaucrats with the propaganda of empire and the charismatic force of the king.

As yet only a few school mathematical texts can be dated with any certainty to the Ur III period, but between them they reveal a good deal about contemporary educational practice. There are two serious obstacles to the confident identification of school texts from the Ur III period when, as is often the case, they are neither dated nor excavated from well-defined find-spots. Firstly, there is the problem of distinguishing between competently written documents and those produced by working scribes. Secondly, palaeographic criteria must be used to assign a period to them. In many cases it is matter of dispute whether a text is from the late third millennium or was written using archaising script in the early second millennium. In particular, it was long thought that the sexagesimal place system, which represents numerals using

just tens and units signs, was an innovation of the OB period so that any text using that notation was assumed to date from the early second millennium or later. However, we now know that it was already in use by around 2050 BC—and that the conceptual framework for it had been under construction for several hundred years. Crucially, though, calculations in sexagesimal notation were made on temporary tablets which were then moistened and erased for reuse after the calculation had been transferred to an archival document *in standard notation*.

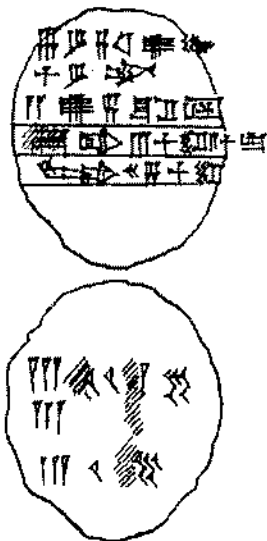

This procedure is succinctly illustrated by a round model document from Girsu. On one side of the tablet is a (slightly incorrect) model entry from a quantity survey, giving the dimensions of a wall and the number of bricks in it. The measurements of the wall are given in standard metrological units, but were (mis-)copied on to the reverse in sexagesimal notation. The volume of the wall, and the number of bricks in it, were then worked out using the sexagesimal numeration, and converted back into standard volume and area measure, in which systems they were written on the obverse of the tablet. These conversions were presumably facilitated by the use of metrological tables similar to the many thousands of Old Babylonian exemplars known. In other words, scribal students were already in the Ur III period

taught to perform their calculations—in sexagesimal notation—on tablets separate from the model documents to which they pertained, which were written in the ubiquitous mixed system of notation.

The writer of this tablet might easily have gone on to calculate the labour required to make the bricks, carry them to building site, mix the mortar, and to construct the wall itself. These standard assumptions about work rates were at the heart of the regime's bureaucracy. Surveyors' estimates of a work gang's expected outputs were kept alongside records of their actual performances—for tasks as diverse as milling flour to clearing fallow fields. At the end of each administrative year, accounts were drawn up, summarising the expected and true productivity of each team. In cases of shortfall, the foreman was responsible for catching up the following year; but work credits could not be carried over. The constants used in these administrative calculations are found in contemporary school practice texts too.

Maths education in the early second millennium

But that totalitarian hyper-controlled regime could not last, and within a century the Ur III empire had collapsed under the weight of its own bureaucracy. The dawn of the second millennium BC—the so-called Old Babylonian period—saw the rebirth of the small city states, much as had existed 500 years before. But now many of the economic functions of the central administration were deregulated and contracted out to private enterprise. Numerate scribes were still in demand, though, and we have an unprecedented quantity of tablets giving direct or indirect information on their

training. Many thousands of school tablets survive although they are for the most part unprovenanced, having been dug up at the end of the 19th century (AD!) before the advent of scientific archaeology. However, mathematical tablets have been properly excavated from a dozen or so sites, from Mari by the Euphrates on the Syria-Iraq border to Susa in south-west Iran. Some of them were written by the teachers, while others were 'exercise tablets' composed by the apprentice scribes. One of the main reasons for this, it appears, is that Sumerian, which had been the official language of the Ur III state, was no longer spoken by most people. Akkadian, a Semitic language related to Hebrew and Arabic, had become the *lingua franca*, while Sumerian was reserved for scholarly and religious writings —analogous to the use of Latin in Europe until very recently. This meant that much of the scribal training which traditionally been oral was recorded in clay for the first time, either in its original Sumerian, or in Akkadian translation, as was the case for mathematics.

Maths was part of a curriculum which also included Sumerian grammar and literature, as well as practice in writing the sorts of tablets that working scribes would need. These included letters, legal contracts and various types of business document, as well as more mathematically orientated documents such as accounts, land surveys and house plans. Five further types of school mathematical text have been identified, each of which served a separate pedagogical function. Each type has antecedents in the third millennium tablets I have just been discussing.

First, students wrote out *tables* while memorising metrological and arithmetical relationships. There was a standard set of multiplication tables, as well as aids for division, and finding squares and square roots. Many scribes made copies for use at work too. *Calculations* were carried out, in formal layouts, on small round tablets—called 'hand tablets'—very like the third millennium examples illustrated above. Hand tablets served as the scribes' 'rough books' and could also carry diagrams and short notes as well as handwriting practice and extracts from literature. The teacher set mathematical problems from 'textbooks'—usually called *problem texts* in the modern literature—which consisted of a series of (often minimally different) problems and their numerical answers. They might also contain model solutions and diagrams. Students sometimes copied problem texts, but they were for the most part composed and transmitted by the scribal teachers. Teachers also kept *solution lists* containing alternative sets of parameters, all of which would give integer answers for individual problems. There were also tables of technical constants—conventionally known as *coefficient lists*—many of whose entries are numerically identical to the constants used by the personnel managers of Ur III.

Model solutions, in the form of algorithmic instructions, were not only didactically similar to other types of educational text, but were also intrinsic to the very way mathematics was conceived. For instance, the problems which have conventionally been classified as 'second degree algebra' have recently turned out to be concerned with a sort of cut-and-paste geometry. As the student followed the instructions of the model solution, it would have been clear that the method was right—because it worked—so that no proof was actually needed.

Although the bottom line for OB education must have been to produce literate and numerate scribes, those students were also instilled with the aesthetic pleasure of mathematics for its own sake. Although many ostensibly practical scenarios were used a pretext for setting non-utilitarian problems, and often involved Ur III-style technical constants, they had little concern with accurate mathematical modelling. Let us take the topic of grain-piles as an example. In the first sixteen problems of a problem text from Sippar the measurements of the grain-pile remain the same, while each parameter is calculated in turn. The first few problems are missing, but judging from other texts we would expect them to be on finding the length, then the width, height, etc. The first preserved problem concerns finding the volume of the top half of the pile. One could imagine how such techniques might be useful to a surveyor making the first estimate of the capacity of a grain-pile after harvest—and indeed we know indirectly of similar late third millennium measuring techniques. However, then things start to get complicated. The remaining problems give data such as the sum of the length and top, or the difference between the length and the thickness, or even the statement that the width is equal to half of the length plus 1. It is hardly likely that an agricultural overseer would ever find himself needing to solve this sort of a problem in the course of a working day.



Similarly, although the mathematical grain-pile is a realistic shape, even simply calculating its volume involves some rather sophisticated three-dimensional geometry, at the cutting edge of OB mathematics as we know it. Further, it appears that at some point the scenario was further refined to enable

mathematically more elegant solutions to be used in a tablet from Susa. In both sets of problems the pile is 60 m long and 18-24 m high. It is difficult to imagine how a grain pile this big could ever be constructed, let alone measured with a stick. In short, the accurate mathematical modelling of the real world was not a priority of Old Babylonian mathematics; rather it was concerned with approximations to it that were both *good enough* and mathematically pleasing.

The evidence for mathematical methods in the workplace is still sketchy, but for instance, I have been working on Old Babylonian canal and land surveys in the Ashmolean Museum in Oxford. Although these look rather different to their late third millennium precursors—they are laid out in the form of tables, with the length, width and depth of each excavation in a separate column—the mathematical principles involved are essentially the same. There is one important difference though: there is no evidence (as yet) for work-rate calculations. This is not surprising: we are not dealing with a centralised ‘national’ bureaucracy in the early second millennium, but quasi-market economies in which much of the work traditionally managed by the state was often contracted out to private firms bound by legal agreements. One would not expect a consistent picture of quantitative management practices throughout Mesopotamia, even where such activities were documented.

What happened next? Tracing the path to Hellenistic Babylon

But after around 1600 BC mathematical activity appears to come to an abrupt halt in and around Mesopotamia. Can it simply be that maths was no longer written down, or can we find some other explanation for the missing evidence?

For a start, it should be said that there is a sudden lack of tablets of *all* kinds, not just school mathematics. The middle of the second millennium BC was a turbulent time, with large population movements and a good deal of political and social upheaval. This must have adversely affected the educational situation. But there is the added complication that few sites of this period have been dug, and that further, the tablets which *have* been excavated have been studied very little: few scholars have been interested in this period of history, partly because the documents it has left are so difficult to decipher.

But further, from the 12th century BC onwards the Aramaic language began to take over from Akkadian as the everyday vehicle of both written and oral communication. Aramaic was from the same language-family as Akkadian, but had adopted a new technology: it was written in with ink on various perishable materials, using an alphabet instead of the old system of syllables on clay. Cuneiform and Akkadian were retained for a much more restricted set of uses, and it may be that maths was not one of them. It appears too that cuneiform was starting to be written in another new medium: on wax-covered ivory writing-boards, which could be melted down and smoothed off as necessary. Although contemporary illustrations and references on clay tablets indicate that these boards were in widespread use, only two have been recovered—both in watery contexts which aided their preservation—but the wax had long since disappeared from their surfaces.

These factors of history, preservation and fashions in modern scholarship have combined to mean that the period between around 1600 and 1000 BC in south Mesopotamia is still a veritable dark age for us. This is beginning to change, though, and there is no reason why school texts, including mathematics should not start to be identified, supposing that they are there to be spotted. But, fortunately for us, the art of writing on clay did not entirely die out, and there are a few clues available already. Mathematical and metrological tables continued to be copied and learnt by apprentice scribes: they have been found as far afield as Ashur on the Tigris and Ugarit on the Mediterranean coast. One also finds evidence of non-literate mathematical concepts, which have a distinctly traditional flavour. Not only do brick sizes remain more or less constant—which strongly suggests that the third millennium metrology was still in use—but there are also some beautiful and sophisticated examples of geometrical decoration. There are, for instance, stunning patterned ‘carpets’ carved in stone from eighth and seventh century Neo-Assyrian palaces—an empire more renowned for its brutal deportations and obsession with astrology than for its contributions to cultural heritage.

But perhaps more excitingly, a mathematical problem is known in no less than three different copies. This would be exciting enough for the mathematically-rich

Old Babylonian period, but for the barren aftermath it is truly sensational. On the other hand, it may be an indication of the reduced repertoire of problems in circulation at this time. Its style shows that mathematical traditions of the early second millennium had not died out, while apparently new scenarios for setting problems had developed. It is a teacher's problem text, for a student to solve, and it is couched in exactly the sort of language known from the Old Babylonian period. But interestingly it uses a new pretext: the problem ostensibly concerns distances between the stars, though in fact it is about dealing with division by irregular numbers—a topic which, as we have seen, goes back as far as the mid-third millennium.

Finally we arrive in Babylon itself—a little after the Persians and Greeks did. By the fourth and third centuries BC indigenous Mesopotamian civilisation was dying. Some of the large merchant families of Uruk and Babylon still used tablets to record their transactions, but the temple libraries were the principal keepers of cuneiform culture. Their collections included huge series of omens, historical chronicles, mythological and religious literature as well as records of astronomical observations. It has often been said that mathematics by now consisted entirely of mathematical methods for astronomy, but that is not strictly true. As well as the mathematical tables—now much lengthier and sophisticated than in earlier times—we know of at least half a dozen tablets containing non-astronomical mathematical problems for solution. Although the terminology and conceptualisation has changed since Old Babylonian times—which, after all, is only to be expected—the topics and phraseology clearly belong to the same stream of tradition. For instance, I have recently discovered a small fragment of a table of technical constants, which contains a list of brick sizes and densities. Although the mathematics involved is of an unprecedented level of sophistication, the brick sizes themselves are *exactly identical* to those invented in the reforms of Akkad around two thousand years before.

Conclusions

I hope I have been able to give you a little taste of the rich variety of Mesopotamian maths that has come down to us. Its period of development is vast: there is twice the timespan between the first identifiable accounting tokens and the latest known mathematical tablet as there is between that tablet and us. Most crucially, though, I hope that you will agree with me that mathematics is fundamentally a product of society. Its history is made immeasurably richer by the study of the cultures which have produced it, wherever and whenever they might be.

Bibliography

For a bibliography on Mesopotamian mathematics and history, contact me at:

The Oriental Institute
Oxford OX1 2LE
UK

or: Wolfson College
Oxford OX2 6UD
UK

eleanor.robson@orinst.ox.ac.uk

eleanor.robson@wolfson.ox.ac.uk

EGYPTIAN MATHEMATICS

Victor J. Katz, University of the District of Columbia

Egyptian civilization dates back five thousand years or more. Although there are few documents going back that far, there is evidence from archaeology that the Egyptians developed some basic mathematical concepts at an early time. The major mathematical documents that exist date from the first half of the second millennium B.C.E. - the *Rhind Mathematical Papyrus* and the *Moscow Mathematical Papyrus*. The *Rhind Mathematical Papyrus* was named for the Scotsman A. H. Rhind, who purchased it at Luxor in 1858, while the *Moscow Mathematical Papyrus* was purchased in 1893 by V. S. Golenishchev, who later sold it to the Moscow Museum of Fine Arts. The former papyrus was copied about 1650 B.C.E. by the scribe A'h-mose from an original about 200 years earlier and is approximately 6 meters long and 30 centimeters high. The latter papyrus dates from probably a bit earlier and is about 5 meters long, but only some 10 centimeters high. Both of these papyri are collections of problems, generally with solutions worked out, which enable us to understand the types of questions the Egyptians considered and the techniques they employed.

We will begin our discussion with a brief overview of the Egyptian numeration system, then deal with some of the algebraic and geometric questions the Egyptian scribes considered, and conclude with some speculation on the influence of Egyptian mathematics on later cultures, in particular on Greek mathematics.

There are two distinct Egyptian numeration systems, both of them having 10 as a base. The first was the grouping system used in the hieroglyphic writing which dots the tombs and temples of ancient Egypt. In this system, each of the first several powers of ten was represented by a different symbol, beginning with the familiar vertical stroke for 1.

	∩	∞	⋈	⊏
1	10	100	1000	10000

But when the scribes wrote on papyrus, as in the documents already mentioned, they developed the hieratic system of numeration, an example of a ciphered system. Here each number from 1 to 9 had a specific symbol, as did each multiple of 10 from 10 to 90 and each multiple of 100 from 100 to 900, etc. Then any given number was written by putting together the appropriate symbols. So, for example, 37 is written by putting the symbol for 7 next to that for 30: 2 7

1	2	3	4	5	6	7	8	9
10	20	30	40	50	60	70	80	90
100	200	300	400	500	600	700	800	900

In neither of these systems, of course, is there any need for a symbol for zero. And in fact, one does not appear in Egyptian mathematical works. But the Egyptians certainly understood the concept of zero, because such a symbol does appear in other kinds of Egyptian papyri, among them, papyri dealing with architecture and levels, where zero is used to indicate the boundary between measurements taken above a certain level and those taken below.

Once we have a system of numbers, we can consider the methods of calculation. In the hieroglyphic system, naturally, addition is quite simple: combine the units, then the ten, then the hundreds, and so on. Whenever a group of ten of one type of symbol appears, replace it by one of the next. Subtraction was equally easy. Such an algorithm no longer works in the hieratic ciphered system, but we have no evidence as to how these operations were performed. Probably, there were addition tables available, but, of course, a competent scribe would have memorized them.

The Egyptian algorithm for multiplication was based on a continual doubling process. To multiply two numbers, the scribe would double the multiplicand repeatedly, all the while recording the partial multipliers, until the next doubling would exceed the original multiplier. For example, to multiply 12 by 13 the scribe would set down the following lines:

-	1	12
	2	24
-	4	48
-	8	96

At this point, the scribe noticed that the next doubling would give 16, which is larger than 13. He would then check off those multipliers which added to 13, namely 1, 4, and 8, and add the corresponding numbers in the other column. The

result would be written as: Totals: 13 156.

Division is done similarly, at least when the result is an integer. But when fractions are used, the Egyptians only dealt with unit fractions, with the exception of $2/3$, perhaps because these fractions were the most natural. Since it is only unit fractions which are recorded, the Egyptians needed a scheme for representing what we would consider common fractions with numerators greater than one in terms of distinct unit fractions. And although we are not certain of the precise algorithm they used, we note that the *Rhind Mathematical Papyrus* contains an extensive table of how to double every unit fraction with odd denominator from $1/3$ to $1/101$. Thus, for example

$$\begin{aligned}2 (1/7) &= 1/4 + 1/28 \\2 (1/15) &= 1/3 + 1/15 \\2 (1/35) &= 1/30 + 1/42 \\2 (1/95) &= 1/60 + 1/380 + 1/570\end{aligned}$$

The problems of the *Rhind Mathematical Papyrus* are of several types. Many of the problems are seemingly practical problems dealing with loaves of bread and scoops of flour. But others are more abstract, including what are generally known as the *aha* (heap) problems. These problems, in the form of what we call linear equations, are solved through the method of false position. For example, problem 24 asks to find a quantity which when it is added to $1/7$ of itself becomes 19. The first "guess" is 7, because $1/7$ of 7 is a whole number. But since $1/7$ of 7 plus 7 gives 8 and not 19, the scribe uses his knowledge of proportionality to refine the guess: namely, since 19 divided by 8 gives $2 + 1/4 + 1/8$, the scribe must multiply 7 by that value to get the answer to the problem: $16 + 1/2 + 1/8$ (or $16 \frac{5}{8}$).

A more complicated problem involving proportions is Problem 40, in which 100 loaves are to be divided among 5 men so that the shares are in arithmetical progression and so that the sum of the two smallest shares is one-seventh of the sum of the three greatest. The scribe first works out an arithmetical progression summing to 60 which satisfies the final condition, namely 1, $6 + 1/2$, 12, $17 + 1/2$, 23; he then multiplies each share by the quotient of 100 by 60, namely $1 + 2/3$.

In the *Moscow Papyrus*, we see that the Egyptians could also solve linear equations using modern techniques. Thus, to find the number such that if it is taken $1 \frac{1}{2}$ times and then 4 is added, the sum is 10, the scribe first subtracts 4 from 10 to get 6, then multiplies 6 by $2/3$ (the reciprocal of $1 \frac{1}{2}$) to get 4 as the solution. Similarly, problem 31 of the *Rhind Papyrus* asks to find a quantity such that the sum of itself, its $2/3$, its $1/2$, and its $1/7$ become 33; that is, to find x such

that

$$x + (2/3)x + (1/2)x + (1/7)x = 33.$$

The problem is not conceptually difficult, but it is arithmetically challenging. It was probably included to demonstrate methods of division, for the scribe solved the problem by dividing 33 by $1 + 2/3 + 1/2 + 1/7$ to get

$$14 + 1/4 + 1/56 + 1/97 + 1/194 + 1/388 + 1/679 + 1/776$$

There are other types of algebraic problems in the papyri, but the more interesting problems in both the *Rhind* and *Moscow Papyri* are the geometric ones. We first consider the Egyptian procedure for determining the area of a circle, detailed in, for example, problem 50 of the *Rhind Papyrus*: Example of a round field of diameter 9. What is its area? The solution is given as: Take away 1/9 of the diameter, namely 1; the remainder is 8. Multiply 8 times 8; it makes 64. Therefore the area is 64. Apparently, the Egyptian scribe is using the formula $A = (d - d/9)^2 = [(8/9)d]^2 = (64/81)d^2$. This amounts to taking $\pi/4 = 64/81$ or $\pi = 256/81 = 3.16049\dots$ How did the Egyptians determine this procedure? One possibility is that they looked at a circle and octagon inscribed in a square. It appears that the area of the circle is approximately that of the octagon, which in turn is $7/9$ of the square.

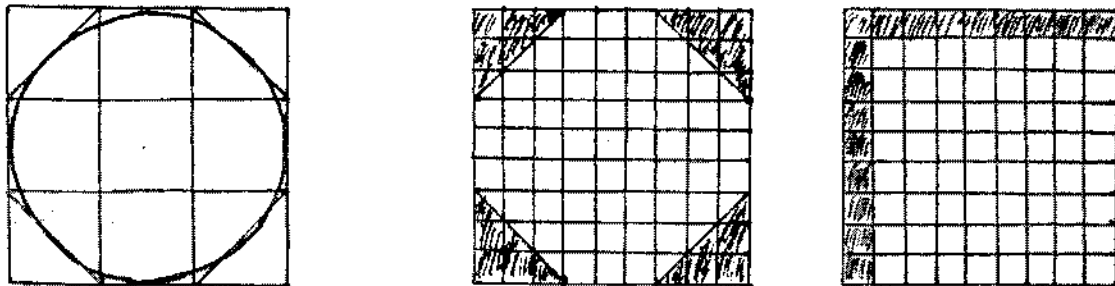

So one might think that the scribe would give the formula as $A = (7/9)d^2 = (63/81)d^2$. But, as attested in other places at other times, the problem may really have been to "square the circle", i.e., to find a square whose area was equal to the given circle. We can therefore think of the octagon as being inscribed in a 9×9 square (of area 81). The shaded triangles on the top are equal to the top row of shaded squares, while the shaded triangles on the bottom are equal to the left hand column. If one removes both (one square twice), we get a square of side $8/9$ of the original which closely approximates the area of the octagon and therefore the circle. This reconstruction may clarify what the scribe means by "take away 1/9 of the diameter" and then squaring the remainder.

The Egyptians were also able to calculate the area of plane figures bounded by straight lines, including triangles and trapezoids. But we now turn to some problems in solid geometry. Given that the Egyptians built numerous pyramids as burial places for their kings, it is a surprise that there is no explicit documentation of a procedure for finding the volume of a pyramid. There is, however, a problem in the *Moscow Papyrus* which gives explicit directions for determining the volume of a truncated pyramid with square bases 2 and 4 and height 6.

If it is said to thee, a truncated pyramid of 6 cubits in height, of 4 cubits of the base, by 2 of the top. Reckon thou with this 4, squaring. Result 16. Double thou this 4. Result 8. Reckon thou with this 2, squaring. Result 4. Add together this 16 with this 8 and with this 4. Result 28. Calculate thou one third of 6. Result 2. Calculate thou with 28 twice. Result 56. Lo! It is 56! Thou has found rightly.

These directions imply that the Egyptian procedure for finding the volume of a truncated pyramid with lower base of side a , upper base of side b , and height h can be written as the formula: $V = (h/3)(a^2 + ab + b^2)$.

Most commentators have assumed that if the Egyptians knew a formula for a truncated pyramid, they certainly also knew the formula for a completed pyramid. Obviously, one only needs to replace a by 0 in the formula. And the here. Assuming they knew the correct pyramid formula, how did they discover it? And, given that formula, how did they work out the formula for the volume of a truncated pyramid. There have been various dissection arguments given to answer the second question, but none are very obvious. The obvious way (to us) to determine this formula is to subtract the volume of the "missing" top from the volume of the entire pyramid. But this method involves factoring the expression $a^3 - b^3$ as well as a knowledge of similarity. Could the Egyptians do this? We don't know. We do know, however, that the Egyptians were familiar with proportional reasoning, as noted in the *aha* problems as well as others in the *Rhind Papyrus*. But more generally, the Egyptians used grids for architecture and art and were certainly familiar with ways of using grids for a plan for a building at some scale and then enlarging to build the real thing.

The answer to the first question is equally difficult. According to Archimedes, the formula for the volume of a pyramid was "proved" by Eudoxus (408-355 B.C.E.) (using exhaustion techniques), but first "stated" by Democritus (5th century B.C.E.) (without a valid proof). Archimedes does not mention the Egyptians at all. What kind of an argument would Democritus have given? Since what we know about Democritus is that he used "infinitesimals", we might surmise

that his argument involved adding up volumes of infinitesimally thin layers which make up the pyramid. But assuming the Egyptians knew this result and since, after all, the Egyptians build pyramids layer upon layer, perhaps they also "derived" the formula via a similar argument. There are various possible arguments using "layers" which would enable the Egyptians to guess the correct formula for the volume of a pyramid.

Let us now consider one other interesting formula for solid figures. The Moscow papyrus gives a formula for the surface area of a basket in the form of a curved surface. It is not entirely clear whether this surface is a half cylinder or whether is a half of a sphere. The preponderant argument from those who have studied the language of the text carefully is that it is the latter. If we assume this, then the Egyptians have given a formula for the surface area of a sphere equivalent to $A = 4\pi r^2$. The problem giving this result is problem 10 of the *Moscow Mathematical Papyrus*.

Method of calculating a basket. If it is said to thee, a basket with an opening of $4 \frac{1}{2}$ in its containing, oh! Let me know its surface. Calculate thou $\frac{1}{9}$ of 9, because the basket is the half of an egg. There results 1. Calculate thou the remainder as 8. Calculate thou $\frac{1}{9}$ of 8. There results $\frac{2}{3} + \frac{1}{6} + \frac{1}{18}$. Calculate thou the remainder of these 8 left, after taking away these $\frac{2}{3} + \frac{1}{6} + \frac{1}{18}$. There results $7 + \frac{1}{9}$. Reckon thou with $7 + \frac{1}{9}$, $4 \frac{1}{2}$ times. There results 32. Lo! this is its area. You have done it correctly.

Let us consider the solution in modern terms. We are given a hemisphere of diameter $d = 4 \frac{1}{2}$. The scribe first doubles the diameter to get $2d = 9$. He then finds $\frac{8}{9}$ of $2d$, or $2 \times \frac{8}{9} \times d$. (This value is 8.) The scribe next calculates $\frac{8}{9}$ of this value: $2 \times \frac{8}{9} \times \frac{8}{9} \times d (= 7 \frac{1}{9})$. Finally, he multiplies this result by $d = 4 \frac{1}{2}$ to get 32. In other words, he has calculated that

$$A = 2 \times \frac{64}{81} \times d^2 = 2 \times \frac{256}{81} r^2 = 2\pi r^2$$

since, as discussed before, the Egyptian value for π was $\frac{256}{81}$.

This same result appears in the work of Archimedes with a rigorous proof, proposition 33 of *On the Sphere and Cylinder I*. Archimedes gives no sources for this result. In fact, in the preface to that work he notes "These properties [which includes other results than this one] were all along naturally inherent already in the figures referred to, but they were unknown to those who were before our time engaged in the study of geometry..." Thus Archimedes is claiming that he himself was the "discoverer" of the result. But since the formula was known in Egypt,

we must conclude that Archimedes was mistaken, probably unknowingly. We still want to ask, however, how the Egyptians figured out this formula? Was it from an empirical study of how much straw you need to weave a hemispherical basket? Did basketmakers learn over the years that they needed twice as much material for the basket as for the lid? Or is there some analytic way of determining this result?

The question of these area and volume formulas points to a more general question which is currently being debated widely - what was the influence (if any) of Egyptian mathematics (and more generally of Egyptian science) on Greek mathematics (or science). In the book *Black Athena*, Martin Bernal claims that significant portions of classical Greek culture were strongly influenced by ancient Egyptian civilization, partly, in fact, through the colonization of parts of Greece from Egypt. Bernal further asserts that although the classical Greeks themselves recognized and acknowledged this influence, European scholars of the eighteenth and nineteenth century rewrote history to deny African influence on the progenitors of European civilization. *Black Athena* is a massive and still incomplete work, which brings together evidence from linguistics, theology, philosophy, archaeology and other disciplines, but does not deal specifically with the history of science itself. In an article in *Isis*, Bernal attempted to summarize his views on that history in particular, in relation to his general thesis.

There are two basic questions to be answered, first whether there were "scientific" elements in Egyptian medicine, mathematics, and astronomy long before there was any Greek science at all; and, second, whether Egyptian medicine, mathematics, and astronomy critically influenced the corresponding Greek disciplines.

Let us consider these two ideas briefly. One can clearly argue about the meaning of "scientific" elements in Egyptian mathematics. The Egyptians certainly knew how to solve various kinds of problems, from solving linear equations to calculating the area of - let us assume - the surface of a hemisphere. What we do not know, because the documents don't tell us, is how the Egyptian scribes found the methods they use. Presumably, if they simply "guessed" correctly, then one could say that they did not have a "scientific" mathematics. But if they had some kind of argument - and not necessarily an argument based on strict logical reasoning from explicit axioms - I think one must conclude that their mathematics had a "scientific" underpinning.

But on the other issue of whether Egyptian mathematics influenced Greek mathematics, I think there is good evidence that we must take the answer as "yes". After all, many of the ancient Greek sources say so. Not only is Pythagoras supposed to have studied in Egypt, but also Thales, the supposed father of Greek geometry, and Eudoxus. And Herodotus, Heron of Alexandria, Diodorus

Siculus, Strabo, Socrates (through Plato), and Aristotle all say that geometry was first invented by the Egyptians and then passed on to the Greeks. The question always seems to be, in this regard, what we mean by "geometry". If we mean by geometry an axiomatic treatment with theorems and proofs in the style of Euclid, then it is clear that the Greeks originated this. But mathematicians have always known that, in general, one does not discover theorems by the axiomatic method. One discovers theorems by experiment, by trial and error, by induction, by thinking hard about the subject, etc. Only after the discovery is made does one worry about actually proving that what you have proposed is correct. And it seems clear that when Greek writers mention that the Egyptians invented (or discovered) geometry, it is the geometric results that they mean, not the method of proof.

For example, let us consider the formula for the volume of a square pyramid, which most historians agree must have been known to the Egyptians even though there is no specific text dealing with it. But then Archimedes claims that Eudoxus was the first to prove this result. I will not argue the question of whether Eudoxus learned the proof in Egypt. So let us assume that he did give the first "rigorous" proof of the formula, probably through a *reductio* argument based on the method of exhaustion, a proof similar to that in Euclid, Book XII. But what then? The question still remains, how did Eudoxus know the formula to be proved? Archimedes claims that Democritus was the first to state the result. If we take that claim literally, then Archimedes is simply mistaken. What is also possible, and even probable from what we know of Democritus, is that he gave a "proof" by a method of indivisibles which was not rigorous according to Euclidean (or Archimedean) standards. But if that were so, then we would still have to ask, how did Democritus know the result? Archimedes himself notes, in the preface to his *Method*, that "it is easier to supply the proof [of a geometrical result] when we have previously acquired, by the method, some knowledge of the questions than it is to find it without any previous knowledge." So if, in fact, the Egyptians knew the formula for the volume of a pyramid, and if, as seems likely from all the testimonies, the Greeks learned of this result from the Egyptians, then one must credit the Egyptians with "influencing" Greek geometry, even if the Egyptians did not have a "proof" of their result. The same is naturally true with regard to other results, including the formulas for the area of a circle and, let us assume, for the area of a hemisphere. One can also consider the basic ideas of proportionality as being present in Egyptian mathematics and could conceive of these too as "influencing" Greek understanding of that subject as well. And although formal Greek mathematics does not deal with the notion of fractions, we do know that in their informal mathematical calculations, the Greeks often used the Egyptian system of unit fractions.

Most historians credit the Greeks with being the first people to deal with the

notion of proof, at least in the modern sense. In fact, our own tradition of proof goes back explicitly to Euclid's Elements, whose basic forms of argument can be seen in Aristotle's work, among others. The supposition is made that the Greek tradition of proof grew out of their penchant for argument and debate, which was involved in their many political systems, all of which were based on "law" rather than "fiat." So even though the Greeks record that many of their sages studied mathematics and philosophy in Egypt, it is never made clear - and many historians deny - that in fact the Greeks learned mathematics in Egypt. What we have already said seems to point to the fact that first of all, there was mathematics to be learned there and that there is no particular reason to deny all of the ancient Greek testimonies. Perhaps all they learned was some of the results - and then they went back to Greece and worked out proofs. That would certainly be possible and in accord with the rest of mathematical history. Results are generally figured out first - heuristically or through experiment or good guessing or whatever - and then proofs are worked out, with rigor sufficient for the time. But what is not generally known is that there was also a tradition of argument in Egyptian society, a tradition which also encompassed some of the rules of argument which were later codified by Aristotle and appear in Euclid. So we cannot exclude the possibility that the Greeks even learned some of their ideas of proof from the Egyptians. According to Bernal, at least, there is definite evidence that some of what we know as Greek civilization comes from the Egyptian colonies in Greece in the 14th century B.C. We cannot exclude the possibility that the idea of proof, at least in part, comes from there as well.

It is clear that much more research will need to be done to establish definitive answers to the questions of the influence of Egypt on Greek mathematics.

ANCIENT CHINESE MATHEMATICS

Man-Keung Siu, University of Hong Kong

Let me clarify at the beginning what I set out to do in an introductory lecture as such. I do not intend to give a comprehensive account of ancient Chinese mathematics, since it is difficult, if not impossible, to do justice in a 45-minute lecture to the indigenous mathematical development which spanned over two millenia, up to the end of the 16th century when the first wave of dissemination of European science in China began. (What happened after the 16th century will form a topic by itself, and I will not talk about it in this lecture. In fact I will choose my examples from Chinese mathematics only up to the 13th century. From that point onward, Chinese mathematics was at a standstill and even retrogressed until it was stimulated into activity again a few centuries later.) I would rather attempt to convey a general flavour of ancient Chinese mathematics and illustrate some of its characteristic features through a few examples. (Details of these examples will have to be consigned to a related 90-minute workshop.) In the course of doing that we will have occasion to look at certain related aspects of mathematics education and also at the issue on mathematical proofs. (The latter topic will be further discussed in my talk in a panel on proofs.)

Far from being qualified as a serious historian of mathematics myself, I am greatly indebted to the general accounts and in-depth research works of many writers and historians of mathematics, especially those which are contained in a vast store of books and papers written in Chinese, most of which have not been translated and thus remained inaccessible or even unknown to the non-Chinese-speaking community. I seek pardon of those authors in not documenting their works in full here for lack of space. Instead, for the convenience of readers who do not read Chinese but who wish to go further into the subject, I will cite below a few helpful references available in English.

The most well-known and oft-cited standard reference, an immensely scholarly and well-documented work (with access to over 500 items in Chinese and Japanese) on the whole history of Chinese mathematics written in English for the first time, is of course

- J. NEEDHAM (with the collaboration of WANG Ling), "Science and Civilization in China", vol.3, Chapter 19, Cambridge University Press, Cambridge, 1959.

A more updated reference is

- J.C. MARTZLOFF, "A History of Chinese Mathematics" (translated from "Histoire des mathématiques chinoises", Masson, Paris 1987), Springer-Verlag, Heidelberg, 1996.

For a first reading, two good choices are

- LI Yan and DU Shiran, "Chinese Mathematics: A Concise History" (translated by J.N. CROSSLEY and A.W.C. LUN from "Zhongguo Gudai Shuxue Jianshi", Zhonghua, Beijing, 1963), Clarendon Press, Oxford, 1987;
- G.G. JOSEPH, "The Crest of the Peacock: Non-European Roots of Math-

ematics", Tauris, London, 1991.

For a quick introduction through several informative and interesting articles, one can read

- F.J. SWETZ, The evolution of mathematics in ancient China, *Math. Magazine*, 52 (1979), 10-19;
- F.J. SWETZ, The amazing Chiu Chang Suan Shu, *Math. Teacher*, 65 (1972), 423-430;
- F.J. SWETZ, The "piling up of squares" in ancient China, *Math. Teacher*, 70 (1977), 72-79.

(All three articles above are collected in "From Five Fingers to Infinity: A Journey Through the History of Mathematics", edited by F.J. SWETZ, Open Court, Chicago, 1994.)

A chronological outline of the development of Chinese mathematics with an accompanying extensive bibliography of references written in Western languages (up to 1984) can be found in

- F.J. SWETZ and ANG Tian Se, A brief chronological and bibliographic guide to the history of Chinese mathematics, *Historia Mathematica*, 11 (1984), 39-56.

CHARACTERISTIC FEATURES OF ANCIENT CHINESE MATHEMATICS

We will examine some characteristic features of ancient Chinese mathematics by looking at what the ancient Chinese mathematicians chose to work on and how they worked on it. In the former aspect one discerns a strong social relevance and pragmatic orientation. In the latter aspect one discerns a strong emphasis on calculation and algorithms. However, contrary to the impression most people may have, ancient Chinese mathematics is not just a "cook-book" in applications of mathematics to mundane transactions. It is structured, though not in the Greek tradition exemplified by Euclid's *ELEMENTS*. It includes explanations and proofs, though not in the Greek tradition of deductive logic. It contains theories which far exceed the necessity for mundane transactions.

Let me start with some ideograms (characters) related to mathematics. In ancient classics the term mathematics (數學) was often written as "the art of calculation" (算術) or "the study of calculation" (算學), indicating a deep-rooted basis in calculation. The ideogram for "number" and "to count" (數) appeared on oracle bones about 3000 years ago, in the form of a hand tying knots on a string. The ideogram for "to calculate" (算) appeared in three forms, according to SHUOWEN JIEZI (*Analytic Dictionary of Characters*) by XU Shen (AD 2nd century). The first is a noun, composed of two parts, "bamboo" on top and "to manipulate" in the bottom, with the bottom part itself in the form of two hands plus some (bamboo) sticks laid down on a board, some placed in a horizontal position and some placed in a vertical position. (We will come to that shortly.) The second is a verb, also with the parts of bamboo and hands. The third is somewhat more puzzling, in the form of a pair of ideogramatic parts pertaining to religious matters. It is a

tentalizing thought that the subject of mathematics in ancient China was not exactly the same subject as we understand it today. Indeed, in some ancient mathematical classics we find the mentioning of "internal mathematics" and "external mathematics", the former being intimately tied up with YIJING (Book of Changes), the oldest written classic in China. I do not know enough of the "internal mathematics" to even carry on a conversation, so I will confine my lecture to the "external mathematics".

Besides its appearance in these ideograms, the theme on calculation permeated through the whole of ancient Chinese mathematics. This is best illustrated by the calculating device of the counting rods. Ample evidences substantiate the common usage of counting rods as early as in the 5th century B.C., and they probably developed from sticks used for fortune-telling in even earlier days. The earliest relics from archaeological findings are dated to 2nd Century B.C. These were made of bamboo, wood and even metal, bone or ivory and were carried in a bag hung at the waist. The prescribed length in the literature (verified by the relics) was from 13.86cm to 8.5cm, shortened as time went on. The cross-section changed with time, from circular (of 0.23cm in diameter) to square so that the rods became harder to roll about. One extremely mathematically interesting feature is the occurrence of a red dot on a counting rod to denote a positive number, and a black dot to denote a negative number. These counting rods were placed on a board (or any flat surface) and moved about in performing various calculations.

The Chinese adopted very early in history a denary positional number system. This was already apparent in the numerals inscribed on oracle bones in the Shang Dynasty (c. 1500 B.C.), and was definitely marked in the calculation using counting rods in which the positions of the rods were crucial. Ten symbols sufficed to represent all numbers when they were put in the correct positions. At first only nine symbols were used for the numerals 1 to 9, with the zero represented by an empty space, later by a square in printing, gradually changed to a circle, perhaps when the square was written by a pen-brush. To minimize error in reading a number, numerals were written alternatively in vertical form (for units, hundreds, ...) and horizontal form (for tens, thousands, ...). In a much later mathematical classic, XIAHOU YANG SUANJING (Mathematical Manual of Xiahou Yang) of the 5th century, this method for writing counting rod numerals was recorded as: "Units stand vertical, tens are horizontal, hundreds stand, thousands lie down. Thousands and tens look the same, ten thousands and hundreds look alike. Once bigger than six, five is on top; six does not accumulate, five does not stand alone." For instance, 1996 will be written as $\text{— IIII} \equiv \text{— T}$.

If you have practiced calculation using counting rods, you will no doubt notice several weak points about it. (1) The calculation may take up a large space. (2) Disruption during the calculation can be disastrous. (3) The calculating procedure is not recorded step by step so that intermediate calculations are lost. Counting rods evolved into the abacus in the 12th-13th centuries, and by the 15th century abacus took the place of counting rods. The weak points (1) and (2) were removed by the use of abacus, but (3) remained, until

the European method of calculation using pen and paper was transmitted in the beginning of the 17th century. However, calculation using counting rods had its strong points. Not only did the positions of the counting rods display numerals conveniently, the positions these counting rods were placed on the board also afforded a means to allow some implicit use of symbolic manipulation, giving rise to successful treatment of ratio and proportion, fractions, decimal fractions, very large or very small numbers, equations etc. Indeed, the use of counting rods was instrumental in the whole development of mathematics in ancient China.

Even a casual reading of a few mathematical classics will disclose the unmistakable features of social relevance and pragmatic orientation. From the very beginning mathematical development was intimately related to studies on astronomical measurement and calendrical reckoning. The first written text containing serious mathematics, ZHOUBI SUANJING (Zhou Gnomon Classic of Calculation) compiled at about 100 B.C. with its content dated to earlier times, was basically a text in astronomical study. In an ancient society based on agriculture, calendrical reckoning was always a major function of the government. Along with that, mathematics was performed mainly for bureaucratic needs. A 6th century mathematics classic actually carried the title WUCAO SUANJING (Mathematical Manual of the Five Government Departments). The titles of the nine chapters of the most important mathematical classic JIUZHANG SUANSHU (Nine Chapters on the Mathematical Art), which is believed to have been compiled some time between 100 B.C. and A.D. 100, speak for themselves. These are (1) survey of land, (2) millet and rice (percentage and proportion), (3) distribution by progression, (4) diminishing breadth (square root), (5) consultation on engineering works (volume of solid figures), (6) impartial taxation (allegation), (7) excess and deficiency (Chinese "Rule of Double False Positions"), (8) calculating by tabulation (simultaneous equations), (9) gou-gu (right triangles). The social relevance of the content of mathematical classics was so plentiful that historians have found in them a valuable source for tracing the economy, political system, social habits and legal regulations of the time! The emphasis on social relevance and pragmatic orientation, in line with a basic tenet of traditional Chinese philosophy of life shared by the class of "shi" (intellectuals), viz. self-improvement and social interaction, was also exhibited in the education system in which training in mathematics at official schools was intended for government officials and clerks. (For further discussion on mathematics education in ancient China, see M.K. Siu, Mathematics education in ancient China: What lesson do we learn from it? *Historia Scientiarum*, 4-3 (1995), 223-232.)

As to the issue on mathematical proofs, let me quote from a paper I wrote a few years ago. "If one means by a proof a deductive demonstration of a statement based on clearly formulated definitions and postulates, then it is true that one finds no proof in ancient Chinese mathematics, nor for that matter in other ancient oriental mathematical cultures. ... But if one means by a proof any explanatory note which serves to convince and to enlighten,

then one finds an abundance of proofs in ancient mathematical texts other than those of the Greeks.” (See M.K. Siu, Proofs and pedagogy in ancient China: Examples from Liu Hui’s commentary on JIU ZHANG SUAN SHU, Educational Studies in Mathematics, 24 (1993), 345-357. The paper contains a number of illustrative examples.) We will see in the section on some examples how the Chinese offered proofs through pictures, analogies, generic examples and algorithmic calculations. These can be of pedagogical value to complement and supplement the teaching of mathematics with traditional emphasis on deductive logical thinking.

JIUZHANG SUANSHU

JIUZHANG SUANSHU is the most important of all mathematical classics in China. It is a conglomeration of 246 mathematical problems grouped into nine chapters. There is good reason to believe that the content of JIUZHANG SUANSHU was much older than its date of compilation, as substantiated by an exciting archaeological finding in 1983 when a book written on bamboo strips bearing the title SUANSHU SHU (Book on the Mathematical Art) was excavated. It is dated at around 200 B.C. and its content exhibits a marked resemblance to that of JIUZHANG SUANSHU, including even some identical numerical data which appeared in the problems. The format of JIUZHANG SUANSHU became a prototype for all Chinese mathematical classics in the subsequent one-and-a-half millenia. A few problems of the same category were given, along with answers, after which a general method (algorithm) followed. In the very early edition that was all and no further explanation was supplied, that being perhaps supplied by the teacher. Later editions were appended with commentaries which explained the methods, corrected mistakes handed down from the ancients, or expanded the original text. The most notable commentator of JIUZHANG SUANSHU was LIU Hui (c. 3rd century), some of whose works will be examined in the next section.

The format of JIUZHANG SUANSHU may lead one to regard the book as a medley of recipes for solving problems of specific types. Indeed many who studied from the book in the official system in ancient China might have actually regarded the book as such and thus resorted to rote learning just like in recitation of other classics. This may explain why only a handful of mathematicians of some standing were produced from the tens of thousands of “mathocrats” who went through mathematical training in the official system during two millenia, while almost all noted mathematicians in history were either self-educated or studied at private academies.

However, this is not true upon closer scrutiny. The body of knowledge contained in a classic such as JIUZHANG SUANSHU is structured around several themes, the two main themes being the concept of “lu” (率 , ratio) in arithmetic and the concept of “gou-gu” (勾股 , right triangle) in geometry. I will briefly describe how ratio forms a backbone for most chapters, and leave right triangle to the next section. In the commentary of Chapter 1, LIU Hui gave a definition: “a ratio is a relation between numbers”. (Compare

this with Definition 3 of Book 5 of Euclid's *ELEMENTS*: "A ratio is a sort of relation in respect of size between two magnitudes of the same kind".) He continued to offer a working definition of ratio by representing it as a reduced fraction. (Today we know that strictly speaking a ratio is not a number, and all the more not necessarily a rational number.) To reduce a fraction the rule of "reciprocal subtraction", known to the Westerners as the Euclidean algorithm, was introduced. "If both numerators and denominators are divisible by 2, then halve them both. If they are not both divisible by 2, then set up the numbers for numerator and denominator respectively continually and alternately subtracting the smaller from the larger, and seek their equality." This is a good illustration of how the calculation itself is already a proof (or convincing argument), as can be seen from Problem 6 of Chapter 1: "Reduce the fraction $\frac{49}{91}$."

$$(49, 91) \rightarrow (49, 42) \rightarrow (7, 42) \rightarrow (7, 35) \rightarrow (7, 28) \rightarrow (7, 21) \rightarrow (7, 14) \rightarrow (7, 7)$$

Hence $49 = 7 \times 7$, $91 = 7 \times 13$, and $\frac{49}{91} = \frac{7}{13}$. At the beginning of Chapter 2 LIU Hui explained the so-called "Rule of Three" (also found in contemporary Indian manuscripts), which enables one to apply the concept of ratio to a number of situations, including distribution in direct proportions or in inverse proportions (Chapters 3, 6), formulation and treatment of problems in excess and deficiency, i.e. the method of "double false positions" (Chapter 7), and system of simultaneous linear equations (Chapter 8). Although the Chinese terminology "fangcheng" (方程), which is the title of Chapter 8, was adopted as a translation for "equation" towards the end of the last century (and becomes a standard term today) for a wrong but historically interesting reason, the spirit of Chapter 8 lies rather in the direction of ratio than in the direction of equation. In light of ratios the technique amounting to the modern matrix method by Gaussian elimination arises naturally.

To end this section, let me give an example which blends together social relevance, ratio and even an application in sampling. It is Problem 6 of Book 12 of *SHUSHU JIUZHANG* (Mathematical Treatise in Nine Sections) by QIN Jiushao, published in 1247: "When a peasant paid tax to the government granary in the form of 1534 shi of rice, it was found out on examination that a certain amount of rice with husks was present. A sample of 254 grains was taken for further examination. Of these 28 grains were with husks. How many genuine grains of rice were there, given that one shao contains 300 grains?" (In the mensuration system of the Song Dynasty, 1 shi = 10 dou = 100 sheng = 1000 he = 10000 shao. According to tradition recorded in *JIUZHANG SUANSHU*, a grain of rice with husk was counted as half a grain of rice.) The answer was given to be 4348346456 grains, out of the original $1534 \times 10000 \times 300 = 4602000000$ grains.

SOME EXAMPLES

(1) Let me start with Problem 14 of Chapter 9 of *JIUZHANG SUANSHU*: "Two persons A (Jia) and B (Yi) stood at the same spot. In the time when

A walked 7 steps, B could walk 3 steps. B walked east and A walked south. After 10 steps south A turned to walk in a roughly northeast direction to meet B. How many steps had each walked (when they met)?"

The rule that follows the problem essentially gives the ratio of the length a, b, c of the three sides of a right triangle with c as that of the hypotenuse, viz.

$$a : b : c = \frac{1}{2}(m^2 - n^2) : mn : \frac{1}{2}(m^2 + n^2),$$

where $m : n = (a + c) : b$. In Problem 14, $m = 7$, $n = 3$ and $a = 10$. Hence $a : b : c = 20 : 21 : 29$ and $b = 10\frac{1}{2}$, $c = 14\frac{1}{2}$. The mathematical meaning of this result goes much deeper than just an answer to the problem as it stands, for it offers a way to generate the so-called Pythagorean triplets, i.e. (positive) integers a, b, c with $a^2 + b^2 = c^2$. I am not implying the such an explicit formula for Pythagorean triplets (given by the ancient Greeks) was stated by the ancient Chinese, but I do imply that they were quite well-versed in such types of problems in which their Greek contemporaries were also interested, and that in ancient Chinese mathematics arithmetic and geometry were intertwined through calculation. The achievement becomes all the more astounding if one notes that the ancient Chinese were unaware of the notion of prime number and factorization as did their Greek contemporaries. Instead, the Chinese adopted a geometric viewpoint by looking for two quantities with suitable geometric interpretation in terms of which a, b, c can each be rationally expressed. In the case of Problem 14, the two quantities are the sum of the length of one side and the hypotenuse ($a + c$) and the length of the third side (b). (By the way, in these days when many students are weak in their feel for geometry, such examples, of which Problem 14 is only one out of many, may be of pedagogical interest.) Let me summarize the explanation offered by LUI Hui in the following pictures, which I hope can speak for themselves. In his commentary LIU Hui actually described in detail how to make use of coloured pieces and to reassemble them for a convincing argument. If the original diagrams of the commentary were extant, they would make nice visual aids!

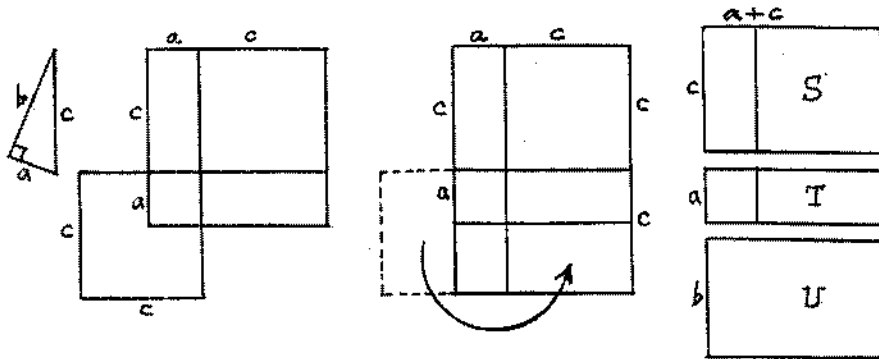

From the picture we can see that

$$\begin{aligned} c : a : b &= S : T : U \\ &= \frac{1}{2}[(a+c)^2 + b^2] : (a+c)^2 - \frac{1}{2}[(a+c)^2 + b^2] : (a+c)b. \end{aligned}$$

Hence

$$\begin{aligned} a : b : c &= \frac{1}{2}[(a+c)^2 - b^2] : (a+c)b : \frac{1}{2}[(a+c)^2 + b^2] \\ &= \frac{1}{2}(m^2 - n^2) : mn : \frac{1}{2}(m^2 + n^2) , \end{aligned}$$

where $(a+c) : b = m : n$.

To illustrate the influence of this prototype classic of JIUZHANG SUANSHU, let me continue with a possible interesting aftermath of the formula derived above. This has to do with Problem 2 of Chapter 5 of SHUSHU JIUZHANG by QIN Jiushao, published more than a thousand years later: "A triangular field has sides of length 13 miles, 14 miles and 15 miles. What is its area?" The solution was given in the book as (in modern day mathematical notations)

$$(\text{Area})^2 = \frac{1}{4} \left[A^2 C^2 - \left(\frac{A^2 + C^2 - B^2}{2} \right)^2 \right]$$

where A, B, C are the length of the three sides in decreasing magnitude. This is a rare gem in Chinese mathematics because this was perhaps the one single occurrence of a triangle other than a right triangle in all Chinese mathematical texts before the transmission of Euclid's ELEMENTS into China. One naturally calls to mind the formula by the Greek mathematician Heron of Alexandria (c. 1st century), viz.

$$(\text{Area})^2 = S(S-A)(S-B)(S-C)$$

where $S = (A+B+C)/2$. Indeed, the two formulae are equivalent. Let me outline a probable derivation of the formula by QIN Jiushao. (It is interesting to compare it with the proof of Heron by synthetic geometry, which can be found in, for instance, I. Thomas, "Greek Mathematical Works, II", Harvard University Press, 1939; reprinted with additions and revisions, 1980.) First note that, from our preceding example,

$$\frac{a}{b} = \frac{1}{2}[(a+c)^2 - b^2]/(a+c)b ,$$

so that

$$a = \frac{1}{2} \left[(a+c) - \left(\frac{b^2}{a+c} \right) \right] .$$

Construct a right triangle with sides of length a, b, c (c is the hypotenuse) where a, c are lengths as shown in the following diagram.

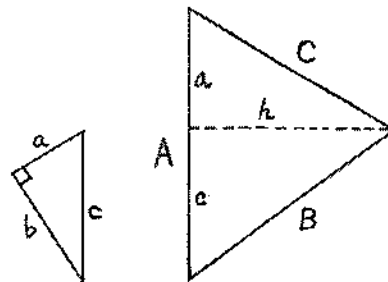

Since $C^2 - a^2 = h^2 = B^2 - c^2$, we have $B^2 - C^2 = c^2 - a^2 = b^2$. Hence

$$a = \frac{1}{2} \left[(a+c) - \left(\frac{b^2}{a+c} \right) \right] = \frac{1}{2} \left[A - \frac{B^2 - C^2}{A} \right] = \frac{1}{2} \left[\frac{A^2 + C^2 - B^2}{A} \right]$$

Finally,

$$\begin{aligned} (\text{Area})^2 &= \frac{1}{4} h^2 A^2 = \frac{1}{4} (C^2 - a^2) A^2 = \frac{1}{4} (A^2 C^2 - a^2 A^2) \\ &= \frac{1}{4} \left[A^2 C^2 - \left(\frac{A^2 + C^2 - B^2}{2} \right)^2 \right] \end{aligned}$$

(2) Calculation of π is never out of place in any historical account, so let me include it here. Problem 32 of Chapter 1 of JIUZHANG SUANSHU asked: "A circular field has a perimeter of 181 steps and a diameter of 60 and $1/3$ steps. What is its area?" The answer was given as "the area equals half the perimeter times half the diameter". This is a correct formula, as one can easily check that $A = (\frac{1}{2}C)(\frac{1}{2}d) = (\frac{1}{2}C)(r) = (\pi r)(r) = \pi r^2$. The data in Problem 32 imply the formula $C = 3d$, which means π was then taken to be 3. In his commentary, LIU Hui explained why the formula is reasonable and pointed out how to obtain a more accurate value for π . He said, "In our calculation we use a more accurate value for the ratio of the circumference to the diameter instead of the ratio that the circumference is 3 to the diameter's 1. The latter ratio is only that of the perimeter of the inscribed regular hexagon to the diameter. Comparing arc with the chord, just like the bow with the string, we see that the circumference exceeds the perimeter. However, those who transmit this method of calculation to the next generation never bother to examine it thoroughly but merely repeat what they learned from their predecessors, thus passing on the error. Without a clear explanation and definite justification it is very difficult to separate truth from fallacy." In this passage we see a truly first-rate mathematician at work, who probes into knowledge handed down and seeks understanding and clarification, thereby extending the frontier of knowledge. Let me explain what LIU Hui did, using modern day mathematical language. Put

- A_n = area of an inscribed regular n -gon in a circle of radius r ,
- a_n = length of a side of the inscribed regular n -gon,
- C_n = perimeter of the inscribed regular n -gon.

Starting with a regular hexagon ($n = 6$) and doubling the number of sides, LIU Hui enlarged it to a regular 12-gon, then a regular 24-gon, then a regular 48-gon, etc. up to a regular 192-gon. He observed that $A_{12} = 3a_6r = \frac{1}{2}C_6r$, $A_{24} = 6a_{12}r = \frac{1}{2}C_{12}r$, $A_{48} = 12a_{24}r = \frac{1}{2}C_{24}r$, etc.

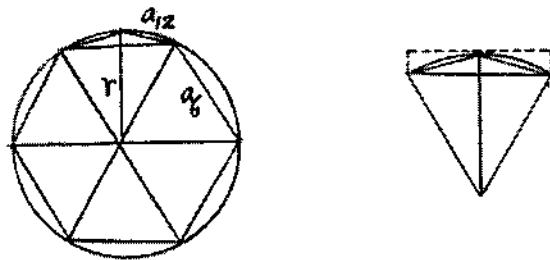

He also knew that this was not the end but only the first few steps in an approximation process. He claimed, "... the finer one cuts, the smaller the

leftover; cut after cut until no more cut is possible, then it coincides with the circle and there is no leftover." We see here the budding concepts of infinitesimal and limit. He even gave an estimate, viz.

$$A_{2m} < A < A_{2m} + (A_{2m} - A_m) ,$$

as can be seen from the picture above. With this he concluded that "ultimately" $A = \frac{1}{2}Cr$. He also carried out the computation for finding A_{192} . In doing that he first established the formula

$$a_{2n} = \sqrt{\left[r - \sqrt{r^2 - \left(\frac{a_n}{2}\right)^2}\right]^2 + (a_n/2)^2} .$$

With the help of a modern computer we can in a flash obtain $A_{192} = 3.141032$ (with $r = 1$) with error term 0.001681. But imagine how LIU Hui did it with only the help of counting rods over 17 centuries ago, obtaining $A_{192} = 314\frac{64}{825}$ (with $r = 10$). Effectively he calculated π accurate to two decimal places. (It is interesting to compare this computation of π with that by Archimedes, which can be found in, for instance, R. Calinger (ed), "Classics of Mathematics", Moore Publishing, 1982; Prentice-Hall, 1995.)

(3) The algorithmic feature of ancient Chinese mathematics can best be illustrated by the method of solving simultaneous linear congruence equations. In abstract algebra there is a fundamental result known as the "Chinese Remainder Theorem". Its name comes from a concrete instance, viz. Problem 26 of Chapter 3 of SUNZI SUANJING (Master Sun's Mathematical Manual, c. 4th century): "There are an unknown number of things. Counting by threes we leave 2; counting by fives we leave 3; counting by sevens we leave 2. Find the number of things." The problem became quite popular and appeared under different names. In a much later text SUANFA TONGZONG (Systematic Treatise on Arithmetic) of CHENG Dawei, published in 1592, there appeared even a poem about it: "T'is hard to find one man of seventy out of three. There are twenty-one branches on five plum blossom trees. When seven persons meet, it is in the middle of the month. Discarding one hundred and five, the problem is done." The poem conceals the magic numbers 70 (for 3), 21 (for 5), 15 (for 7) of this specific problem, whose general answer is $2 \times 70 + 3 \times 21 + 2 \times 15$ plus or minus any multiple of $105 = 3 \times 5 \times 7$. In general, the problem is to solve a system of linear congruence equations

$$x \equiv a_i \pmod{m_i} , \quad i \in \{1, 2, \dots, N\} .$$

Mathematicians were led to investigate linear congruence because of calendrical reckoning and had become quite facile in handling them. Already in this specific problem we can see a very significant step made, viz. reduction of the problem to solving $x \equiv 1 \pmod{m_i}$, $x \equiv 0 \pmod{m_j}$ for $j \neq i$ (the solution to the original problem being a suitable "linear combination" of the solutions of these different systems). The investigation was completed by QIN Jiushao who named his method the "Dayan art of searching for unity" in his SHUSHU JIUZHANG (1247). He showed how to find a set of magic numbers for making

the “linear combination”. Let me illustrate with the case when the m_i 's are mutually relatively prime, using modern notations. (QIN Jiushao also treated the general case.) It suffices to solve separately single linear congruence equations of the form $kb \equiv 1 \pmod{m}$ by putting $m = m_i$ and $b = (m_1 \cdots m_N)/m_i$. The key point in the method QIN Jiushao employed to find k is to find a sequence of ordered pairs (k_i, r_i) such that $k_i b \equiv (-1)^i r_i \pmod{m}$ and the r_i 's are strictly decreasing. At some point $r_s = 1$ but $r_{s-1} > 1$. If s is even, then $k = k_s$ will be a solution. If s is odd, then $k = (r_{s-1} - 1)k_s + k_{s-1}$ will be a solution. This sequence of ordered pairs can be found by using “reciprocal subtraction” explained in JIUZHANG SUANSHU, viz. $r_{i-1} = r_i q_{i+1} + r_{i+1}$ with $r_{i+1} < r_i$ (the process will stop before one reaches the case $r_{i+1} = 0$), and put $k_{i+1} = k_i q_{i+1} + k_{i-1}$. (Put $k_{-1} = 0$, $r_{-1} = m$, $k_0 = 1$, $r_0 = b$.) The way the ancient Chinese performed the calculation was even more streamlined and convenient, since they put consecutive pairs of numbers at the four corners of a board using counting rods, starting with

$$\begin{array}{|c|c|} \hline 1 & b \\ \hline 0 & m \\ \hline \end{array}, \text{ going to } \begin{array}{|c|c|} \hline k & 1 \\ \hline * & * \\ \hline \end{array}.$$

The procedure was stopped when the upper right corner became a 1, hence the name “searching for unity”. A typical intermediate step will look like

$$\begin{array}{|c|c|} \hline k_i & r_i \\ \hline k_{i-1} & r_{i-1} \\ \hline \end{array} \rightarrow \begin{array}{|c|c|} \hline k_i & r_i \\ \hline k_{i-1} & r_{i+1} \\ \hline \end{array} \rightarrow \begin{array}{|c|c|} \hline k_i & r_i \\ \hline k_{i+1} & r_{i+1} \\ \hline \end{array}, \text{ if } i \text{ is even}$$

or

$$\begin{array}{|c|c|} \hline k_{i-1} & r_{i-1} \\ \hline k_i & r_i \\ \hline \end{array} \rightarrow \begin{array}{|c|c|} \hline k_{i-1} & r_{i+1} \\ \hline k_i & r_i \\ \hline \end{array} \rightarrow \begin{array}{|c|c|} \hline k_{i+1} & r_{i+1} \\ \hline k_i & r_i \\ \hline \end{array}, \text{ if } i \text{ is odd.}$$

You can see how the positions on a board of counting rods help to fix ideas. In fact, the procedure outlined in SHUSHU JIUZHANG can be phrased word for word as a computer program!

(4) Let me end with an example on the lighter side. Problem 34 of Chapter 3 of SUNZI SUANJING said: “One sees 9 embankments outside; each embankment has 9 trees; each tree has 9 branches; each branch has 9 nests; each nest has 9 birds; each bird has 9 young birds; each young bird has 9 feathers; each feather has 9 colours. How many are there of each?” The problem, an easy exercise in raising a number to certain powers, is not of much interest in itself. What is interesting is the frequent occurrence of such problem of a recreational nature in all mathematical civilizations. The medieval European mathematician, Leonardo Fibonacci posed a problem in his book “Liber Abaci” (1202): “Seven old women went to Rome; each woman had seven mules; each mule carried seven sacks; each sack contained seven loaves; and with each loaf were seven knives; each knife was put up in seven sheaths. How many are there, people and things?” It reminds us of a children’s rhyme: “As I was going to Saint Ives, I met a man with seven wives. Every wife had seven sacks. Every sack had seven cats. Every cat had seven kits. Kits, cats, sacks and wives, how many were there going to Saint Ives?” And then there was that similar Problem 79 in the oldest extant mathematical text, the Rhind Papyrus of ancient Egypt (c. 17 century B.C.):

Houses	7
Cats	49
Mice	343
Heads of wheat	2301
Hekat measures	<u>16807</u>
	19607

Well, David Hilbert (1862-1943) once said, "Mathematics knows no races
... For mathematics, the whole cultural world is a single country."

INDIAN MATHEMATICS AND ITS EVOLUTION

P. Rajagopal, Atkinson College, York University, Toronto, Canada

Abstract

A mathematical tradition beginning from about -1000; six periods in each of which mathematics was expanded, added to and launched forward ("programmes of mathematics");
 The *Sulvasutras* (about -800); constructional geometry; use of irrational numbers; the *Sthaananga sutra* (-300), the first enumeration of 'what is mathematics?'; philosophical and literary ideas of zero;
 Aryabhata (499) extends the programme by introducing solutions of first order indeterminate equations; the *Bakshali Manuscript*;
 Brahmagupta (628), Sridhara (750), Mahavira (850); arithmetic; computable zero, negative numbers; paradigms for problem solving; indeterminate equations of the first degree;
 Bhaskara II (1150); "mathematics of zero"; geometric derivations of algebraic results; solutions to the so-called Pell equations;
 Narayana (1356)
 Madhava, Nilakanta and others (1400 and later); derivation of infinite series for $\arcsin x$, $\arctan x$; rectification of the circle and values for $\pi/4$;
 Ramchundra (1850); maxima and minima in differential calculus using methods of algebra; attempts to graft calculus methods on to a Sanskrit base;
 Which brings the development to about 1880; it would be a fitting conclusion to mention Ramanujan but he did not build on a Sanskrit base but rediscovered Western mathematics on his own.

1) Introduction

In India mathematics has been studied and used from about -1000 (little has been deciphered from the remains of the Indus Valley Civilization which was wiped out by about -1750). One can identify six periods in each of which mathematics was developed, expanded, added to and launched forward; they can be thought of as "programmes of mathematics". Astronomy, astrology, prosody, music, and architecture are some of the areas which were enriched by mathematics at various times. Mathematics was developing at the same time as the language Sanskrit was; it was codified by Panini (who lived about -350), who wrote a grammar using metalinguistic constructs and transformational grammars.

Scholars who wrote about mathematics must have been familiar with Sanskrit grammar, as well as logic, epistemology and philosophy.

It may be useful to make a comment about the word "Indian". Many English writers of the last two centuries have used the word "Hindu" instead. The Arab writers of the 8th to 10th centuries used phrases like "mathematics of the Indi people" or "mathematics in the manner of the people of the Indus" which were rendered as "Hindu" in translations but nowadays that word has come to refer to a religion of the subcontinent. In fact contributions to Indian mathematics has been made by followers of Jainism and Buddhism as well as of Hinduism. The word "Indian" avoids reference to any particular religious affiliation.

Indian contributions to mathematics have been the subject of controversy with respect to their independent origin. While some people find everything in Indian mathematics to be of Greek or of Chinese origin, equally exaggerated claims have been made for the Indian origin of scientific and philosophic ideas. This study of the scientific record attempts to show the underlying and fundamental unity of Indian contributions to mathematics. While such evidence cannot be conclusive, combined with the external evidence we have, it points to notable dependence of modern mathematics upon the Indian inspiration. The mathematical genius of India has, from earliest times down to the most recent, sought its expression in computation and numerical relationships. Not only in arithmetic and algebra is this true, but equally in geometry, astronomy, and in other sciences including linguistics. Numbers (including zero) may be said to be the first universal language of Indian mathematics.

The intimate relationship between Sanskrit and mathematics, and the need for brevity (for oral transmission) must be kept in mind when we study Indian mathematics. It meant that the root texts were composed in verse which followed the rules of Sanskrit prosody and composition. They included conventions for rendering numbers into metrical syllables, and as a result they were pithy and brief, which facilitated memorization. The exigencies of the metre often necessitated the omission of parts of mathematical formulas or algorithms, and contributed to imprecision of technical terminology forcing the poet to substitute one term for another. This did not matter too much as long as the texts that were taught were orally passed on; such oral transmission was often accompanied by interpretation, commentary or what we would call exercise sessions. This was possible in a stable society which was valued its knowledge and was not subject to external threats or invasions. Internal rivalries usually guaranteed cultural continuity. External invasion, especially followers of an intolerant religion, was another matter; after about 1100 Islamic invasions had a dramatic effect. They tore the fabric of society, and this had an effect on both the quality and continuity of Indian mathematics (Rajagopal 1994).

2) The Beginnings (-800 to 400)

In the *Sulvasutras*, which are part of the religious texts of the Hindus, methods for geometrical constructions are described. The texts are from about -1000 to about -700; the *Sulvasutras* are appendices to one of the four *Vedas* which are sacred texts of India. The constructions described are for altars; once an altar of specified shape and area was built a sacrificial fire was lit on the altar and offerings (of milk, honey, fruits, clarified butter and so on) were made to be carried by *Agni*, the god of fire, to the divine addressees. Shapes for altars included geometrical figures like triangles, rectangles, semi-circles, trapezia, rectangles with a semi-circle on one side and so on; the constructions are for drawing such figures of a given area, as well as drawing one of area equal to another. The areas were large; if the height of a person was one unit, the areas of the altars were about 7.5 square units (about 25 square metres or about 250 square feet). There are also constructions for figures (whose areas are equal to those mentioned earlier) with more exotic shapes such as those of a tortoise, a flying bird, or a flying bird with bent tails; the area of such figures were calculated by subdivision into smaller pieces of known geometric shapes).

The geometrical constructions in the *Sulvasutras* appear as if they are stated for magnitudes being represented by segments. (take the length of this, cut off equal segment on that, join these two, draw a circular arc, and so on). Also provided are algorithms for the calculation of several irrational numbers; these are often referred to in the text (construct an area that is $\sqrt{2}$ times such and such or construct a length that is $\sqrt{3}$ times this). Formally these books do not mention irrational numbers or incommensurability; but their authors use segments and numbers (rational, irrational, integral) with equal facility. It is difficult to treat these as algebra or geometry (or as is sometimes claimed geometric algebra). They needed altars and they used methods which gave them the required geometric figures; the fabric of mathematics was made of a seamless web. (Thibaut 1875, Sen and Bag 1983, Datta 1932, Seidenberg 1983).

In the period around -500 two other religious movements, Buddhism and Jainism, originated in India. Neither began with the intention of starting a new religion; each was a protest movement, objecting to the orthodox formalistic and ritualistic aspects of Hinduism, especially as they became rigid; but in course of time they became new religions. However followers of both the religions, rooted as they were in the cultural milieu in which arithmetic and geometry were an integral part, contributed to the advancement of mathematics. While they were not interested in shapes of altars, they turned their attention to

the study of cosmology, the worlds out there and the succession of oceans and continents, both in this planet and in other parts of the universe. Recursive definitions and relations were used to derive large and very large numbers (numbers in the decimal base but with exponents as large as 81 or even 163). The Jains were especially interested in the classification of knowledge; in a book called the *Sthaanangasutra* (from about -300) there are page after page of classifications of knowledge (mental, moral, physical, animal, plant, and everything they observed or they could think of). The version of the *Sthaanangasutra* we know is one edited by Abhayadevasuri, who also added a commentary. One verse is about mathematics; it sets out to describe "what is mathematics" by giving a list of all of its parts. According to that verse the topics for discussion in mathematics are the following: fundamental operations (of arithmetic), geometry, mensuration of solid bodies, fractions, simple equations, quadratic equations, numbers in patterns (permutations, combinations, figurate numbers) and their summations, squares and higher powers, square roots and lower roots, estimates of the volume of heaps and stacks. Included in the list are arithmetic, algebra, geometry and practical problems. Noteworthy is the fact that the topic on equations contains the phrase "that which is" referring to the unknown that has to be found (these are problems which would be solved by starting with: *let the unknown be x*) (Rajagopal 1991). For the next 1000 years this list - or should we call it the curriculum? - was used in subsequent works. While some of them listed the arithmetic operations or expanded the different bodies and shapes, the list persisted till about the time of Bhaskara II (1150).

The metaphysical ideas were also part of this development, and so it is not easy to untangle the corpus of ideas which include philosophical and literary speculations on zero, the logical underpinnings for those ideas in knowledge representation, and the language for writing about them precisely. This part of Indian logic was developed between -150 and 400. Scholars refer to these developments as including ancient logic and medieval logic, even though they were independent and they continued to flourish until about 1000. Indian logic provided criteria for the structure of discourse; it included ideas related to terminology, evidence, proof, persuasion, demonstration and techniques of presentation. Scholars of the time assumed that the readers knew Sanskrit; they accepted all this as part of rhetoric; so did writers on mathematics.

This was also the period when the concept of zero occurred in philosophical and speculative thought (emptiness, nothingness, what is when you see nothing, and so on); the Indian religious texts (the *Vedas*, which contain chants and some of the philosophical appendices called the *Upanishads*) contain these metaphysical reflections and speculations. These were carried forward into the literary works (drama, poetry). In different

verses zero was used to refer to the dark void; the stars were referred to as zero dots; the mysterious thoughts in the eyes of the beloved were referred to as "being as deep as zero". We have no record of how audiences reacted to such references to concepts representing nothing or void when they heard them in plays or poems. These two periods, of the philosophical zero and of the literary zero, were followed later by the third period in which the computable zero was introduced by Brahmagupta (628).

The period of the *Sutras* was also important in the development of the political culture of India (as well as the foundation of the religions of the Hindus, the Buddhists, and the Jains). There were a series of invasions from the regions north-west of India, each of which brought new settlers who brought with them their religious heroes, heroines, and speculative reflections (about the universe, the cosmos, the nature of what is out there, and about the vertical relations of God to humans and the horizontal relationships of human to human). In course of time these were absorbed and synthesized into the stories found in the famous epics in their present form - the *Mahabharata* and the *Ramayana*. In the same period also arose ideals of the Indian emperor - the *Chakravartin* - who was the overseer of god's rule on earth: fair, impartial, supporter of scholarship and justice, and tolerant of all religions. These ideals continued to hold sway until about 1100 or so. The next three periods of developments in mathematics (in sections 3, 4, and 5) were all centred in the capitals of the empires of such *Chakravartins*.

3) The period of Aryabhata (476 to 600)

Aryabhata wrote a small but terse book which included astronomy and mathematics. The verses on mathematics were about one-third of a book of about 120 verses (most of them being in two lines). He also wrote other books on astronomical calculations, on reckoning of ephemeris (tables of the rising and setting times of planets and other luminaries). But his fame was based on the small book: *Aryabhatiya*. Aryabhata's writings clearly convey his readiness to set new standards and break into new areas. He writes about planetary paths and conjunctions; he assumes a simultaneous conjunction of all planets at the commencement of the epoch and from that assumption he sets up indeterminate equations (one equation in two variables); and he gives algorithms for the solutions. These solutions give the next successive crossing of the planets. When his calculations did not agree with observations he revised his epochal assumptions. Since he was writing all this for the first time he is neither laden with the weight of the power of the received idea nor is he inhibited with having to defend to those spouting dogma. He was working in a court (in Pataliputra) which included others who were also exploring new dimensions (in drama, in poetry, in linguistics, and in logic). There is no indication in his writing of tinkering with planetary constants in attempts to

reconcile theory with observation. He gives an explanation of solar and lunar eclipses (and describes a way of using his ephemeris for the prediction of eclipses). In one verse he gives the table for the calculation of the sine function (ratio of half chord to half diameter) from zero degrees to ninety degrees by steps of 3.75 degrees, and for the intermediate values he gives the required interpolation rules. (Indian sine is always a reference to the product *radius times sine*; so the table would give *sine 90* to be not 1.0 but the radius of the circle he used, namely 3438). He also refers to *versine* (which is related to our *cosine* as follows: $\text{cosine } \theta = r - \text{versine } \theta$).

Indeterminate equations and trigonometric functions (*sine* and *versine*) are new topics in his book but in the mathematical verses he follows and describes all of the "table of contents" listed in the *Sthaanangasutra*. He refers to four elements in the universe (earth, air, fire, and water) but not the fifth (ether) which is usually included in Hindu cosmology. These have been cited by some scholars to speculate that Aryabhata may have been a Jain and not a Hindu.

Untrammelled by predecessor's writings, and uninhibited by tradition he blazed a path all his own, including the terseness of his writings. He wrote about systems which used sunrise time, or midnight time, as the starting point of calculations for his ephemeris. He used his own conventions about rendering numbers into metrical syllables. As a result they were pithy and brief, and also facilitated memorization. About hundred years later Bhaskara I (625) wrote a commentary on the *Aryabhatiya*; it included expansions of several verses, it included the formulae for interpolation, gave "clarifications" of the algorithms for the indeterminate equations, and gave a number of graded exercises. Bhaskara's commentary shows the need for such a commentary barely a century after the publication of the root text (Shukla 1976). There exist several hundred commentaries on the *Aryabhatiya*: some are revised editions, some are in other languages, some are expository notes but all of them begin with translations of the original verses. In spite of the fame of authors like Brahmagupta (628) and Bhaskara II (1150) whose texts were to eclipse those of Aryabhata in northern and central India in the South the Aryabhata school was firmly embedded. It may be worth mentioning that there was a mathematician called Vararuci in South India; he is often referred to as the father figure in the astronomical and mathematical tradition of South India. References to him place him around 300 to 400; he had a unique system for writing numbers using the letters of the alphabet (known as the *katapayadi* system); most of the planetary and calendrical calculations of Aryabhata resemble those attributed to Vararuci. Some scholars have proposed that Aryabhata was born in South India but gravitated to the Imperial Court of Pataliputra, and that his early training was based on the systems of Vararuci. We have no more evidence to substantiate this

claim than we have to find out whether Aryabhata was a Jain.

Associated with this period, but from a different part of the country, is the *Bakhshali Manuscript*. Bakhshali is a village in the north-west of the Indian sub-continent (near modern day Peshawar), and is at the crossroads of commercial routes. The manuscript is an anonymous compendium of rules, illustrative examples together with their solutions; it may well be a commentary on a lost text). The examples are all related to daily life (commercial examples, about mixtures of noble and base metals, about money and interest, and about algorithms for successive estimates of square and cube roots which are used in the exercises). Also found in the manuscript are the use of a symbol for zero and the use of the phrase "that which is" for the unknown. None of the exercises are based on astronomical; or calendrical calculations, making it the first book on mathematics. The text may also have been of non-Hindu origin. There has been some controversy about the date of the manuscript. Dating based on the language, the script and the units of currency differ from dating based on the type of examples and the methods of solutions. North-west India was invaded by the White Huns in the period beginning about 430; they left a trail of destruction and plunder. The use of the phrase "that which is unknown" (found in the *Sthaanangasutra*) and the period of the Hun invasions leaves us with the conclusion that the manuscript belongs to the period between -300 and 400. We also know more about the popular dialect in which some of the manuscript is written. New translations as well as a concordance of words used in books of the fifth to seventh centuries indicate that it could be earlier than Aryabhata's works (Hoernle 1887, Kaye 1927, Hayashi 1985).

4) Brahmagupta (628 to 900)

Brahmagupta (628) was the first author who wrote about zero as a computable number and treated it along with other decimals in doing arithmetic. He also recognised that zero separated the positive numbers from the negative numbers. He wrote about arithmetic with negative numbers. The "computable zero" ushers in the third phase in the "technology of zero and the decimals". To be able to use zero like any other number was thus the final phase of its role in mathematics; the ultimate unreality of signifying nothing by a symbol and including it into the symbolic technology of mathematics was thus achieved over three to four centuries of reflection, understanding and then operations.

The mathematical works of Brahmagupta are found in two chapters of the *Brahmasphutasiddhanta* (= corrected astronomical system according to Brahma). The first chapter on *patiganita* (= arithmetic) includes all the topics in the standard ten-part table of contents. Of special interest is his exhaustive investigation of triangles and cyclic quadrilaterals. Among the

topics discussed in the chapter on algebra, in addition to a thorough treatment of indeterminate equations of the first degree itself, are the mathematics of zero and surds, quadratic equations, equations of several unknowns, and indeterminate equations of the second degree. Lagrange's methods for indeterminate equations resemble those of Brahmagupta (Colebrooke 1817). One important development that has a dramatic effect on the West: about the year 770 Brahmagupta's works were brought to the court of the Caliph al-Mansur in Baghdad, and they were translated by al-Fazzari into Arabic. For a number of words in Sanskrit for which there were no Arabic words al-Fazzari rendered Sanskrit words into Arabic. Arab interest in astronomy began with their acquaintance with Indian astronomy; they got to know about Ptolemy's work much later. About a century later at the behest of Caliph al-Mamun al-Khwarizmi wrote popularizations of the arithmetic. The passage of this knowledge from Baghdad to Damascus and eventually in 1202 into the *Liber Abaci* of Leonardo of Pisa is well-known.

Two authors of this period who are authors of popular books are Sridhara (750) and Mahavira (850). Sridhara wrote a book on mathematics and also a shortened version of the same. Only half of the book on mathematics has been found; the abbreviated version gives an idea of what the rest of the book was about. His book contains a geometric presentation of arithmetic and geometric progressions as well as some other results. Mahavira (850) deserves to be mentioned as the author of the first text book in mathematics: for each topic he gives terminology, notation, rules, illustrative examples, followed by exercises for the reader. He even has sections on "devilishly clever exercises" for the advanced pupil! (Rangacharya 1912). There are a number of translations of Mahavira's book into other Indian languages.

One of the applications of the mathematical knowledge was to architecture, in particular to the building of temples. Several of the famous temples (including the cave temples of Ajanta and Ellora) were constructed in the period up to about 900 or so; temple construction continued in South India until about 1600 or so because of the "delay" in the repercussions of Islamic invasions reaching the South). The political stability of the country and the tolerance of rulers (usually Hindu) to the followers of other religions (Buddhist or Jain) resulted in the availability of royal munificence for grand constructions. Indian temples usually were finished in the reign of the king who initially gave approval for them; the use of mathematics in the design, in the estimation of the required material, and in the calculations needed to achieve the required coordination between the celestial criteria and the earthly layout, followed by implementation are a standing tribute to the accomplishments of a numerate society (Maanikka 1985).

5) Bhaskara II (1100 to 1400)

The second Bhaskara (1150) wrote two works on mathematics. The *Lilavati* on arithmetic contains all the standard topics as well as sections on permutations, combinations, and an extensive discussion of the mathematics of zero. This became the standard book on arithmetic in India; hundreds of manuscript copies of the book are in libraries all over India. It was also translated into several Indian languages. Less popular than the *Lilavati*, because it is more difficult, was Bhaskara's *Bijaganita*. It is the standard text book on algebra and describes arithmetical operations involving positive and negative numbers as well as zero; irrational numbers; indeterminate equations of the first degree (virtually the same chapter as in *Lilavati*); the cyclic solution to the second order indeterminate equation (which is referred to in modern books as the Pell equation); various kinds of linear and quadratic equations with one or more unknowns; and equations involving products of unknowns. *Lilavati* and *Bijaganita* came to occupy a central position in the eyes of Indians as the best of Indian mathematics (Colebrooke 1817). These two books were actually part of *Siddhantasiromani* (the crown jewel of astronomical systems).

In spite of the significant work on algebra, the relative weakness in geometry had a stultifying influence on the development of Indian mathematics and more so of astronomy. It was actually the geometric equipment of Kepler, among his other gifts which was decisive in enabling him to come up with true kinematics of planetary motion whereas Indian astronomers, including the stalwarts of the South Indian school, kept on endlessly tinkering with planetary constants in their attempts to reconcile theory with observation and failed miserably because they could not conceive of motion in a curve other than a circle - the power of the received idea - and also because they lacked the courage to question the dogmas underlying their planetary theory: that of a simultaneous conjunction of all planets at the commencement of the epoch and that of a common uniform velocity of all planets.

However there is one idea of Bhaskara's which was a departure from the standard: perpetual motion. In his *Siddhantasiromani* there are two constructions for machines of perpetual motion. In India the idea of perpetual motion was entirely consistent with, and was perhaps rooted in, the Hindu concept of the cyclical self-perpetuating nature of all things. Almost immediately it was picked up in Islam where it amplified the tradition of automata. Islam of A.D. 1200 served as intermediary in transmitting the Indian concept of perpetual motion to Europe, just as it was transmitting Hindu numerals and positional reckoning at the same moment: Leonardo of Pisa's *Liber Abaci* appeared in 1202.

After Bhaskara II the next major authority on mathematics was Narayana (1356) who wrote the *Ganitakaumudi*. In addition to the usual topics (of the ten-topic table of contents) he has sections on magic squares, on quadratic indeterminate equations, and on combinations as well as a table of binomial coefficients (known in the West as Pascal triangle).

By the time of Bhaskara II the ancient and medieval schools of Indian logic had merged into *navya nyaya* (= modern logic). Gangesa (13th century) wrote a definitive text; and Raghunatha Siromani (late 15th century) wrote revisions and expositions. They include the equivalents of distributive laws and deMorgan's laws of our symbolic logic (Ingalls (1951)).

As was pointed out at the end of section (2) the three periods - of Aryabhata, Brahmagupta and Bhaskara II were in state capitals which were the centre of the imperial courts of kings (who saw themselves as *Chakravarthins* or emperors). The period of the Hun invasion had a devastating effect on the north-west of India but even that part of India recovered from the blow. The period between 300 and 1000 was one of relative stability in Indian political conditions (except for the time of the Hun invasions). Indian rulers were preoccupied with their own rivalries and were often involved in their internal geo-political concerns. They had no shared sense of being part of any thing larger than their own kingdoms; they were unprepared for the next invader: the people of Islam. Starting from about 1000 wave after wave of invasions left India unprepared for the onslaught. Here is a paragraph from Albiruni's *India*: "Mahmud utterly ruined the prosperity of the country, and performed there wonderful exploits, by which the Hindus became like atoms of dust scattered in all directions. Their scattered remains cherish, of course, the most inveterate aversion towards all Muslims. This is the reason, too, why Hindu sciences have retired far away from those parts of the country conquered by us, and have fled to places which our hand cannot reach, to Benares and Patna, and other places. And there the antagonism between them and all foreigners receives more and more nourishment both from political and religious sources" (Sachau, 1910). Albiruni was a hostage from Khwarizm and was part of the entourage of Muhammad of Ghazni; he made efforts to learn Sanskrit and meet with Indian scholars whenever he could; he collected Indian manuscripts, and translated some of them. His *India* is full of sympathetic observations about an occupied people and sometimes contains references to his own tragedy. The new invaders were not at all similar to the Caliphs of Baghdad but were more like the Huns in that they too were plundering and taking away what they could; but they came again and invaded farther than the last time, and eventually they started settling to establish their own rule. By about 1300 much of north India, from the river Indus to the river Ganges and to the river Narmada was under Islamic rule. The earlier rulers of Baghdad and Damascus may have been interested

in astronomy, mathematics and scholarship but the invaders of India were deserters from central Asian regimes or descendants of slaves of earlier rulers; establishing of the rule of Islamic law was first and foremost on their agenda. The effect on Indian learning was predictable: preserving what could be preserved became the urgent survival mode.

This had its repercussions on a society which had transmitted its knowledge, sacred and secular, by oral methods. As was mentioned earlier the exigencies of the metre often necessitated the omission of important parts of mathematical formulas, or contributed to the imprecision of technical terminology by forcing the poet to substitute one term for another. This did not matter too much as long as the texts were taught in a school that preserved their interpretation orally, or after a commentary had been published; but when the teaching of the earliest texts ceased and no commentaries were composed, then the texts that were transmitted became corrupt. Only the texts were copied, without comprehension or care, so that often what we have are frequently fragmentary, and often incorrect representatives of the original. Often with such texts one must guess at the problem that is to be solved, invent a solution that seems reasonable within the context of the rest of the work, and then see whether the manuscript readings can somehow be made to coincide with this solution. Even the existence of a commentary, however, does not always provide the reader with an understanding of the text. The commentators themselves are almost never interested in explaining the derivation of the rules; they are more concerned to repeat them in clearer language and to exemplify them. Sometimes they cannot even repeat them correctly. What the commentary does do in all cases, however, is to offer some guarantee of the status of the text in the time of the commentator. Frequently this is a very valuable aid. Presenting mathematics in verse had a subtle and deleterious influence: instead of the bracing precision of the *sutra* some of Bhaskara's verses were in precise but courtly Sanskrit: people went into ecstasies over verses from Bhaskara's *Lilavati* because of its poetry, and not about mathematics. Indian scholarship was to some extent inhibited and handicapped by an insistence to stay too close to the original problems. Indian attitude was to regard mathematics as an auxiliary or feeder subject and not as an autonomous discipline and there was no stimulus from interactions with other areas of knowledge; and further a stimulus from domains of science other than astronomy was lacking.

6) Madhava, Nilakanta (1350 to 1700)

Beginning about 1350 an active community, associated with Madhava, was found to flourish in South India. Over the centuries preceding Madhava the Aryabhata tradition had been preserved in the South; successive revisions of the astronomical

calculations to be consistent with observations had been a continuing activity. As mentioned earlier there is the possibility that this school began with Vararuci in the fourth century, and it is the lack of discovered work between the fourth and the fourteenth centuries that makes it appear as if the Madhava school sprang out of nowhere. As with other mathematical scholarship this school too was interested in astronomy, astrology, calendrical calculations and the careful tabulation of the paths of planets. While they too relied on the traditional paradigms (beginning of an epoch, circular paths of planets, and so on) they were concerned when they found that their calculations did not correspond to observations. When they discovered this, they took steps to change the constants and parameters in their models to bring them in line with the observations, but without giving up the basic paradigms (the power of the received idea).

There was something unique about the nature of the community of scholars in this school. Court as the centre of activity was not the norm. While they did enjoy much royal patronage the patronage seems to have been given in the form of land and estate and over years large tracts of land accrued to the groups of scholars. They lived together, and they continued to do what was required by the court. The transmission of knowledge through the education and upbringing of younger scholars was done by bringing young scholars to live in these communities. Descriptions of the transmission of knowledge from teacher to pupils, the manner in which the pupils lived in *illams* (Tamil word, meaning "house" or better "residence") and the proximity in which different teachers lived all allowed for close contact between not only teacher and student but also between teachers. As the pupils graduated it was not uncommon for some pupils in an *illam* to write a root text, subsequently a commentary and later another text in which additions and improvements were explained. This was a new practice. Before this period authors in India wrote books about all of mathematics, a *summa* as it were. But in this South Indian development there was a departure. We have a series of texts, commentaries, and new texts. These show a concern for mathematical writing in which the author not only repeated what was known but presented it with derivations which were intended to convince the reader; the texts also included new derivations of old results as well as new results which were discovered by the author. They used infinite series, induction, and acceleration of convergence in their geometric derivations for approximating lengths of curves and values for $\pi/4$ (Whish 1835, C. T. Rajagopal 1952, 1978, Gupta 1987, P. Rajagopal, 1993)

Having arrived at the brink of a theory of infinite series, why were these ideas and techniques not pushed forward further to their logical conclusion, ushering in mathematical analysis as it emerged afresh subsequently in Europe? Why did all this activity taper off gradually and eventually get arrested? Some hints

towards answering questions can be figured out. The slackening of the activity of this school may have been due to work along certain directions having got saturated; even in this school mathematics was a feeder subject, providing accurate estimates and methods for the divination, astrology, and calendrical activities. The stimulus from other activities of knowledge was lacking, more so in this school than in many others. Foreign contact may have helped in the dissemination but in South India, while the effects of Islamic invasion did not affect them until after about 1500 the few other foreign contacts were of not much help in bringing new ideas about celestial bodies to them. Another question that arises is: why were all these achievements not disseminated? why did they not have any influence on development of mathematics in India and elsewhere? While Colebrooke's work was widely known that of Whish remained to be revived more than a century later by C. T. Rajagopal.

7) Ramchundra (1650 to 1850)

By the end of the eighteenth century Islamic rule from the Moghal court of Delhi had been virtually replaced by the hegemony of European trading companies. A century later the British Crown took over the administration of the country and India became a colony of the British. During those two centuries mathematical activity was not much more than a desperate effort to preserve what was known. It was subsumed in the larger concern about preventing cultural annihilation. For the new rulers the need to govern India became urgent and there arose need for educating British civil servants. The British instituted India studies in England, and out of that background came scholars who became the re-discoverers of Indian philosophy, astronomy, and sciences. In India they decided to start schools which will teach English and "prepare Indians to think like the British". From such a school in Delhi graduated Ramchundra, educated in the English language, who became a mathematics teacher later on. He was interested in British and European mathematics as well as science; he wrote a number of expository articles on technology and mathematics, including short lives of mathematicians. He taught himself about Indian algebra (through the work of Bhaskara II). He had also learned some Calculus at school, and decided to write about ways in which British Calculus can be grafted on to Indian Algebra (Ramchundra 1850). The English mathematician Augustus de Morgan became interested in the project and got a British edition published in 1859. The books were severely criticised by reviewers both in India and in England. Ramchundra passed into history; his effort to contribute to mathematics had no impact on Indian mathematics (Raina and Habib 1990, Raina 1992).

8) Conclusion and overview (1880 to 1920)

That brings the development to about 1880. British style universities were founded in Madras, Calcutta and Bombay. These

three universities were modeled after London University (a central university and affiliated colleges which delivered the curriculum of that central university). Ramanujan was a student in one such college in Kumbakonam (in Madras Presidency). He failed the examinations in several subjects after the second year (all except mathematics) and since the rules required students to pass in all subjects he left college to find a job. However he came across a book of formulae (Carr 1886) and he went on to derive all of them for himself. He derived many more and some of those were sent to Hardy (of Cambridge) who brought Ramanujan to Cambridge (Kanigel 1991). The theorems and results in that book may be thought of as *sutras* written in pithy and terse verse as Indian verses in Sanskrit mathematics books were. They employed a minimum number of syllables, were unambiguous, pithy, comprehensive, shorn of irrelevancies and were also blemishless. Pupils were to learn them and derive them and use them, sometimes with the help of a teacher. Ramanujan did the same (without the help of a teacher), and presented his results without any proofs or derivations. His "notebooks" continue to leave their expositors figuring out the intermediate steps involved in the intuitive leaps, inductive generalizations and arguments by analogy. In these Ramanujan was following in the footsteps of Aryabhata, Brahmagupta, Bhaskara II and Madhava. With his election to the Fellowship of the Royal Society of London in 1917 he became a symbol for students in Indian universities.

Chronology

	India	Elsewhere
-800	<i>Sulvasutras</i>	
-350	Panini	Euclid
400	<i>Bakshali Manuscript</i>	Hypatia
628	Brahmagupta	
750	Sridhara	
850	Mahavira	al-Khwarizmi
1150	Bhaskara II	1202 <i>Liber Abaci</i>
1356	Narayana	Bradwardine
1340	Madhava	
1444	Nilakanta	1560 Cardano
1650	Narayana	Kepler, Newton
1818	Colebrooke	1790 Lagrange
1835	Whish	1800 Gauss
1850	Ramchundra	
1917	Ramanujan	

Bibliography

Carr. G. S. (1886), *A Synopsis of Elementary Results in Pure and Applied Mathematics*; Reprinted as *Formulas and Theorems in Pure Mathematics* (New York: Chelsea Publishin Co, 1970)

- Colebrooke. H. T. (1817), *Algebra, with Arithmetic and Mensuration, from the Sanscrit of Brahmegeuta and Bhascara*, pp. xxv - xxvii (London, John Murray; Vaduz, Liechtenstein: Saendig Reprint Verlag, 1972)
- Datta. B (1932, 1993), *Ancient Hindu Geometry, the Science of the Sulba* (Cosmo Publications, New Delhi; reprint of a book published in 1932)
- Hayashi. T. (1985) "The Bakshali Manuscript", Dissertation for the Ph. D. degree, Brown University.
- Hoernle. R. (1887), *On the Bakshali Manuscript* (Alfred Holder, Vienna)
- Ingalls. D. H. H. (1951), *Materials for the Study of Navya-nyaya Logic* (Harvard: Oriental Series, Vol. 40; reprinted in 1988 by Motilal Banarsidas, New Delhi)
- Kanigel. R. (1991) *The Man who knew Infinity* (New York: Simon and Schuster)
- Kay. G. R. (1927), *The Bakshali Manuscript; A Study in Medieval Mathematics* (Archaeological Survey of India report; Cosmo Publications, New Delhi; 1981 reprint)
- Maanikka. E. (1985) *Angkor Wat: Meaning Through Measurement* (Dissertation for the Ph. D. Degree, University of Michigan, Ann Arbor)
- Pingree, David (1981), *Jyotihsastra*, (Wiesbaden: Otto Harrassowitz)
- Raina. D. and Habib, S. I. (1990) "Ramchandra's Treatise through 'The Haze of the Golden Sunset': An Aborted Pedagogy", Social Studies in Science, Vol. 20, pp. 455-472
- Raina. D. (1992) "Mathematical Foundations of a Cultural Project or Ramchandra's Treatise 'Through the Unsentimentalised Light of Mathematics' " Historia Mathematica Vol. 19, pp. 371-84
- Rajagopal. C. T. (1952), "A Hindu approximation to Pi", Scripta Mathematica, Vol. 18, pp. 25-30
- Rajagopal. C. T. and Rangachari. M. S. (1978), "On an Untapped Source of Medieval Keralese Mathematics", Arch. H. E. S., Vol. 18, pp. 89-102
- Rajagopal. P. (1991), "The *Sthaanangasutra* Programme in Indian Mathematics", Arhat Vachana, Vol 3, No. 2, pp. 1-8
- Rajagopal. P. (1993), "Mathematical Problem-Solving in Medieval

- India and Europe", *Arhat Vachana* Vol. 5, No. 3, pp. 77-92
- Rajagopal. P. (1992) "Practical and Commercial Problems in Indian Mathematics", *Arhat Vachana*, Vol 4, No. 1, pp. 55-70
- Rajagopal. P. (1993), "Infinite Series in South Indian Mathematics", Proceedings of the Canadian Society for the History and Philosophy of Mathematics, Ottawa)
- Rajagopal, P. (1994) "Indian mathematics after the 15th century", Proceedings of the Canadian Society for the History and Philosophy of Mathematics, Calgary.
- Rajagopal. P. (1995) "Proofs in Indian Mathematics", Proceedings of the Canadian Society for the History and Philosophy of Mathematics, Montreal [revised version submitted to Indian Journal for the History of Science]
- Ramchundra (1850, 1859), *A Treatise on Problems of Maxima and Minima Solved by Algebra* (Calcutta; reprinted by Wm. H. Allen, London)
- Rangacharya. M. (1912), *The Ganitasarasangraha of Mahavira* (Government Press, Madras)
- Sachau. S. C. (1910) *Albiruni's India* (Delhi: Low Price Publications; reprinted in 1989)
- Saraswati Amma, T. A. (1979), *Geometry in Ancient and Medieval India* (Delhi: Motilal Banarsidass)
- Sarma. K. V. (1972) *A History of the Kerala School of Hindu Astronomy* (Hoshiarpur: Vishveshwaranand Institute)
- Seidenberg. A. (1983), "The Geometry of the Vedic Rituals" (in F. Staal, ed., *Agni: the Vedic Ritual of the Fire Altar*, Vol II, pp. 95-126)
- Sen. S. N. and Bag. A. K. (1983), *The Sulbasutras, with Text, English Translation and Commentary* (Indian National Science Academy, New Delhi)
- Shukla. K. S. (1976), *The Aryabhatiya of Aryabhata* (Indian National Science Academy, New Delhi)
- Srinivasaiengar. C. N. (1967), *The History of Ancient Indian Mathematics* (World Press Private Ltd, Calcutta)
- Staal. F. (1965) "Euclid and Panini", *Philosophy East and West*, Vol. 15, pp. 99-116 (Reprinted in "Universals", Studies in Indian Logic and Linguistics, University of Chicago Press, 1988)

Thibaut. G. (1875, 1984), *Mathematics in the Making in Ancient India* (K. P. Bagchi, Calcutta; reprint of *On the Sulbasutras* published in the Journal of the Royal Asiatic Society of Bengal)

Whish. C. M. (1835), On the Hindu Quadrature of the Circle, and the Infinite Series of the Proportion of the Circumference to the Diameter Exhibited in the Four Sastras, the *Tantra Sangraham*, *Yukti Bhasha*, *Carana Paddhati* and *Sadratnamala*, by Charles M. Whish, of the Honourable East-India Company's Civil Service on the Madras Establishment (Communicated by the Madras Literary Society and Auxiliary Royal Asiatic Society), Read the 15th of December 1832, Transactions of the Royal Asiatic Society of Great Britain and Ireland, Vol. 3, pp. 509-523

A CULTURA MATEMÁTICA ENCONTRADA PELOS COLONIZADORES NAS AMÉRICA DO SUL E CENTRAL

Eduardo Sebastiani Ferreira

IMECC-Unicamp -Brasil

INTRODUÇÃO

Os estudos das ciências dos Ameríndios é sem duvida um dos assuntos mais apaixonantes, isto tanto para os investigadores como para os alunos. O confronto de culturas sempre acarreta um desequilíbrio em ambas, mesmo que uma delas se coloque como dominadora, há uma troca de saberes que leva a uma ruptura de algo estabelecido, isto é assim hoje quando nos deparamos com as culturas indígenas brasileiras, e foi também na época da chegada dos europeus às Americas. Hoje não se fala mais em descoberta do continente americano mas do encontro de culturas: "A opinião crítica mundial, militante ou acadêmica, rejeita hoje a 'descoberta' em favor do termo 'encontro'. Encontro de dois mundos, pondo em cena, face ao europeu, o universo cultural indígena. Falar de encontro significa reconhecer a densidade histórica das culturas que habitavam o continente, em sua multiplicidade e complexidade: 133 famílias lingüísticas, um número incontável de línguas e dialetos específicos.

Na idéia do 'encontro' há também o reconhecimento da extraordinária vitalidade da região atualmente chamada de América Nuclear: México, Andes

Centrais, parte da América Central e Caraíbas. Zonas que concentravam perto de 80% da população continental- desenvolvendo, no México e no Peru, uma agricultura de rendimento elevadíssimo-, cidades portentosas, Estados organizados. Mas quando falamos em México e Peru não devemos nos restringir, como é usual, aos casos mais conhecidos - astecas, maias e incas -, que foram os últimos impérios nessas regiões."(Vainfas R. O ENCONTRO DE DOIS MUNDOS - Ciência Hoje vol 15 n.86-1992 p.7)

Este encontro deve ter acarretado um enorme impacto a ambas culturas, tanto para o habitantes do Novo Mundo como aos Europeus, pois para estes também grandes mudanças ocorriam em seu continente:" Na Europa, o mundo moderno começava a surgir. Naquele ano de 1507, em que os mexicanos, mais uma vez, 'ligavam os anos' acendendo o Fogo novo no cimo da montanha de Uixachtecatl, Lutero acaba de ser ordenado padre. Um ano antes, Leonardo da Vinci havia completado *A Gioconda*, e Bramante iniciara a construção da Igreja de São Pedro, em Roma. A França está empenhada em grandes guerras na Itália; em

Florença, Maquiavel torna-se secretário de Estado de Milícia. A Espanha reconquista seu solo, derrotando os mouros de Granada; uma febre de expansão arrasta suas caravelas, seus guerreiros e seus missionários para as terras recém-descobertas. Mas seu ímpeto não foi ainda além das ilhas: Bahamas, Cuba, Haiti. Na costa do Yucatán e no golfo do México há grandes extensões de terras com suas cidades formigantes de gente, suas guerras, seus Estados e seus templos”(Soustelle,p.12)

Mesmo tudo isto ocorrendo no século XVI e mesmo depois com a colonização dos séculos XVII e XVIII, e ainda com os trabalhos dos arqueólogos, ainda pouco se sabe destas culturas americanas. Temos algum conhecimento proveniente dos relatos dos europeus e mesmo dos habitantes desta região, que depois de terem aprendido o espanhol, escreveram relatos de fatos históricos de seus povos. Infelizmente não temos nenhum livro(códex) sobre o conhecimento matemático dos Maias e dos Astecas, estes livros trazem divinhações, tabelas astronômicas e alguns fatos históricos. Dos Incas ainda temos muito menos, pois eles não tinham escrita, o mesmo ocorrendo com os outros povos do continente americano. O pouco que temos destes povos são os sistemas de numerações, que por si só é um estudo fascinante, marcador de quantidades e alguns ábacos. Mesmo assim o estudo deste material é rico em conhecimento matemático, pois nos mostra uma ciência em construção e que não há somente uma matemática, que veio a nos pelo Ocidente. A relação com este conhecimento leva os alunos a terem uma outra visão da matemática, além é claro pelo próprio fascínio de uma matemática de civilizações diferentes culturalmente da nossa.

MAIAS

“De todas as culturas precolombianas da América central, a civilização Maia é sem nenhuma dúvida a mais prestigiosa. E a influência que ela exerceu sobre as outras - notadamente sobre os Astecas- foi comparada à dos Gregos sobre os Romanos durante a antigüidade”(Ifrah,p.691)

Esta extraordinária civilização teve seu início antes de nossa era, isto pelos estudos arqueológicos ,mas seu apogeu se deu nos séculos IX e X. A região ocupada pelos Maias foi a península de Yucatã e sul do México, partes da Guatemala, Honduras e uma seção ocidental de Salvador. Os Maias possuíam uma escrita em forma de glifos (caracteres picturais gravados, esculpido ou pintados),que segundos os estudiosos chegou mesmo a representar o fonético, e que até hoje ainda não esta totalmente decifrada.É também um fator de estudo até hoje o motivo do desaparecimento desta civilização: ”Os Maias abandonaram progressivamente seus centros rituais como também suas cidades e a região central

do 'Antigo Império'. Em certos casos o abandono foi tão brusco que os prédios em via de construção restaram inacabados. Muito tempo acreditou-se que se produziu um êxodo de toda a população, mas as escavações recentes mostraram a inexatidão desta teoria. Durante estes cinquenta últimos anos, uma multiplicidade de hipóteses foram colocadas para explicar este pretendido êxodo do conjunto da população para o norte e o sul, notadamente as epidemias, tremores de terra, condições atmosféricas, as invasões; ou mesmo chegaram a pensar que uma interpretação da vontade dos deuses maias pelos sacerdotes podia ser a causa"(Ifrah,p.701)

Os monumentos e os códices(uma espécie de livro) são as principais fontes que dispomos para o conhecimento da ciência maia. Infelizmente destes códices somente três existem hoje: o de Dresde, o de Madri e o de Paris, cidades onde se encontram. Mas eles tratam de astronomia, onde os Maias tinham um alto conhecimento pela época e pela não existência em sua sociedade de instrumentos próprios, os Maias não conheciam o vidro; os códices falam também de divinhações, de rituais e cerimônias. Davam grande importância a marcação do tempo, tinham dois tipos de: tempo ritual e tempo solar, e por isto tinham dois calendários o *Tzolkin*, de caráter essencialmente religioso; e o *Haab*, que era um calendário solar. O primeiro se compunha de vinte ciclos de treze dias e contava assim com duzentos e sessenta dias, e o solar tinha dezoito períodos de vinte dias e um complementar de cinco.

Esta necessidade de marcar o tempo fez com que o sistema de numeração Maia apareça em quase todos os monumentos, sistema este posicional, de base vinte, e com símbolo para o zero. A escrita era no sentido vertical e de baixo para cima, a unidade representada por um ponto, cinco unidades por um traço e o zero por um símbolo que lembra uma concha. Então na posição mais baixa os números iam então até dezenove, na posição logo acima de vinte e aqui aparece uma irregularidade explicável pelo calendário de 360 dias, os números vão até 359, um ponto na terceira posição então representa o número 360. Depois segue como um sistema de base vinte.

1	• ou	11	≡ ou •
2	•• ou :	12	≡ ou •
3	••• ou :	13	≡ ou •
4	•••• ou :	14	≡ ou •
5	— ou	15	≡ ou •
6	—• ou •	16	≡ ou •
7	—•• ou •	17	≡ ou •
8	—••• ou •	18	≡ ou •
9	—•••• ou •	19	≡ ou •
10	≡ ou		

(figuras 1)

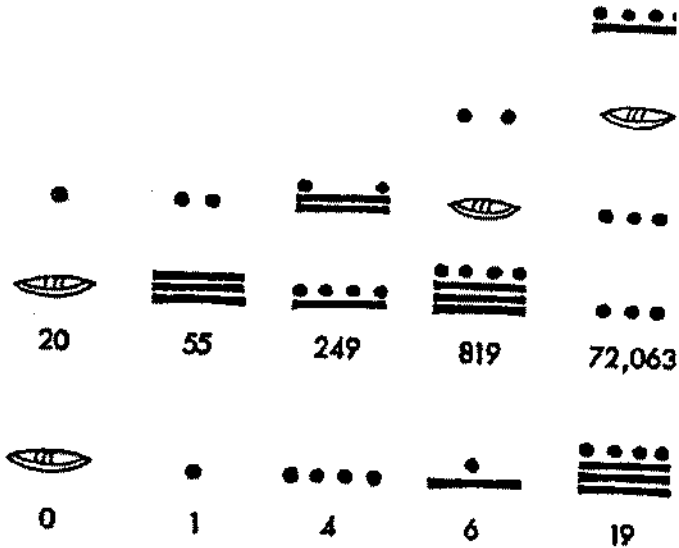

(figura 2)

Algumas vezes os números aparecem também verticalmente quando estão ao lado do período mensal a que se referem.(figura 3)

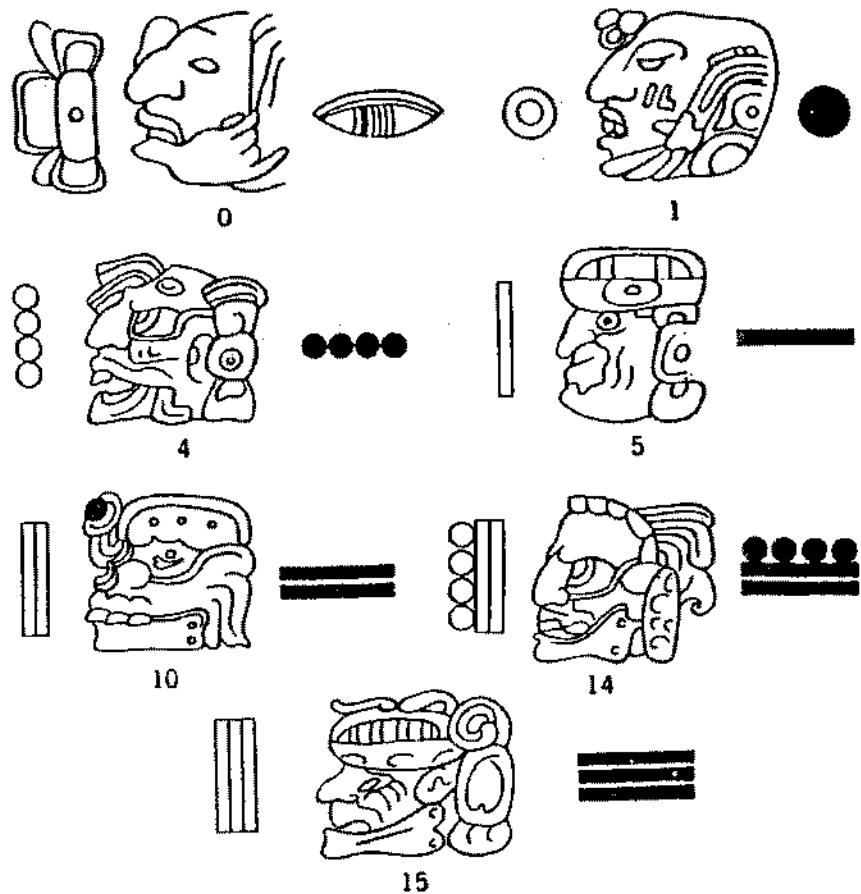

(figura 3)

“De fato as únicas menções numéricas que possuímos da civilização Maia se referem não a aritmética prática, mas a astronomia e ao contar o tempo.”(Ifrah,p.723)

ATIVIDADES

Há alguns artigos que sugerem algumas atividades aritméticas maias, Bidwel, Richeson, Aldana, etc. Baseado nestas propostas podemos trabalhar em sala de aula com a aritmética maia, que acredito deva despertar um grande interesse nos alunos.

Usando uma folha de papel com uma coluna dividida em 3 ou 4 partes, dependendo dos números que queremos trabalhar(figura 4), e usando botões para designar os pontos, palitos para os traços e conchas podemos escrever os números. Para facilitar o trabalho, e é como aparece na maioria das propostas, trabalhar com toda base 20, isto é o ponto na terceira posição representando 400. Trabalhando as quatro operações podemos perceber como é rico este material. Na multiplicação pode-se perceber a necessidade de uma tabela com somente sete partes, isto é dos

pontos de um até quatro e dos traços de um a três traços, e usando a decomposição dos números e a propriedade distributiva da multiplicação.(figura 5)

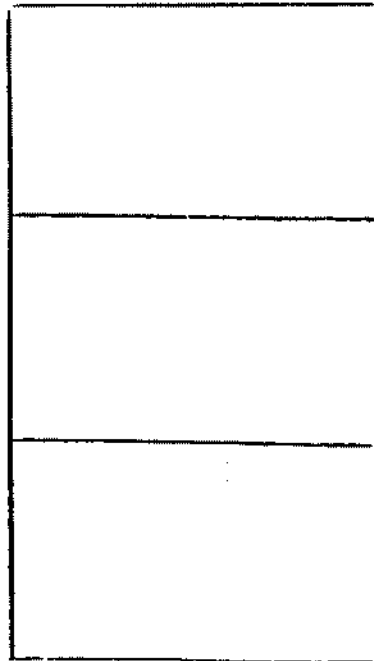

(figura 4)

×	—	==	===
.	—	==	===
..	—	...	==	⊖	.
...	...	—	==	==	..
....	==	...	⊖	⊖	...
—	—	==	==	⊖
==	==	⊖	.	⊖	..	⊖	..
===	===	.	..	⊖

(figura 5)





ASTECAS

Foi com enorme espanto que os homens de Castela encontraram ao lado do Golfo do México uma civilização com cidades ultra povoadas, grandes templos, um comércio grande e muito rica. Eram os Astecas, que autodenominavam Mexicanos. "Os Astecas ou Mexicanos dominavam com esplendor a maior parte do México quando os conquistadores espanhóis ali penetraram em 1519. Sua língua, sua religião se impunham, do Atlântico ao Pacífico" (Ilfrah, p.706) Possuíam também como os Maias uma escrita glifada, que representava figurativamente os objetos: "A escrita figurativa dos antigos Mexicanos constituía, pelo menos na época da chegada dos conquistadores espanhóis, de uma sorte de compromisso entre um sistema ideográfico e uma notação fonética, certos caracteres mais ou menos realistas designavam os seres, os objetos ou as idéias, e outros (ou os mesmos) notavam sons.

Esta escrita- que os Astecas herdaram dos povos do Antigo Mundo- nos é conhecida por alguns manuscritos mexicanos redigidos antes ou após a conquista espanhola. Destes documentos, certos tratam de seitas religiosas e rituais, de divinhações e magia; outros relatam os acontecimentos míticos ou históricos (migrações das tribos, fundações das cidades, origem e história das dinastias). Outros em fim constituem os registros dos enormes tributos em material precioso, em cereais e homens que os funcionários imperiais coletavam nas cidades a serviço, para a conta dos notáveis de Tenochtitlan (capital do império)" (Ilfrah, p.710).

Possuíam os Astecas também códexis como os Maias e destes o mais conhecido é o Códex Mendoza: "Sua importância particular, é necessário sublinhar, revela do fato que ele é acompanhado de um comentário sobre a significação de cada um de seus detalhes, ou quase, comentário redigido em espanhol por um contemporâneo, segundo as explicações dos astecas eles mesmos" (Ross apud Ilfrah, p.710).

Quanto a numeração asteca era de base 20- a unidade representada por um ponto ou círculo, o vinte por um machado, o quatrocentos por uma pluma e o número 8.000 por um desenho que representa uma bolsa. (figura 6)

○ ou ●			 ou 
1	20	400	8 000

(figura 6)

Podemos ver em algumas figuras que aparecem nos códices como por exemplo as de 20 brincos, 100 sacos de semente de cacau e 200 potes de mel (figura 7).

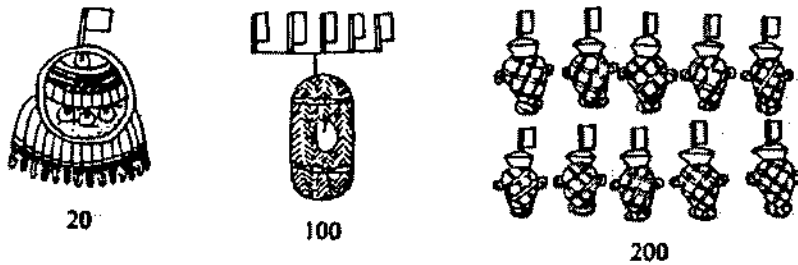

(figura 7)

Ou ainda outras como 400 mantas decoradas, 800 peles de veados e 1600 cestos de semente de cacau. (figura 8)

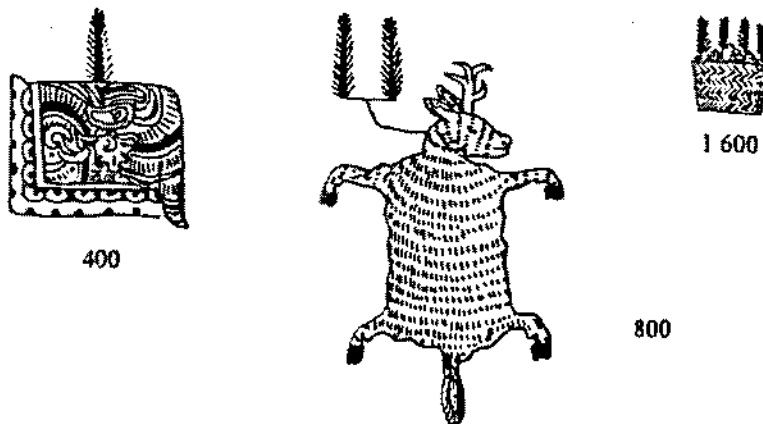

(figura 8)

Atividades

Podemos solicitar aos alunos que escrevam quantidades de coisa por eles conhecidas na escrita asteca, exemplo: 200 lápis, 800 balas, 20 borrachas, etc. Não vejo como ir além na aritmética asteca, fazer as operações seria somente um ajuntar de quantidades e talvez mudar símbolos, nada além disto.

INCAS

Esta outra civilização que habitou o continente Americano, e que tem até hoje alguns descendentes em vários povoados da América do Sul, foram os Incas, também povos que espantaram os colonizadores pelas suas construções, suas estradas e principalmente pela riqueza: "Assim como os maias e os astecas, também os incas eram herdeiros de uma cultura milenar. Seu derradeiro desenvolvimento político e econômico curiosamente coincide no tempo também com esplendor dos astecas, o outro 'Povo do Sol'".

Pouco antes da morte do inca Huayna Cápac, pai de Huáscar e Atahualpa, ocorrida por volta de 1525, seus domínios, com cerca de um milhão de quilômetros quadrados, se estendiam desde a fronteira da atual Colômbia até partes do norte do Chile e da atual República Argentina. De um extremo a outro havia cerca de quatro mil quilômetros, em grande parte interligados pelos famosos 'caminos del incaro'."(León-Portilla,p.87)

Os Incas não possuíam escrita e portanto o que temos de relato deste povo é pelos comentaristas da época, muitos deles feito pelos próprios índios, que depois de aprenderem o espanhol relatavam histórias de seu povo. É assim que um dos mais importantes documentos de relato inca é de Felipe Guamán Poma de Ayala, que com seus relatos e principalmente os desenhos nos dá uma amostra significativa da sociedade inca no século XVI.(figura 9)



(figura 9)

Um dos artefatos mais importante dos Incas é sem dúvida o *quipu*, feito de cordas coloridas nas quais os nós representavam quantidades e as cores as respectivas famílias ou cidades. Há vários trabalhos importantes sobre os quipus com por exemplo os artigos de M. Ascher, Cossio, Exploratorium, etc.

Os quipus serviam para marcar quantidades. Há uma teoria hoje que eles também eram uma forma de escrita inca.(figura 10)Para o cálculo de quantidades, dizem os historiadores, que eles se serviam de uma espécie de ábaco que aparece no desenho de Ayala. Este ábaco hoje chamado de *yupana* é hoje estudado, e tem várias teorias de como era utilizado,(ref: Glynn, Acevado, etc.)

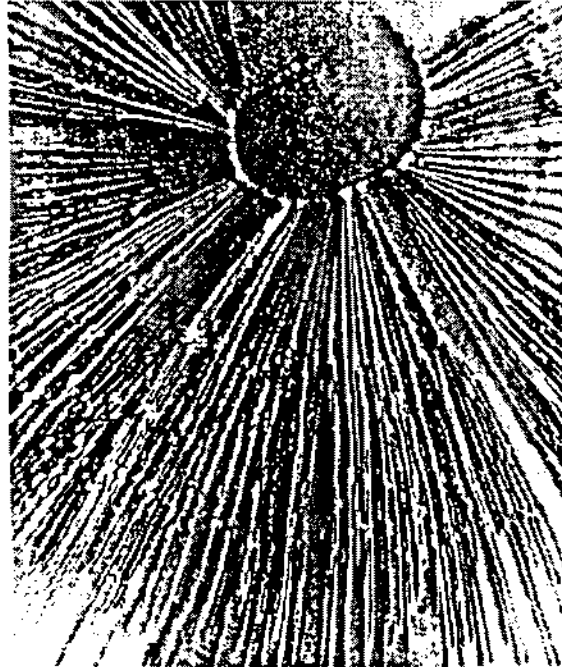

(figura 10)

Outro aparente ábaco inca que também despertou o interesse dos estudiosos é o que hoje se denomina *Taptana* (Butsch, Caleno e Muenala).

ATIVIDADES

Aqui várias atividades se pode fazer com estes artefatos incas, pôr exemplo um quipu simplificado com 3 cordas de cores diferentes, onde cada cor representa unidade, dezena e centena; podemos assim marcar quantidades até 999. Usei este quipus com crianças de sete anos, que estavam aprendendo nosso sistema de numeração decimal e pela professora foi um marco na aprendizagem deles, pois depois do quipu entenderam a numeração posicional.

Outra atividade é a utilização do Yupana para operar quantidades, como ábaco. Há vários trabalhos com sugestões sobre como utilizar a Yupana, por exemplo Glynn, Cossion, Acevedo, etc. A professora Marta Villavicenco faz um trabalho muito bonito com o Yupana no Peru, com crianças quechuas.(figura 11)

○ ○ ○ ○ ○	○ ○ ○ ○ ○	○ ○ ○ ○ ○	○ ○ ○ ○ ○	○ ○ ○ ○ ○
○ ○ ○	○ ○ ○	○ ○ ○	○ ○ ○	○ ○ ○
○ ○	○ ○	○ ○	○ ○	○ ○
○	○	○	○	○

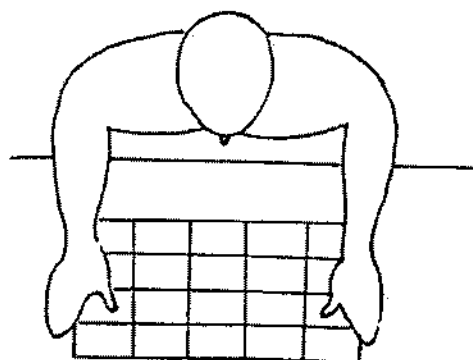

(figura 11) Yupana

Quanto o Taptana há os trabalhos de Butsch, Caleno e Muenala com algumas maneiras de se utilizar este instrumento como ábaco. Também já se utiliza em algumas escolas quechuas.(figuras 12)

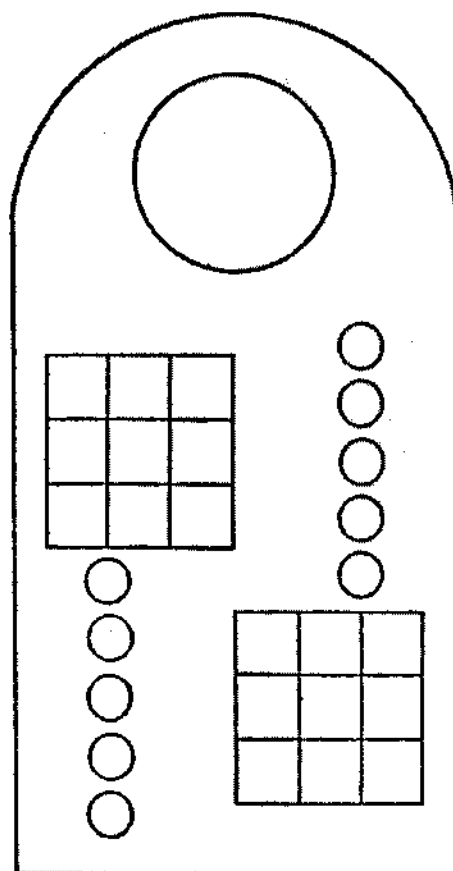

Elaborado en el CIEI

(figura 12) Taptana

Pode-se operar também com estes dois ábacos, num processo simples de ajuntar ou tirar para soma e subtração. Quanto a multiplicação e divisão eu não vejo outra maneira senão o de somas e subtrações sucessivas.

ÍNDIOS BRASILEIROS

Não há uma estimativa precisa da população indígena brasileira na época da colonização: "Não existem números precisos, mas há estimativa indicando que a população nativa do continente chegava, à época da conquista, a mais de cinquenta

e três milhões de pessoas, sendo que só a bacia Amazônica teria mais de cinco milhões e seiscentos mil habitantes”.(Denevan apud Neves,p.174). Estas estimativas dão também a quantia de mais de mil etnias. Hoje no Brasil temos aproximadamente 250.000 índios, e cerca de 150 etnias.

O que temos como fontes documentais destes povos na época da conquista são relatos de viajantes da época ou tradições orais e mitológicas, nenhuma tribo brasileira possui escrita. ”Não é inútil lembrar que entre os povos pré-colombianos do Novo Mundo, os da Meso-América (região que se estende do México à Guatemala e à Honduras) parecem terem sido os únicos a terem uma verdadeira escrita.”(Ifrah,p.711) .Então quando se quer falar da matemática dos índios brasileiros no início do século XVI, fala-se na matemática encontrada hoje nas diferentes tribos, mesmo sabendo que :”Face à ruptura demográfica e social promovida pela conquista, foi sugerido que os padrões de organização social e de manejo dos recursos naturais das populações indígenas que atualmente ocupam o território brasileiro não seriam representativos dos padrões das sociedades pré-coloniais.” (Roosevet apud Neves, p.175). Nos documentos que dispomos desta época temos alguns relatos como: *O Selvagem* do General Couto de Magalhães e *Os Indígenas do Nordeste* de Estevão Pinto e outros que nos dão algumas descrições de certas tribos e seus sistemas orais de numeração.

O trabalho etnográfico que hoje se faz com algumas tribos brasileiras tem um material matemático mais rico, além dos números temos também trabalhos de classificação simétrica dos ornamentos e das pinturas corporais, medidas de comprimento e área, conceitos geométricos, etc.

Pela riqueza do artesanato destes índios pode-se perceber que têm vários conceitos geométricos incorporados na sua cultura, como por exemplo: simetria como estética, paralelismo, perpendicularismo, ângulo, figuras geométricas planas, etc. Quanto a numeração os índios brasileiros contam muito pouco, não há necessidade de contagem muito grande no dia-a-dia de uma aldeia, assim a maioria deles contam até quatro ou cinco, dos que conheço somente os Palikur do Maranhão contam até vinte.

Atividades

Mostrar algumas numerações dos índios brasileiros, ressaltando que alguns usam o processo aditivo para numerar, como por exemplo:

Yawanawá:

I-Weste

- 2-Hawe
- 3-Hawe-weste (2+1)
- 4-Hawe-hawe (2+2)
- 5-Hawe-hawe-weste (2+2+1),

Kaxinawá:

- 1-Bestixai
- 2-Dabe
- 3-Besti-dabe (ou dabe-inu-besti) (1+2 ou 2+1)
- 4-Dabe-inu-dabe (2+2)
- 5-Melã-besti

Tapirapé:

- 1- Áxepe
- 2-Mokõj
- 3-Maãput
- 4-Xairõ

Nestes três exemplos a contagem vai até 4 ou 5 e depois se diz muito.

Uma classificação de simetrias usadas nas pinturas corporais ou em cestarias também desperta algum interesse nos alunos.(figura 13)

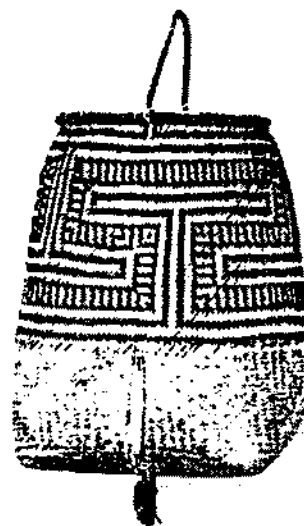
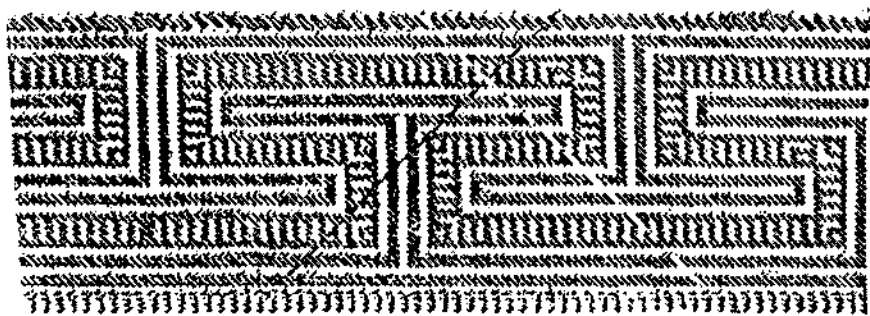

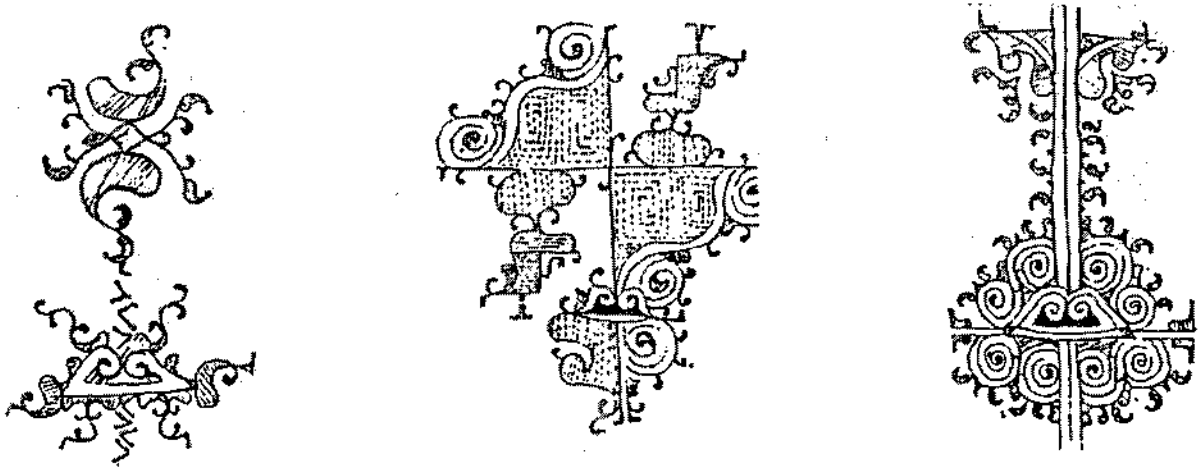
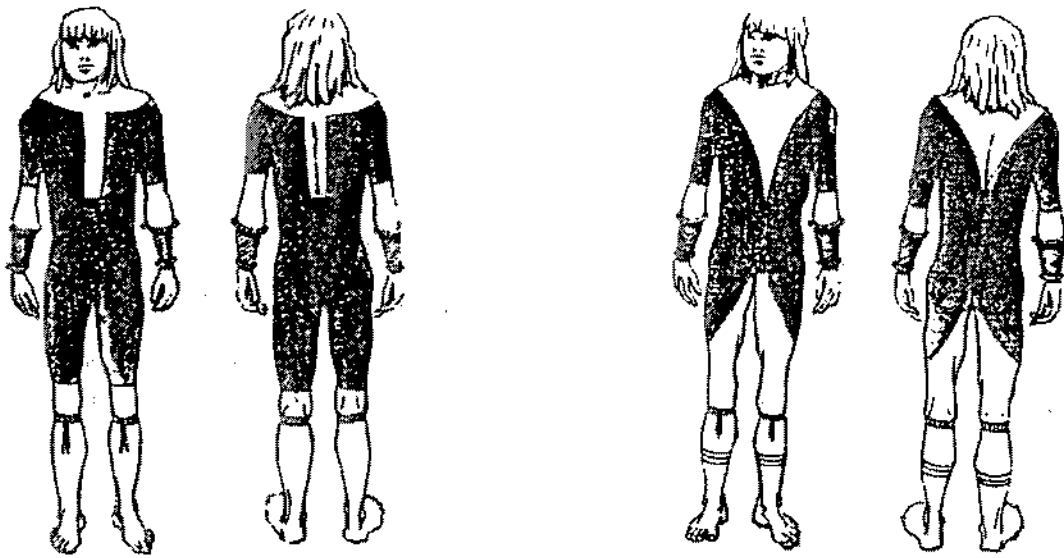

(figura 13)
 Marcador de quantidade somente conheço o das mulheres Trumai do Parque do Xingu que é o simples dar nós em cordas .Há também o Katyba dos Waimiri-

Atroari do Amazonas que é um marcador de tempo para as festas, que também desperta interesse em crianças como já tive a oportunidade de presenciar.

CONCLUSÃO

Acredito que um estudo da matemática destes povos pode colaborar na sala de aula de matemática por vários motivos, além do próprio interesse do assunto e pela curiosidade que desperta, creio que o mais importante é os alunos perceberem que a matemática não é única, a que chegou até nos pelo ocidente, mas cada povo constrói seus conhecimentos matemáticos conforme suas necessidades sociais, isto é a matemática não é uma ciência pronta, mas sempre em construção, construção esta feita pelo homem com toda imperfeição que isto acarreta.

BIBLIOGRAFIA

Acevedo, C.-La Yupana incaica. Elemento histórico como instrumento pedagógico.

Proc. do HPM (1994) p.75-87

Aldana, L. -Aritmética Maya. Propuesta Metodológica

Proc. do HPM (1944) p.118-128

Ascher, M. e Ascher, R.- Numbers and Relations from Ancient Andean Quipus

Archive for Hist. of Ex, Sciences 8(4) (1972)p.288-320

Ascher, M.- Etnomathematics

Cole Pub. Comp.(1991)

Bassanezi, R. e Faria, M.- A gramática dos ornamentos e a cultura Arica

Relatório Técnico IMECC UNICAMP 8 (1987)

Bidwell, J.- Maya Arithmetic

The Mathematics Teacher nov.(1967)p.762-768

Butsch, G. ,Caleno, V. e Muenala, H. -El Contador Indígena (Taptana)

Informe del P.EBI n.46 (1992)

Coe, M.- The Maya

Penguin Books (1966)

Cossio, C. - Elementos de Analisis Quichua en Matemática

Copia poli -copiada

Exploratorium - Quipu Meking and Deciphering

Exploratorium Multicultural Sanckbook (1989)

Ferreira, M.- Quando $1+1\neq 2$. Praticas Matemáticas no Parque Indígena do Xingu

Revista Cadernos de Campo n.3(1993)

Glynn, W.- La tapla de cálculo de los Incas

Boletim de Lima

Ifrah, G.- Histoire Universelle des Chifres

Robert Laffont vol.I (1994)

Morley, S. - An introduction the study of Maya hieroglyphs

Dover (1975)

Neves. E- Os índios antes de Cabral: Arqueologia e História indígena no Brasil

A temática indígena na escola (1995)p.171-189

Richeson, A.- The number System of Maya

Ame. Math, Monthly vol. XL (1933) p. 542-546

Saguiet, R. - La Numeracion en Guarani

Ameríndia n.11 (1986) p.145-164

Silva, A. e Gupioni, L.- A temática indígena na escola

MEC-UNESCO (1995)

Soustelle, J. - Os Astecas na véspera da conquista espanhola
Companhia das Letras (1955)

Vainfas, R. O encontro de dois Mundos
Ciência Hoje vol.15, n.86 (1992)

**Weaner, M.- The Aztecs, Mayas and their predecessors-Archeology of
Mesoamerica**
Academic Press (1981)

ALGUMAS NOTAS SOBRE A HISTÓRIA DA MATEMÁTICA EM PORTUGAL

António Leal Duarte, Jaime Carvalho e Silva, João Filipe Queiró
Departamento de Matemática - Universidade de Coimbra, Portugal

Nos últimos oito a dez anos, e na sequência do entusiasmo que acompanhou as comemorações do 200^o aniversário da morte de José Anastácio da Cunha, tem-se observado um interesse crescente pelo estudo da História da Matemática em Portugal. Esse interesse traduziu-se na realização de alguns colóquios temáticos, na publicação de trabalhos de índole vária e sobretudo na criação de um Seminário Nacional de História da Matemática, que tem reunido com periodicidade aproximadamente anual (a 7^a reunião teve lugar em Coimbra em Novembro de 1995).

Nesta conferência procede-se a um brevíssimo sumário dos três grandes períodos em que se pode dividir a História da Matemática em Portugal, com ênfase em pontos que têm merecido, e devem continuar a merecer, a atenção dos matemáticos portugueses interessados nestas questões, concluindo-se com alguns comentários sobre a nossa historiografia da Matemática.

1. A Matemática em Portugal antes de 1772 (João Filipe Queiró)

Neste período, e aliás em toda a História da Matemática portuguesa, destaca-se em primeiríssimo plano a figura de Pedro Nunes (1502-1578), o primeiro ocupante da nova cadeira de Matemática da Universidade, após a transferência definitiva desta para Coimbra. Os seus livros têm sido analisados e comentados, por autores nacionais e estrangeiros, e, sem prejuízo da necessidade de estudos e investigações adicionais, é hoje possível ter uma ideia da importância e do significado da obra do grande matemático português.

Destacamos a seguir algumas obras de Pedro Nunes:

1) Numa sucessão de estudos, culminando no *De arte atque ratione navigandi* (*Opera*, Basileia, 1566), Pedro Nunes, na sequência de uma pergunta de Martim Afonso de Sousa regressado de uma viagem ao Brasil, esclareceu que as linhas de rumo — isto é, as rotas seguidas quando se mantém constante o ângulo com a agulha magnética — não são geodésicas (arcos de círculos máximos) e compreendeu a sua verdadeira natureza: com excepção de casos triviais (os meridianos e os paralelos) em que são circulares, as linhas de rumo são curvas em espiral que se aproximam dos pólos dando um número infinito de voltas em redor deles. Num dos estudos em que tratou das linhas de rumo, o *Tratado em defensam da carta de marear* (Lisboa, 1537), Pedro Nunes enuncia duas propriedades desejáveis para os mapas: a de preservação de ângulos, e a representação de linhas de rumo por linhas rectas. Estes requisitos são exactamente o que tornou o grande mapa do mundo de

Mercator (1569) tão útil na navegação. Uma eventual inspiração de Mercator em Pedro Nunes permanece matéria de controvérsia.

2) A obra *De erratis Orontii Finæi* (Coimbra, 1546, Basileia 1592) contém uma lista de severas correcções de Pedro Nunes a dois trabalhos do matemático francês Oronce Fine (1494-1555). Nesses trabalhos o matemático francês expunha "soluções" para vários problemas clássicos, incluindo a duplicação do cubo, a quadratura do círculo, a construção de polígonos regulares (todas questões só completamente esclarecidas no século XIX) e mesmo a determinação da longitude. Esta obra de Pedro Nunes está actualmente a ser objecto de pormenorizada análise por Anabela Simões Ramos.

3) Uma das obras maiores de Pedro Nunes é o *Libro de Algebra en Arithmetica y Geometria* (Antuérpia, 1567), que redigiu em espanhol. Desta obra se ocupou longamente um especialista na história da Álgebra quinhentista, H. Bosmans. O assunto central é a resolução de equações, sobretudo do 1º grau ao 3º. Traço distintivo são a abstracção e generalidade com que são tratadas as teorias e apresentados os problemas. Pela primeira vez aparecem demonstrações algébricas gerais rigorosas. Pedro Nunes adopta a notação literal, e os raciocínios com letras são independentes de considerações geométricas. São estudadas as operações com polinómios. Importante obra de transição antes de Viète (Bosmans diz de Pedro Nunes que foi "um dos algebristas mais eminentes do século XVI"), o *Libro de Algebra* foi muito conhecido e citado na Europa (entre outros por Wallis). Teve traduções em latim e francês, que ficaram manuscritas.

4) No livro *De Crepusculis* (Lisboa, 1542; Coimbra, 1571; Basileia, 1573) analisou Pedro Nunes, agora em resposta a uma pergunta do príncipe D. Henrique — o futuro Cardeal-Rei —, "a extensão do crepúsculo em diferentes climas". Entre outros resultados, determinou a data e a duração do crepúsculo mínimo para cada lugar no globo. Este problema ocupou os irmãos Bernoulli século e meio mais tarde. Gomes Teixeira faz interessantes observações comparativas dos métodos usados pelo português e pelos irmãos suíços. O *De Crepusculis* foi por vários comentadores considerado a obra-prima de Pedro Nunes, e merece bem uma reanálise moderna.⁽⁴⁾ Ao mencionar as repercussões da obra na Europa, incluindo o aplauso de Tycho Brahe e as citações que dela faz Clavius, diz Joaquim de Carvalho que ela "logrou a consagração inerente às explicações científicas, entrando e fluindo, muitas vezes anonimamente, no caudal dos conhecimentos exactos que constituem património da Humanidade" (*Anotações ao De Crepusculis*, «Obras de Pedro Nunes», vol. II, Lisboa, 1943). Esta apreciação é adequada também ao *Libro de Algebra* e, na verdade, a toda a obra matemática de Pedro Nunes.

Pedro Nunes é o nosso primeiro exemplo de cientista "puro", para quem as exigências de precisão e rigor são uma constante. (A este respeito, é interessante referir as querelas que teve com contemporâneos, nomeadamente "práticos", em que são frequentes as suas defesas altivas da superioridade do saber científico.) O matemático português foi, neste século e no seguinte, um caso único, aliás não só

em Portugal como em toda a Península Ibérica. "Fuera de una y otra nación [Portugal e Espanha] vivió espiritualmente", diz J. Rey Pastor (*Los matemáticos españoles del siglo XVI*, Madrid, 1926).

A Academia das Ciências de Lisboa iniciou nos anos 40 um notável projecto de publicação das *Obras* de Pedro Nunes. Dos seis volumes previstos, foram publicados quatro, estando a série interrompida há quase 40 anos, praticamente desde a morte do seu grande impulsionador, o professor de Coimbra Joaquim de Carvalho. Seria uma pena que a publicação não fosse completada, por exemplo a tempo do 5º centenário do nascimento de Pedro Nunes, em 2002.

Deixamos a seguir um apontamento, muito resumido e incompleto, sobre outras actividades matemáticas em Portugal nos séculos XVI a XVIII.

Pedro Nunes foi cosmógrafo-mor do Reino a partir de 1547, um cargo criado nessa data. Uma das obrigações do cosmógrafo-mor era uma aula diária de Matemática (aplicada à náutica, já se vê). O cargo foi abolido em 1779 para dar lugar à Academia Real de Marinha.

No Colégio jesuíta de Santo Antão, em Lisboa, funcionou desde fins do século XVI até ao século XVIII uma *Aula de Esfera*, pública, que chegou a ter frequência apreciável. Para além da Matemática aplicada à navegação, aí se estudava Astronomia, Geometria, Aritmética, etc.

Além de Santo Antão e da Universidade de Évora, tiveram os jesuítas aulas de Matemática, por vezes públicas, em vários colégios, nomeadamente em Coimbra. Para ajudar a assegurar esse serviço, vieram muitos professores estrangeiros, em particular italianos e alemães. Dignos de registo, alguns com trabalhos de astronomia, náutica e cartografia, são os nomes de Grienberger (mais tarde sucessor de Clavius no Colégio Romano), Borri (que na primeira metade do século XVII divulgou entre nós as manchas solares e Galileu), Stafford, Estancel, Capassi e Carbone. Os dois últimos estão associados à criação do Observatório Astronómico do Colégio de Santo Antão.

Capassi partiu em 1729 para o Brasil com outro professor jesuíta, Diogo Soares, em cumprimento do encargo dado pelo Rei D. João V de elaborar o mapa do grande Estado transatlântico. A elaboração de mapas é aliás uma das vertentes principais da actividade matemática neste período. Já o jesuíta suíço João König, chamado em 1682 para ocupar a cadeira de Matemática da Universidade de Coimbra, vaga há muito tempo, abandonou o ensino quatro anos depois, por ordem do Governo, para elaborar um mapa de Portugal.

A partir de meados do século XVII, com a guerra da independência, recebem impulso os estudos de Matemática aplicada às actividades militares. Data desta altura a criação da Aula de Fortificação e Arquitectura Militar. Também em Santo Antão se deu atenção a estes tópicos. Muito mais tarde, no século XVIII, têm interesse os estudos de Matemática aplicada à artilharia em unidades e academias militares.

Desta breve resenha o que ressalta é a feição prática, ou aplicada, que ela sugere sobre o estudo da Matemática em Portugal neste período. Com o patrocínio do Estado ou nas escolas da Companhia de Jesus, estudam-se matérias vistas como correspondendo a necessidades concretas imediatas do País.

A consulta da lista dos trabalhos matemáticos redigidos em Portugal ou por portugueses neste período revela um panorama análogo. Nota-se uma clara predominância de obras dedicadas a temas dentro do que se poderá chamar Matemática Aplicada: náutica, efemérides astronómicas, atlas e cartas (incluindo plantas de fortalezas), geometria aplicada à fortificação, aritmética aplicada a actividades financeiras. Interessante é a frequência de registos de observações astronómicas (eclipses lunares, cometas). Pormenor a reter é o de que muitas destas obras existem apenas em manuscrito.

Parece inequívoco que, no período que nos vem interessando, a Matemática portuguesa não acompanhou nem tomou parte nos grandes avanços da época, e ao não cultivo da Matemática "Pura" poderá ser associada a necessidade frequente de recrutar professores estrangeiros para assegurar o ensino, mesmo da Matemática elementar, nas nossas escolas, por cá não haver quem o fizesse.

O quadro mental e cultural português no período em causa está suficientemente documentado e estudado e não é necessário recordá-lo aqui. Os seus reflexos na nossa vida matemática (ou falta dela) decorrem basicamente do facto de que os grandes progressos científicos da época estiveram em geral associados a propostas filosóficas contra as quais as autoridades políticas e religiosas nacionais estavam em prevenção constante, o que produzia uma explícita atitude de recusa genérica da novidade na instrução. Quanto à situação geral do País, menos ainda é preciso evocá-la como pano de fundo para tudo o resto.

Na primeira metade do século XVIII, entretanto, multiplicam-se os sinais de uma mudança de ambiente. Dentro e fora do país, surgem vários portugueses interessados nas modernas tendências científicas. Ocorrem, entre outros, os nomes de Jacob de Castro Sarmiento (com uma newtoniana *Theorica verdadeira das marés*, Londres, 1737), José Soares de Barros e Vasconcelos, astrónomo muitos anos em Paris, Manuel de Azevedo Fortes, engenheiro, autor de uma *Logica racional, geometrica e analytica* (Lisboa, 1744), Teodoro de Almeida, da Congregação do Oratório, com a sua *Recreação Philosophica*, e os jesuítas Eusébio da Veiga, astrónomo em Lisboa, Manuel de Campos e Inácio Monteiro. Todos estes autores merecem análises modernas (só o último deles foi estudado em trabalhos recentes, de Resina Rodrigues e Ana Isabel Rosendo).

2. A Matemática em Portugal de 1772 a 1910 (Jaime Carvalho e Silva)

A Reforma em 1772 da Universidade, desde 1537 definitivamente instalada na cidade de Coimbra, representa a maior alteração qualitativa e quantitativa do

panorama da matemática em tão curto espaço de tempo alguma vez empreendida em Portugal. Em Dezembro de 1770 é nomeada a Junta da Providência Literária, que apresenta o seu relatório em Agosto de 1771 no "Compêndio Histórico do Estado da Universidade". Aí se observa que as Ciências em geral e a Matemática em particular tinham atingido na Universidade um nível muito baixo, de tal modo que nos 60 anos anteriores à Reforma a única cadeira de Matemática de toda a Universidade não tinha tido titular. Nesse documento a Matemática era considerada "...sciência importante ao bem comum do Reino, e Navegação, e ornamento da Universidade." Não admira assim que, nos Estatutos da Universidade aprovados em Outubro de 1772 com grande pompa e solenidade e na presença do Ministro do Rei D. José I, o Marquês de Pombal, o grande motor de todas as transformações, sejam criadas duas novas Faculdades: a de Matemática e a de Filosofia (Natural). A Matemática é colocada numa posição muito elevada nesses Estatutos: "Têm as Mathematicas uma perfeição tão indisputável entre todos os conhecimentos naturais, assim na exactidão luminosa do seu Método, como na sublime e admirável especulação das suas doutrinas, que Ellas não somente e em rigor, ou com propriedade merecem o nome de Sciencias, mas também são as que tem acreditado singularmente a força, o engenho, e a sagacidade do Homem." E são mesmo indicadas penas para quem diminuir a importância dos estudos matemáticos: "Todos aquelles, que directa ou indirectamente apartarem ou dissuadirem a alguém dos estudos mathematicos; (..) não serão por mim attendidos em opposição alguma, que façam às cadeiras das suas respectivas Faculdades."

Para a nova Faculdade de Matemática são contratados dois professores italianos e dois portugueses: estes, de formação essencialmente autodidacta, merecem menção especial pelos trabalhos originais que produziram: José Monteiro da Rocha, que trabalhou em Métodos Numéricos e Astronomia, e José Anastácio da Cunha, que escreveu um tratado, "Principios Mathematicos", onde pretendia fornecer bases rigorosas a toda a Matemática da época; aí se encontra pela primeira vez, com um rigor notável, a definição de série convergente, a definição da função exponencial a partir da sua série de potências, e a de diferencial de uma função. Infelizmente o seu livro, apesar de ter tido duas edições em língua francesa, foi pouco lido e não parece ter influenciado grandemente o desenvolvimento da matemática.

Um dos principais impactos da criação da Faculdade de Matemática foi na formação de especialistas em Matemática. Uma das primeiras pessoas a doutorar-se depois da Reforma de 1772 foi Frei Alexandre de Gouveia, que viria a ser bispo de Pequim e aí membro do muito importante Tribunal da Matemática.

Para se ter uma ideia melhor da amplitude desta formação, eis o quadro dos doutoramentos em Matemática na Universidade de Coimbra até ao fim do século XIX:

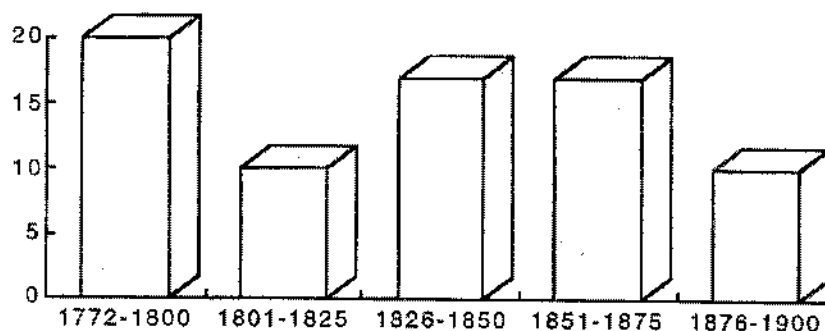

Muitos dos doutorados ficaram professores da Faculdade de Matemática, mas outros tornaram-se professores das diversas Academias Militares e das Academias Politécnicas de Lisboa e do Porto. Muitos dos bacharéis e licenciados chegaram também a professores dessas escolas, pelo que é de salientar o aspecto multiplicador que teve a criação da Faculdade de Matemática em Coimbra.

Infelizmente o impacto não foi tanto quanto o idealizou o Marquês de Pombal ou Monteiro da Rocha, redactor dos Estatutos e primeiro Director da Faculdade de Matemática. Os alunos acorreram em pouco número, a publicação de textos de matemática foi muito dificultada e a instabilidade política não foi propícia; desde 1807, data do início das Invasões Francesas, até 1834, data do fim da guerra civil, toda a actividade científica foi grandemente reduzida; muitos professores foram forçados a abandonar o seu lugar, exilados uns, mortos outros, chegando mesmo a Universidade a estar fechada nos anos lectivos de 1810-1811, 1828-1829, 1831-1832, 1832-1833 e 1833-1834 (outras instabilidades políticas posteriores também se reflectiram na funcionamento da Universidade, tendo estado ainda fechada em 1846-1847, assim como noutros períodos mais curtos).

A maioria dos trabalhos de Matemática publicados em Portugal nos fins do século XVIII e princípios do século XIX devem-se à Academia das Ciências, fundada em Lisboa em 1799 pelo Duque de Lafões, tio da Rainha D. Maria I. A Academia iniciou a publicação das suas Memórias em 1787, embora só a partir de 1797 começassem a aparecer os primeiros trabalhos de Matemática, sendo o primeiro justamente de José Monteiro da Rocha sobre o problema de Kepler da medição de pipas e tonéis. Esta Academia teve uma actividade considerável até sofrer também o impacto das Invasões Francesas e da Guerra civil.

Como afirma Luís Woodhouse na conferência de abertura da Secção de Ciências Matemáticas do Congresso conjunto das Associações Portuguesa e Espanhola para o Progresso das Ciências que se realizou em Coimbra em 1925, "esta quadra da história dos conhecimentos matemáticos em Portugal, desde o seu renascimento após a reforma da Universidade de Coimbra em 1772, até aos fins do século XVIII e depois nos primeiros anos do século XIX até que as perturbações políticas, profundas e constantes, acabaram por desagregar e dispersar os elementos vitais da

sciência matemática portuguesa, não é de todo falha de interesse, não é vã nem estéril, embora seja curta".

Só depois do fim da guerra civil foi possível avançar com novas Reformas ao nível educativo. A Universidade e a Academia das Ciências retomaram a sua actividade, não sem algumas dificuldades. Apesar da oposição da Universidade, em 1837 foram fundadas as Academias Politécnicas de Lisboa e do Porto que em 1911 dariam origem às Faculdades de Ciências das também então criadas Universidades de Lisboa e do Porto. A Faculdade de Matemática e a Faculdade de Filosofia da Reforma Pombalina dariam origem à Faculdade de Ciências da Universidade de Coimbra. Estavam assim criadas as condições para um salto qualitativo do desenvolvimento da matemática em Portugal, com três escolas portuguesas a formar matemáticos e de algum modo a competir em brio entre si.

Esboçemos ainda um breve panorama das publicações matemáticas em Portugal.

Até meados do século XIX, as principais publicações de matemática foram praticamente as das *Memórias da Academia das Ciências*. Só a partir de 1857 começaram a ser obrigatoriamente publicadas na Universidade as dissertações de doutoramento, onde se encontram muitos trabalhos de interesse, revelando que a matemática portuguesa estava a par da matemática produzida na época.

A investigação científica estava contemplada nos Estatutos de 1772, onde se preconizava a criação da "Congregação geral das sciências para o adiantamento, progresso e perfeição das sciências naturais". Contudo tal intenção nunca passou do papel e os contactos com matemáticos estrangeiros eram muito limitados. É verdade que em Portugal eram recebidas as melhores publicações da Europa culta, mas frequentes vezes matemáticos portugueses desenvolviam métodos que eram mais tarde redescobertos por outros, como aconteceu com Monteiro da Rocha, Anastácio da Cunha, Garção Stockler, Dantas Pereira ou Daniel da Silva. Só com o lançamento do *Jornal de Sciencias Matematicas e Astronomicas* em 1877, por iniciativa de Francisco Gomes Teixeira, é que se desenvolveram verdadeiramente as relações dos matemáticos portugueses com os seus colegas europeus, dando uma real divulgação aos trabalhos portugueses, tendo também muitos artigos de matemáticos estrangeiros sido por este meio publicados em Portugal.

Os Estatutos de 1772 determinavam que se editassem livros para cada uma das cadeiras. Foram feitas várias traduções, mas muito poucos originais foram produzidos. O professor Luis da Costa e Almeida propôs mesmo ao Conselho Superior de Instrução Pública, em 1886, que fosse atribuída uma "remuneração pecuniária" aos professores encarregados da composição dos compêndios, "equivalente ao serviço de regência da cadeira". Contudo, o primeiro livro de texto original português que teve real impacto internacional foi o "Curso de Analyse Infinitesimal" em três volumes (1887-1892) de Francisco Gomes Teixeira, que recolheu recensões extremamente favoráveis no *Bulletin des Sciences Mathématiques* e no *Bulletin of the American Mathematical Society*. Este livro, que

foi adoptado durante muitos anos na Universidade e na Academia Politécnica do Porto, introduziu em Portugal muitas noções de análise avançada, algumas das quais eram contribuições originais do próprio Gomes Teixeira.

3. A Matemática em Portugal desde 1910 (António Leal Duarte)

Ao examinarmos a actividade matemática em Portugal até aos finais do séc. XIX, a principal característica que se nos apresenta é a do isolamento em que a comunidade matemática portuguesa quase sempre viveu; de facto, com excepção de Pedro Nunes, essa comunidade e a sua actividade são praticamente desconhecidas no estrangeiro. Ao contrário, a primeira característica que a actividade matemática nos apresenta durante o séc. XX é a quebra deste isolamento. Essa quebra inicia-se nos finais do séc. XIX com Gomes Teixeira, mas será já no séc. XX que outros matemáticos portugueses começam a ser conhecidos no estrangeiro e a publicar os seus trabalhos nalgumas das melhores revistas estrangeiras da especialidade. Refira-se por exemplo A. Mira Fernandes (com vários trabalhos sobre Geometria Diferencial e Cálculo Tensorial publicados em revistas italianas) e J. Vicente Gonçalves (cujos trabalhos, apesar de publicados em revistas portuguesas e por vezes escritos em Português, se tornam conhecidos fora de Portugal).

Com as reformas educativas, levadas a cabo pelos governos republicanos, são criadas duas novas Universidades e são criados ou reformulados outros institutos superiores. Mas, talvez mais importante do que este aumento do número de Escolas seja a tentativa de criação, em 1923, pelo Ministro da Instrução Pública, António Sérgio, de um organismo especificamente encarregado da investigação científica. Este organismo, que só virá a ser criado em 1929 com o nome de Junta de Educação Nacional, terá, entre outras, a missão de enviar bolseiros para o estrangeiro.

Nos anos trinta deste século assiste-se a uma modernização do ensino com a publicação de novos compêndios, no caso da Análise, por Vicente Gonçalves e, no caso da Álgebra, por A. Almeida Costa, o qual pode ser considerado o introdutor da Álgebra Moderna em Portugal.

Os anos quarenta vão ser extremamente férteis no que diz respeito à actividade matemática graças a uma nova geração de matemáticos (entre os quais se contam Aniceto Monteiro, Ruy Luís Gomes e Hugo Ribeiro). É a esta geração que se deve a criação da Sociedade Portuguesa de Matemática e da conceituada revista de investigação *Portugaliae Mathematica*.

Infelizmente esta actividade foi em grande parte suspensa, pois muitos dos seus principais animadores foram, por motivos políticos, demitidos da Função Pública e obrigados a exilar-se fora do País.

Nos anos cinquenta e sessenta devemos referir a acção de J. Sebastião e Silva, quer como investigador e formador de uma nova geração de Matemáticos, quer também como pedagogo, nomeadamente na reformulação dos programas do ensino secundário.

Também na década de sessenta o ensino universitário passa por uma grande actualização de planos de estudo com a introdução de novas disciplinas (como a Topologia).

Actualmente existem em Portugal várias escolas de matemática de craveira internacional, de que se destacam as de Análise Funcional e Equações Diferenciais (iniciada por J. Sebastião e Silva), de Álgebra (uma iniciada por A. Almeida Costa e outra iniciada por Luís de Albuquerque) e de Estatística (fundada por J. Tiago de Oliveira).

4. A historiografia da Matemática em Portugal (João Filipe Queiró)

Justifica-se neste momento uma reflexão sobre os rumos que os estudos de História da Matemática poderiam ou deveriam tomar no nosso país.

Se se procurar, vê-se que há exactamente quatro obras de alguma dimensão que se podem considerar "Histórias da Matemática em Portugal":

Memórias históricas sobre alguns matemáticos portugueses, e estrangeiros domiciliados em Portugal, ou nas conquistas - António Ribeiro dos Santos, 1812

Ensaio histórico sobre a origem e progressos das Matemáticas em Portugal - Francisco de Borja Garção Stockler, 1819

Les Mathématiques en Portugal - Rodolfo Guimarães, 1900-1909

História das Matemáticas em Portugal - Francisco Gomes Teixeira, 1934

Atente-se nas datas. É significativo que nos últimos 60 anos não haja uma única tentativa de síntese neste terreno. E é significativo porque as "Histórias" existentes de alguma forma fixam um paradigma, uma maneira de ver as coisas, que influencia qualquer leitor que tente obter informação sobre o assunto.

Fique desde já claro que todos os quatro textos citados são de grande valor, e cada um a seu modo foi importante contribuição para os estudos de História da Matemática no nosso país. Rodolfo Guimarães, por exemplo, depois de uma nota histórica, tem como objectivo listar *todos* os textos matemáticos de autores portugueses, ou publicados em Portugal, até ao fim do século XIX. Gomes Teixeira, por seu lado, dedica grande parte da sua História à análise aprofundada de quatro grandes figuras, Pedro Nunes, Anastácio da Cunha, Monteiro da Rocha e Daniel da Silva. Quanto a Stockler, foi um pioneiro, e o seu *Ensaio* foi obra

marcante. O que se vai dizer a seguir não pretende minorizar estas personalidades e as suas obras.

A verdade é que os livros de Garção Stockler, Rodolfo Guimarães e Gomes Teixeira (o texto de Ribeiro dos Santos é um pouco marginal nesta questão) reflectem uma visão que se poderia chamar "antiquada" da História de Portugal, e essa visão tende a obscurecer certos períodos e a distorcer a abordagem ao nosso passado, no caso o nosso passado matemático.

A visão em causa é a visão, digamos assim, "dominante" da História geral de Portugal no século XIX. É a visão das Luzes, da influência da Revolução Francesa, do liberalismo. Muito natural e compreensivelmente, esta visão tem uma leitura quase "de combate" sobre o passado recente, e nessa leitura é praticamente um axioma que os dois séculos anteriores a Pombal foram uma época de trevas, de obscurantismo, de intolerância e de ignorância. O negrume é ainda maior quando se pensa no Humanismo de meados do século XVI, que em Portugal esteve ligado ao florescimento da arte, da cultura e da ciência que acompanhou a era dos Descobrimentos.

Esta visão é reflectida exactamente no *Ensaio* de Stockler, que, recorde-se, é de 1819. Portugal tem na Matemática um período de esplendor no século XVI, em que se destaca Pedro Nunes, depois um período de decadência que dura 200 anos, até à Reforma Pombalina da Universidade de Coimbra, em que aparecem figuras importantes como José Anastácio da Cunha.

Quase 100 anos depois da publicação do *Ensaio* de Stockler, Rodolfo Guimarães retoma ponto por ponto, na nota histórica com que se inicia a sua obra, a mesma visão, chegando quase a transcrever partes do livro anterior. Quanto a Gomes Teixeira, não imita nem transcreve, mas a visão geral é ainda a mesma.

Ora bem. O estudo da História Geral do nosso país evoluiu muito do século passado até hoje. Em particular, a distância aumentou em relação à época da Inquisição e da influência dos jesuítas na sociedade portuguesa, e esse período é hoje estudado e analisado como qualquer outro na História de Portugal.

Mas na História da Matemática não se saiu do sítio! A visão geral continua a mesma. Como os estudos sobre autores particulares e pontos de pormenor são raros (devem citar-se, entre os poucos nomes relevantes, além de Gomes Teixeira, os de Vicente Gonçalves e Luís de Albuquerque), temo-nos visto reduzidos à repetição sem fim dos mesmos pontos de vista, sem nova informação, e remetendo-nos permanentemente às mesmas fontes, que são basicamente as indicadas.

Neste momento é apropriado ter as ideias claras e propor o que pomposamente se poderia chamar uma "mudança de paradigma". A visão atrás descrita, sem prejuízo do grande valor e importância de autores como Stockler, Guimarães e Teixeira, parece hoje esgotada, redutora, irremediavelmente datada e, pior, anestésiante. A continuar assim, longos períodos e muitos autores permanecerão em obscuridade na História da Matemática em Portugal.

Para tal mudança adiantam-se como possíveis as seguintes linhas:

1) Prioridade ao estudo do período que medeia entre a morte de Pedro Nunes, em 1578, e a Reforma Pombalina, em 1772, e também do século XIX. Estes são os períodos que menos atenção têm recebido e surgem quase envolvidos numa aura de mistério.

2) Prioridade àquilo que se costuma chamar "História positiva": listagem de autores e obras (estendendo e completando o extraordinário trabalho de Rodolfo Guimarães), localização de obras — impressas e em manuscrito — e sua microfilmagem, programa de edição (ou reedição) das mais significativas. Estudo dessas obras. Estudo da recepção em Portugal dos grandes avanços matemáticos dos séculos XVII e XVIII. Quanto ao século XIX, estudo das teses de Coimbra e das comunicações e memórias da Academia das Ciências de Lisboa. Tudo isto dentro da consciência perfeita de que a História da Matemática em Portugal tem que ser uma *História de fontes primárias*, com total abandono da repetição acrítica de fontes secundárias.

3) Estudo, com base no material recolhido, de algumas *hipóteses*, que poderiam servir de baliza e orientação neste esforço. Exemplos (entre outras possíveis):

- Existiu ou não ênfase quase exclusiva na "Matemática Aplicada" em Portugal nos séculos XVI a XVIII?

- Se sim, teve isso ligação essencial com o esforço dos Descobrimentos, a rotina das grandes viagens oceânicas, as necessidades concretas resultantes do contacto com os territórios de destino e respectivas populações?

- A confirmar-se um panorama de grande pobreza na nossa Matemática no período 1578-1772, será adequado o uso da expressão "decadência", que sugere queda de alguma (ainda que pouca) altura? Por outras palavras, terá Pedro Nunes sido o expoente de uma plêiade, mais ou menos numerosa, de matemáticos quinhentistas, ou tratou-se de uma singularidade absoluta?

- Mantiveram-se os matemáticos portugueses no século XIX minimamente actualizados em relação à Matemática europeia?

Termine-se com o óbvio. Nada disto será feito se não houver ninguém que o faça. Temos de acreditar que esta é uma tarefa que vale a pena, e que ela cabe a matemáticos, em particular a matemáticos portugueses. Quem sabe se dentro de alguns anos — que nunca poderão ser poucos — não se estará em condições de escrever uma nova História da Matemática em Portugal?

(1). Há um estudo muito recente de Carlos Vilar.

MATHEMATICS IN SOUTH AND CENTRAL AMERICA

by Ubiratan D'Ambrosio*

1. Historiographical remarks.

We adopt a chronology based on five major divisions: pre-columbian; conquest and early colonial times; the established colonies; independent countries; the XX century.

Geographic divisions are very important. For the pre-columbian period we adopt the usual focus on the Aztec, Maya and Inca civilizations, although there are much finer divisions, both based on political and cultural specificities. A special study of pre-columbian mathematics would need this refinement. After the conquest, we follow the administrative organization in Viceroyalties: New Spain (roughly what is today Mexico and upper Central America), New Granada (southern Central America, approximately Costa Rica, Colombia, Venezuela, Ecuador), Peru (roughly Peru and Bolivia), La Plata (roughly what is now Chile, Paraguay, Argentina and Uruguay) and, under Portugal, the Viceroyalty of Brazil. From the independence on, with a few exceptions, the current political division is appropriate.

In what follows, historical periods are defined according to the general chronology associated with the conquest and colonization of the Americas. Beginning with the independence movements at the beginning of the 19th century until the present, the cultural map is roughly the same.

2. Pre-columbian History of Mathematics.

Our knowledge of the pre-columbian period is still very incomplete. There was a clear effort made by the colonial regimes to ignore or obliterate any sense of the history or historic achievement of the native cultures. Today we are faced with the difficult task of reconstructing the histories of these cultures in space and time. Of course, this affects the History of Mathematics in Pre-columbian times, a very new field.

Above all there was modest interest in describing pre-columbian mathematical knowledge among the chroniclers, mainly those who reported

* Rua Peixoto Gomide 1772, ap. 83 ; 01409-002 São Paulo, SP; Brazil; tel: 55-11-280.0266; fax: 55-11-282.5437; e-mail: ubi@usp.br.

on the Peruvian quipus, although these were hardly identified and barely recognized as a form of mathematical knowledge. A basic reference, however, is the **Bernabé Cobo**: *Historia del Nuevo Mundo* [1653], Atlas, Madrid, 1964. Yet to be explored but doubtless rich in historic material are the archives of the Jesuit missionaries, as well as other religious orders.

A good survey of pre-columbian Mathematics is in the book *Native American Mathematics* ed. Michael Closs, University of Texas Press, Austin, 1986.

3. Conquest and early colonial times.

Although to be covered in another paper, it is imperative to mention the developments in the Nueva España. Most of the developments in Central and South America are dependent on the important and strategic position of Mexico in the New World.

In the early colonial times, the Spanish and the Portuguese tried to establish schools, mostly run by Catholic religious orders. The demand for mathematics in these schools were essentially for economic purposes related to trade, but there was also an interest on mathematics related to astronomical observations. Reliance on indigineous knowledge was limited, but there was some interest in the nature of native knowledge.

The first non-religious book published in the Americas is an arithmetics book related to mining, the *Sumario compendioso de las quantas de plata y oro que en los reinos del Pirú son necessarias a los mercaderes y todo genero de tratantes. Con algunas reglas tocantes al arithmética*, by **Juan Diez freyle**, printed in New Spain in 1556. It is a book on arithmetics as practiced by the natives, to which the author adds some questions on the resolution of quadratics. In the following century we have practical books published in Mexico, such as the *Arte menor de arithmetica*, by **Pedro de Paz**, in 1623, and *Arte menor de arithmética y modo de formar campos*, de **Atanasio Reaton**, in 1649. It is also to be noticed the book *Nuevas proposiciones geométricas*, written by **Juan de Porres Osorio**, in Mexico.

Astronomy is a major area of interest in Latin America in the XVII century. There are important discussions on the meaning of comets. They were related to divine messages and warnings. In another view, there is a search for scientific explanations. Several polemical exchanges of letters and papers are known from these times, with important epistemological arguments. The figure of Don **Carlos de Sigüenza y Góngora**, of Mexico, towers. His works focus on astronomical observations and calculations. His most

important book, considered one of the most important works of Latin American Science, is *Libra astronómica y filosófica*, written in 1690. In it Sigüenza y Góngora refutes prevailing astrological arguments about comets.

The same tone and of much importance is the work of **Valentin Stancel**, a Jesuit mathematician from Prague who lived in Brazil from . His astronomical measurements are mentioned in Newton's *Principia*. A polemic, which includes another jesuit, **Antonio Vieira**, reveals how important was the discussion on the nature of comets in building up modern scientific ideas.

Also in the Viceroyalty of Peru we have the same concerns. The first to be recognized as a mathematician is **Francisco Ruiz Lozano** (1607-1677), who wrote *Tratado de los Cometas*, essentially medieval mathematics explaining the phenomenon.

4. The established colonies.

In late colonial times from the middle of the 18th century, a good number of expatriates and *criollos* played an important role in creating a scientific atmosphere in the colonies. This happened under the influence of the *Ilustración* [Enlightenment], the important intellectual revival that began in Spain under Charles III and in Portugal under José I and his strong minister, the Marquis of Pombal. A number of intellectuals well versed in a variety of areas of knowledge were responsible for introducing Mathematics to the colonies. These include **Juan Alsina** and **Pedro Cerviño** in Buenos Aires, who lectured on Infinitesimal Calculus, Mechanics and Trigonometry. In Peru, **Cosme Bueno** (1711-1798), **Gabriel Moreno** (1735-1809) and **Joaquín Gregorio Paredes** (1778-1839) are best known. In Brazil, **José Fernandes Pinto Alpoim** wrote two books, *Exame de Artilheiros* (1744) and *Exame de Bombeiros* (1748), both focused on what we might call Military Mathematics, and using the form of questions and answers.

Among the South Americans of the pre-independence days, a rather distinguished figure is **José Celestino Mutis** (1732-1808), who not only is responsible for an unpublished translation of Newton, but was also responsible for introducing modern mathematics in Colombia, mainly relying on Christian Wolff. He was the founder of the Observatorio de Bogotá, in 1803. His most distinguished disciples is **Francisco José Caldas** (1771-1816), who became the director of the Observatory. Caldas was deeply involved in the Independence War and was shot by the Spaniards.

In Chile, the Universidad Real de San Felipe, which was inaugurated in 1747 in Santiago, was provided with a "catedra" of Mathematics. It was the *criollo* fray **Ignacio León de Garavito**, a self-instructed mathematician, who was responsible for this chair.

Again we have to mention Mexico, where we have the most important developments of mathematics in Latin America in these days. In the first half of the XVIII century there were a number of textbooks on Geometry, Arithmetics and Astronomy. These were not important, in the sense that were classical treatments, but in the second part of the century, there are some important contributions by mexicans. Particularly noticeable is the *Lecciones matemáticas*, of **José Ignacio Bartolache**, published in 1769. In 1772, an anonymous built a "calculating wheel", capable of performing the four basic operations for numbers up to 10^8 digits. In 1772 **Benito Bails** publishes *Elementos de matemáticas*, which treated infinitesimal calculus and analytic geometry. It is remarkable the development of a special kind of applied mathematics, stimulated by the complexity of problems related to water and to mining. These two constitute the most important problems in the technological development of the country. A "subterranean geometry" became a major theme in Mexican Science. The book *Comentarios a las Ordenanzas de Minas*, by **Francisco Javier Gamboa**, published in 1761, is most representative of these developments.

More to the South, in Guatemala, which included Costa Rica, the most renowned scholar is **José Antonio Liendo y Goicoechea** (1735-1814). He taught at the Universidad de San Carlos de Guatemala, which had already become a very important academic center after a plan of studies was published in 1785 in Latin as 25 theses, under the title *Temas de Filosofía Racional y de Filosofía Mecánica de los sentidos, de acuerdo con los usos de la Física; y de otros tópicos físico-teológicos según el pensamiento de los modernos para ser defendidos en esta Real y Pontificia Academia Guatemalteca de San Carlos ...*. This was essentially a medieval proposition. Goicoechea was responsible for modernizing this plan of studies, incorporating experimental physics to the project. He introduced modern mathematics through the texts of Wolff.

5. Independent countries.

The independence of the Viceroyalties of Nueva España, Nueva Granada, Peru, La Plata and Brazil was achieved in the first quarter of the 19th century. The process of modernization in the newly independent countries did not change the prevailing attitude towards Mathematics.

The political division in countries following the independence is practically the same as today. The independence of Guatemala as an independent country in 1821 lessened the influence of Mexico in Central and South America. The establishment of new university centers immediately preceding and following independence generated open attitudes with respect to sources of knowledge on which to build up the newly-established countries of Latin America. Formerly restricted to influences coming from Spain and Portugal, the new countries attracted considerable attention from the rest of Europe, and a number of scientific expeditions were sent to South America. They had a great influence in creating new intellectual climates throughout the region. This also created strong interest in building up large and diversified libraries. The influence of Auguste Comte towards the end of the century was very important and influenced a slow development of Mathematics and the Sciences in general.

In Costa Rica the colonial authorities established the Casa de Enseñanza de Santo Tomas in 1814, in which the most influential teacher was **Rafael Francisco Osejo**, born in 1780. He wrote in 1830 *Lecciones de aritmética*, written in the form of questions and answers, a common feature in that period, as noticed above in the case of Alpoim in Brazil. In 1843 the Casa de Enseñanza is transformed in the Universidad de Santo Tomas. There were established careers in Engineering but no career in Mathematics.

Colombia soon attracted foreign mathematicians. The Frenchman **Bergeron** initiated Descriptive Geometry. The Italian **Agustín Codazzi** (1793-1859) was influential in creating the Colegio Militar. **Lino Pombo** (1797-1862) was particularly influential in founding the Academia de Matematicas de Venezuela. He wrote a complete course of Mathematics.

In Brazil, a good development was the result of the transfer of the royal family of Portugal escaping from Napoleon invasion. They created in Rio de Janeiro a major Library and the Escola Militar, the first institution of higher learning in the colony, which had been raised to the status of metropolis. There a doctorate in Mathematics was established.

Particularly interesting is the case of **Joaquim Gomes de Souza** (1829-1863), known as "Souzinha", the first Brazilian mathematician with an European reputation. He published in the *Comptes Rendus de l'Académie des Sciences de Paris* and in the *Proceedings of the Royal Society* and his collected works were published posthumously as *Mélanges du Calcul Intégral* in Leipzig in 1889. His works in partial differential equations were permeated by very interesting historical and philosophical remarks, revealing access to the most important literature then available. This was possible to

the existence of important private collections in Maranhão, his home state in the Northeast. The knowledge of these libraries is as yet an open field of research.

In Buenos Aires, the private library of **Bernardino Speluzzi** (1835-1898) included the main works of Newton, D'Alembert, Euler, Laplace, Carnot and several other modern classics. **Valentin Balbin** (1851-1901), while Rector of the National College of Buenos Aires proposed in 1896 a new study plan which included history of mathematics as a distinct discipline.

In Peru, it is to be mentioned a development in Statistics, beginning with the book *Ensayo de estadística completa de los ramos económico-políticos de la provincia de Azángaro...* by **José Domingos Choquechuanca** (1789-1858), published in 1833.

In Chile, in 1842 is created the Universidad de Chile, with a Faculty of Physical and Mathematical Sciences. A most distinguished member of the Faculty is **Ramón Picarte**, a lawyer, who publishes in Paris *La división reducida a una adición*, accepted by the Academy of Sciences in 1859. Much emphasis is given to teacher training, with the support of German pedagogues. Fifteen German mathematicians, most with a doctorate, emigrated to Chile in 1889.

6. The XX century.

The developments of early XX century are as yet depending on research focused in countries and even states and provinces, an almost open field.

When we look into the scenario in the turn of the century, we see the Exact Sciences in Argentina, the same as in Chile, under a strong influence of Germany, mainly through the efforts for the development of the Astronomical Observatory of La Plata. **Richard Gans** (1898-), a physicist who emigrated to Argentina in 1912, was very influential in the development of Argentinian Science.

In 1917 the Spanish mathematician **Julio Rey Pastor** (1888-1962) visited Argentina where there he decided to remain for the rest of his life, but with frequent returns to Spain. In addition to making important contributions to mathematics, mainly to projective geometry, Rey Pastor is essentially noteworthy for his contributions to the history of mathematics, specially of Iberian mathematics and of the 16th century. Rey Pastor also marked new directions in historiography by drawing attention to the mathematical achievements that made possible the great age of navigation. A

representative of his contribution is *La Ciencia y la Técnica en el Descubrimiento de América*, Espasa-Calpe Argentina S.A., Buenos Aires, 1942.

A disciple of Rey Pastor in Argentina, **José Babini** (1897-1983), became one of the most distinguished historians of science and mathematics in Latin America. His career as a driving force of Mathematics in Argentina is significant. He was a founder of the *Unión Matemática Argentina*, and in 1920 he became Professor at the Universidad Nacional del Litoral. Besides having written many books and articles in non specialized periodicals, Babini contributed considerably to scholarship on the Jewish medieval contributions to Mathematics. His major work was doubtless the book he wrote with Julio Rey Pastor: *Historia de la Matemática*, Espasa-Calpe Argentina S.A., Buenos Aires, 1951. This is indeed among the important books in the history of mathematics. Unfortunately it has not as yet been translated into other languages.

In the 1930s, some European mathematicians emigrated to Argentina. Among them the distinguished Italian mathematician **Beppo Levi** (1875-1961), who established an important research center in Rosario, as well as the influential journal, *Mathematica Notae*. Well known for his seminal Theorem on Mathematical Analysis, Beppo Levi devoted much of his research to the history of mathematics. Particularly to be noticed is his book *Leyendo a Euclides*, Editorial Rosario S.A., Rosario, 1947, a critical analysis of the general organization of the *Elements*.

One of the important influences associated with Rey Pastor was **Luis Santaló**. Born in 1911, this Spanish mathematician, distinguished by his works on Integral Geometry, emigrated to Argentina during the Spanish Civil war. Santaló later became a most influential scholars in Mathematics, Mathematics Education and the History of Mathematics in all of Latin America. Santaló is a major researcher in Integral Geometry and has important contributions to the History of Geometric Probabilities and has published relevant studies on Buffon.

In neighbouring Uruguay, an important tradition of mathematical research was established early in the 20th century. An important representative of this movement, who was particularly devoted to the history of mathematics, was **Eduardo García de Zuñiga** (1867-1951). García de Zuñiga succeeded in creating a most important library in the history of mathematics at the Facultad de Ingeniería de la Universidad de la República, in Montevideo. His research was mainly in Greek Mathematics and his collected works have been published as García de Zuñiga, E. *Lecciones de Historia de las*

Matemáticas (ed. Mario H. Otero), Facultad de Humanidades y Ciencias de la Educación, Montevideo, 1992. In mid-century, **Rafael Laguardia** and **José Luiz Massera** were responsible for the creation of a most distinguished research group in the stability theory of differential equation in the Instituto de Matemática y Estadística de la Facultad de Ingeniería de la Universidad de la República, en Montevideo. In Brazil, the proclamation of the Republic in 1889 reenforced the influence of positivism. The Escola Militar, transformed in the Polytechnic School, granted 25 doctorates in Mathematics, most under comtian influence. In the beginning of the century, a number of young mathematicians were absorbing the most recent progresses of Europe. Among them **Otto de Alencar**, **Manuel Amoroso Costa**, **Teodoro Augusto Ramos** and **Lelio I. Gama**. In 1916 is founded the Academia Brasileira de Ciências. With the inauguration of the Universidade de São Paulo, the first university in full operation in Brazil, we see a new direction in Mathematics. We might say this is the beginning of systematic research in Mathematics in Brazil. **Luigi Fantapiè** and **Giàcomo Albanese**, distinguished Italian mathematicians, respectively in Functional Analysis and Algebraic Geometry, were responsible for initiating an important research school in São Paulo.

7. Contemporary developments: after the end of the Second World War.

After the Second World War, a number of European arrived in Latin America. Particularly important is the presence of **Antonio Aniceto Monteiro**, from Portugal, in Rio de Janeiro and in Bahia Blanca, Argentina. A symposium which will discuss the influence of Monteiro in these two centers will take place during the Segundo Seminário Luso-Brasileiro de História da Matemática, to take place in Brazil in April 1997.

It is much more difficult to write about the period beginning with the Second World War in a conference text. It is noticeable that this marks an increasing, now dominating, influence of the United States in the development of Mathematics in Latin America. Before Europe was the source of visitors and the place for Latin Americans to go abroad for studies. Although a large number of European mathematicians went to Latin America after Second World War, American influence, not only in Mathematics, became very strong. Among the Europeans,

Contemporary History is a more difficult task, since we have to refer to processes still going on and we risk stumbling into personal and political issues. This would be more in the line of a Sociology of Contemporary Mathematics and will not be contemplated in this paper. An important

meeting invited by the Centro de Cooperación Científica de la UNESCO para América Latina, in Montevideo, Uruguay, in 1951, the *Symposium sobre Algunos problemas matemáticos que se están estudiando en Latino America*.

There we learn of the work of **Wilhelm Damköhler**, a German specialist in the Calculus of Variations who was teaching at the Universidad Nacional de Tucuman, Argentina, and later went to the Universidad de Potosí, Bolivia; of **Leopoldo Nachbin**, of the Universidade do Brasil, who was then doing very advanced research on the Theorem of Stone-Weierstrass and launching a major school on Holomorphy and Approximation theory in Brasil; of the advances on Integral Geometry by **Luis Santaló**, one the most distinguished researchers in this area, in Facultad de Ciencias de la Plata, Argentina; of **Francis D. Murnanham**, who was building up an important research group on modern applied mathematics and matrix theory in the Instituto Tecnológico de Aeronáutica, in São José dos Campos, Brasil; of **Mischa Cotlar**, who in Facultad de Ciencias de Buenos Aires reported on his important works on Ergodic Theory in cooperation with **R. Ricabarra**; of **Mario O. González**, of the Universidad de la Habana, working on Differential Equations; of **Alberto González Domínguez**, of the Facultad de Ciencias de Buenos Aires, working on distributions and analytic functions; of **Peter Thullen**, of the O.I.T. office in Paraguay, on Several Complex Variables; of **Carlos Graeff Fernández**, of the Universidad de México, working on Birkhoff's gravitational theory; of **Godofredo Garcia**, of the Facultad de Matemáticas de Lima, on General Relativity; of **Kurt Fraenz**, of the Facultad de Ciencias de Buenos Aires, on the mathematical theory of electric circuits; of **Rafael Laguardia**, of the Instituto de Matematica y Estadística de la Facultad de Ingeniería de Montevideo, on Laplace transforms. Invited foreign mathematicians who had been lecturing in South America were **Paul Halmos** and **Gustav Doetsch**. Invited discussants were **Augustin Durañona y Vedia**, of the Facultad de Ciencias de La Plata; **Roberto Frucht**, of the Facultad de Matemáticas y Física de Santa María, Chile; **Pedro Pi Calleja**, of the Facultad de Ciencias de La Plata; **Cesario Villegas Mañe**, of the Facultad de Ingeniería de Montevideo.

This was the first attempt to have a picture of what was going on in mathematical research in Latin America. A number of mathematicians quite active in several countries were not invited to the meeting. Looking into the Mathematical Reviews we might be able to find how representative was this group on invitees.

This "name dropping" can not be thought as an account of what was going on in South America in 1950. It would be extremely useful to have a

repertory of everything that was published in Mathematics by Latin Americans. Several names not listed above will appear. It would also be an interesting question to ask why the names above were the invitees and not other mathematicians active and of a comparable qualification in Latin America. In other terms, how political were the invitations? These and other questions are enough to feed a considerable research in the History of Contemporary Mathematics in Latin America.

An important, although very incomplete, account of research in Mathematics going on in Latin America was given by Julio Rey Pastor in "La matemática moderna en Latino América", *Segundo Symposium sobre Algunos problemas matemáticos que se están estudiando en Latino América*, Villavicencio-Mendoza, 21-25 Julio 1954, UNESCO, Montevideo; p. 9-20.

A good perception of the developments of mathematics in Latin America can be obtained by the study of the Colóquios Brasileiros de Matemática, held every two years beginning in 1957 in Brasil, of the ELAM: Escuela Latinoamericana de Matemáticas, held in different countries, and the strong Latin American presence in the International Congress of Mathematicians and other international meetings.

8. Increasing interest in the History of Mathematics.

In the last several decades the interest in the history of mathematics has grown considerably throughout South America. The founding of the *Sociedad Latinoamericana de Historia de las Ciencias y la Tecnología* in 1983 stimulated the organization of national societies devoted to History of Science, including sections of History of Mathematics. Young mathematicians from Central and South America have recently obtained doctorates in history of mathematics in both Europe and in North America, a hopeful sign of the maturity and continuing professionalization of the subject throughout Latin America.

9. Additional References.

This is a very incomplete account of a vast subject. Current results are very partial and disperse. The project of the *Enciclopedia de las Ciencias y las Técnicas Iberoamericanas* proposed by Mariano Hormigón will put together more information for this important theme.

Some available references are given below.

Arboleda, Luis Carlos: Dificultades estructurales de la profesionalización de las matemáticas en Colombia, in Peset, José Luiz (ed.) *La Ciencia Moderna y el Nuevo Mundo*, CSIC/SLAHCT, Madrid, 1985; pp. 27-38.

Azevedo, Fernando de (org.): *As Ciências no Brasil*, Editora UFRJ, Rio de Janeiro, 1994 (ed. original 1955).

Babini, José: *Páginas para una Autobiografía*, Prólogo y notas de Nicolás Babini, Asociación Biblioteca José Babini/Ediciones Letra Buena, Buenos Aires, 1992.

D'Ambrosio, Ubiratan: O Seminário Matemático e Físico da Universidade de São Paulo. Uma Tentativa de Institucionalização na Década de Trinta in *Temas e Debates*, ano VII, nº4, 1994; pp.20-27.

González Orellana, Carlos: *Historia de la Educación en Guatemala* Editorial Universitaria, Guatemala, 1985.

Orellana C., Maurício: *Resumen de las Clases del Curso de Historia de la Matemática en América Latina y Venezuela*, Universidad Pedagógica Experimental Libertador, Caracas, 1991 (mimeographed).

Ramos, Gerardo: El desarrollo de la Matemática en el Perú in Yepes, Ernesto (editor) *Algunos aportes para el estudio de la historia de la ciencia en el Peru*, CONCYTEC, Lima, s/d; pp.15-19.

Santaló, Luis A.: La Matemática en la Facultad de Ciencias Exactas y Naturales de la Universidad de Buenos Aires en el período 1865-1930, *Bol. de la Acad. Nacional de Ciencias, Cordoba*, Tomo 48, 1970; pp.255-273.

Santaló, Luis A.: *Evolución de las Ciencias en la Republica Argentina 1923-1972, Tomo I: Matemática*, Sociedad Científica Argentina, Buenos Aires, 1972.

Silva, Clóvis Pereira da: *A Matemática no Brasil. Uma História do seu Desenvolvimento* Editora da Universidade do Paraná, Curitiba, 1992.

Trabulsee, Elías: *Ciencia y Tecnología en el Nuevo Mundo*, El Colegio de México/Fondo de Cultura Económica, Mexico, 1994.

Zuñiga, Angel Ruiz (ed.): *Historia de las Matemáticas en Costa Rica* Editorial de la Universidad de Costa Rica, San José, 1995.

HISTORICITE DE LA NOTION D'EVIDENCE EN GEOMETRIE ENTRE EVIDENCE VISUELLE ET EVIDENCE MANIPULATOIRE

Evelyne BARBIN, IREM Université Paris 7

L'évidence est "un caractère qui s'impose à l'esprit", elle ne peut être qu'un sentiment intime. Un raisonnement ou une assertion mathématique ne peuvent être évidents indépendamment de celui qui en juge, de celui qui dit ou qui écrit la phrase "cela est évident". La tâche de l'historien n'est donc pas de décréter l'évidence, mais de rechercher les caractères du raisonnement qui ont été déclarés comme évidents dans l'histoire. De ce point de vue, nous nous attacherons, non à examiner des raisonnements mathématiques avec nos propres familiarités mathématiques, mais à lire les déclarations d'évidence et à examiner les pratiques qui reposent sur des évidences. Nous analyserons les lectures de la géométrie grecque faites par Proclus et par Descartes, celles de la géométrie analytique par Lamy et par Poncelet, ou celles de la géométrie descriptive par Gergonne et par Chasles. Les confrontations entre lectures de disciples et de détracteurs ont également un caractère historique. Elles correspondent à des polémiques, qui ont pu être féroces, tant il est vrai que le caractère d'évidence concerne le travail du mathématicien dans ce qu'il a de plus profond et de plus vital.

Un discours raisonné sur des images

Dans la première proposition du Livre I des *Eléments*, Euclide résout le problème suivant : sur une droite limitée donnée AB , construire un triangle équilatéral. La construction est donnée sous une forme impersonnelle, le géomètre s'effaçant devant ce qu'il contemple¹ : *Que du centre A et au moyen de l'intervalle AB soit décrit un cercle BCD , et qu'ensuite du centre B , et au moyen de l'intervalle BA , soit décrit le cercle ACE , et que du point C auxquels les cercles s'entrecoupent soient jointes les droites CA , CB jusqu'aux points A , B (fig.1).*

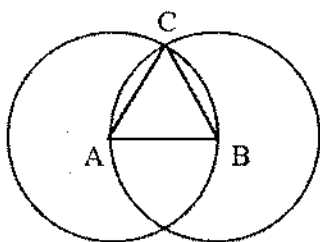

fig.1

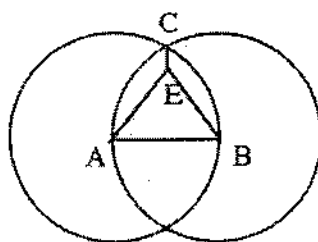

fig.2

Cette construction s'appuie sur deux demandes énoncées au début du Livre I : pouvoir décrire un cercle de centre et de rayon donnés, pouvoir mener une droite allant d'un point donné à un autre. Le raisonnement qui permet d'affirmer que le triangle ABC est équilatéral est un discours raisonné, constitué d'un ensemble de déductions, qui s'appuie sur une notion commune énoncée au début du livre I, à savoir que deux grandeurs égales à une même grandeur sont égales entre elles. Dans les *Commentaires sur le premier livre des Eléments d'Euclide*, écrits au 5ème

¹ Platon écrit que *la géométrie oblige à contempler l'essence*, *Les lois*, 521-527.

siècle, Proclus distingue les demandes, ou postulats, des notions communes, ou axiomes : les premières sont des choses faciles à admettre et les secondes sont des choses évidentes d'elles-mêmes. Mais, Proclus parle de *l'évidence des postulats et des axiomes* : ils doivent posséder tous deux *ce qui est simple et aisé à comprendre*².

Dans ses commentaires sur la proposition 1, Proclus rapporte l'objection de Zénon à cette construction : les deux droites CA et CB pourraient avoir une partie commune CE, et alors le triangle AEB ne serait pas équilatéral (fig.2). Cette objection est d'ordre logique, elle est là pour exhiber une défaillance des principes de la géométrie, car Euclide s'appuie sur une assertion qui n'est pas rendue manifeste par l'énoncé d'une demande ou d'un axiome. Mais Proclus ne rapporte aucune objection concernant l'existence du point C, c'est-à-dire la nécessité de démontrer que les deux cercles s'intersectent. L'évidence visuelle de l'intersection des deux cercles s'impose. Pour Proclus, cette proposition a la vertu de *nous remettre la nature des choses en mémoire comme par images*³, car il est manifeste pour tout le monde que le triangle équilatéral est le plus beau des triangles et qu'il est très apparenté au cercle. L'image permet de comprendre les alliances intimes entre deux figures parfaites.

Mais cela ne signifie pas que le géomètre doive s'en remettre à la seule vue. Ainsi, Proclus légitime le théorème de la proposition 20 du même Livre d'Euclide, qui énonce que dans tout triangle, deux côtés, pris ensemble de quelque façon que ce soit, sont plus grands que le côté restant. Il rétorque aux Epicuriens, qui le décriaient en disant *qu'il est évident même pour un âne, que ce théorème est évident pour les sens, mais ne l'est pas encore par le raisonnement scientifique [...] il appartient à la science de nous dire la manière dont cela se produit*⁴. Tout énoncé évident par les sens qui n'a pas le statut d'axiome doit être démontré. L'évidence doit être travaillée par le raisonnement logique.

La proposition 20 est un diorisme⁵ qui permet de résoudre le problème 22, à savoir de construire un triangle avec trois droites égales à trois droites données. Euclide ajoute à l'énoncé du problème une condition : il faut que deux quelconques de ces droites soient plus grandes que la troisième. Comme pour la proposition 1, la construction repose sur celle de deux cercles dont Euclide admet qu'ils s'intersectent. Dans son commentaire, Proclus demande : mais comment l'admet-il ? Il fait remarquer que deux cercles peuvent être disjoints, se toucher ou se couper, et il démontre que les deux premières possibilités conduisent à des contradictions. Lorsque les deux cercles se touchent, il n'examine que le cas où les cercles sont extérieurs l'un à l'autre. Puis il conclut qu'Euclide *a admis, comme il fallait, que les cercles se coupent mutuellement ; car il a supposé que parmi les trois droites il y en a deux qui, prises ensemble, sont plus grandes que la troisième*. De la sorte, son commentaire semble là, plus pour justifier l'énoncé de la condition, que pour démontrer l'existence du point d'intersection. Il explique comment Euclide a été conduit à énoncer sa condition. La question du comment est posée par Descartes, dans un contexte très large, au 17^{ème} siècle.

² PROCLUS, *Commentaires sur le premier livre des Eléments d'Euclide*, trad. Ver Eecke, Desclée de Brouwer, p.159. Aristote écrit dans les *Seconds analytiques* qu'il est nécessaire que la science démonstrative parte de prémisses qui soient vraies, premières et immédiates, plus connues que la conclusion, antérieures à elles, et dont elles sont les causes.

³ PROCLUS, op.cit., p.183.

⁴ PROCLUS, op.cit., pp.275-276.

⁵ c'est-à-dire une condition nécessaire à l'énoncé d'un problème.

L'évidence cartésienne

Dans la Règle IV des *Règles pour la direction de l'esprit*, Descartes exprime ainsi son insatisfaction à la lecture des démonstrations des ouvrages d'arithmétique et de géométrie : *Certes, j'y lisais sur les nombres une foule de développements dont le calcul me faisait constater la vérité ; quant aux figures, il y avait beaucoup de choses qu'ils me mettaient en quelque sorte sous les yeux mêmes et qui étaient la suite de conséquences rigoureuses. Mais pourquoi il en était ainsi et comment on parvenait à le trouver, ils ne me paraissaient pas suffisamment le montrer à l'intelligence elle-même*⁶. Les ouvrages n'indiquent pas pourquoi le mathématicien se propose de démontrer tel résultat, ni comment il parvient à le démontrer. La vision et la forme logique permettent de constater la vérité des résultats, d'en être convaincu, mais elle ne permet pas de résoudre de nouveaux problèmes.

Pour comprendre l'insatisfaction cartésienne, lisons de son point de vue la proposition 11 du livre II des *Eléments* d'Euclide. Il s'agit de couper en un point H une droite donnée AB de telle sorte que le rectangle de côtés HB et BD, égal à AB, soit égal au carré de côté AH. Euclide met sous les yeux la construction. Que le carré de côté AB soit décrit, que soit pris E le milieu de AC, que EB soit jointe, que soit placée EF égale à EB, que le carré de FH soit décrit sur AF, alors écrit Euclide : *je dis que AB a été coupée en H [...]* de façon voulue (fig.3). Ensuite, il démontre que le rectangle est bien égal au carré par une suite de déductions rigoureuses s'appuyant sur les notions communes ou sur les propositions démontrées précédemment. Descartes est obligé de constater que le résultat mis sous ses yeux est vrai, mais il ne sait pas comment Euclide a découvert la construction du point H. Il veut connaître le processus qui a permis d'inventer le point H, il questionne l'évidence de la démarche : *le je dis que*.

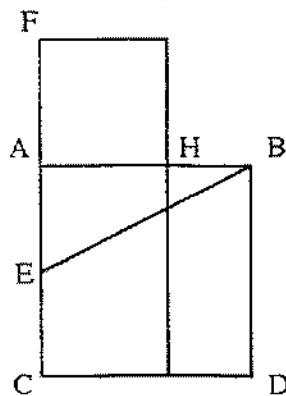

fig.3

L'évidence qui intéresse Descartes n'est pas celle de l'image, elle n'est pas celle du discours logique, c'est celle du géomètre travaillant sur des objets évidents, c'est-à-dire simples. Pour cela, il ramène tous les objets de la géométrie à des lignes simples, à des droites, qui seront unifiées à l'aide d'une droite unité. Ainsi, résoudre un problème c'est établir des relations entre des droites (finies). Il énonce ainsi la méthode pour résoudre n'importe quel problème de géométrie dans *La géométrie* de 1637 : *Ainsi voulant résoudre quelque problème, on doit d'abord le considérer comme déjà fait, et donner des noms à toutes les lignes, qui semblent nécessaires pour le construire, aussi bien à celles qui sont inconnues qu'aux autres. Puis sans*

⁶ DESCARTES, *Règles pour la direction de l'esprit*, trad. Sirven, Vrin, p.23.

considérer aucune différence entre ces lignes connues et inconnues, on doit parcourir la difficulté, selon l'ordre qui montre le plus naturellement de tous en quelle sorte elles dépendent mutuellement les unes des autres, jusqu'à ce qu'on ait trouvé un moyen d'exprimer une même quantité en deux façons ce qui se nomme une équation⁷. Les segments connus et inconnus seront désignés par des lettres, et la résolution passe par une mise en équation du problème. C'est une analyse dans le sens qu'elle va de l'inconnu au connu, mais ici le connu n'est pas la ou les propositions considérées comme évidentes, le connu désigne des segments donnés ou des relations entre segments (dans le cas où une courbe est donnée).

Un résultat obtenu par le calcul algébrique peut-il être considéré comme démontré ? Descartes répond oui. Il écrit qu'il y a deux façons de démontrer, l'une par l'analyse et l'autre par la synthèse : *L'analyse montre la vraie voie par laquelle une chose a été méthodiquement inventée [...] ; en sorte que si le lecteur la veut suivre, et jeter les yeux soigneusement sur tout ce qu'elle contient, il n'entendra pas moins parfaitement la chose ainsi démontrée, et ne la rendra pas moins sienne, que si lui même l'avait inventée [...]. La synthèse, au contraire, par une voie toute autre [...] démontre à la vérité clairement ce qui est contenu en ces conclusions, et se sert d'une longue suite de définitions, d'axiomes, de théorèmes et de problèmes, [...] elle arrache le consentement du lecteur [...], mais ne donne pas, comme l'autre, une entière satisfaction aux esprits⁸. La satisfaction de l'esprit vient de la démarche méthodique du géomètre qui décompose la figure en éléments simples et manipule les symboles algébriques représentant ces éléments. La figure n'est pas seulement contemplée, elle est disséquée en un calcul. L'évidence visuelle se poursuit en une évidence calculatoire. Pour Descartes, l'évidence assure la vérité des résultats obtenus, ce qui légitime le caractère démonstratif du calcul.*

L'évidence ne repose pas sur la déduction logique de propositions à partir d'axiomes, mais elle se fonde sur la manipulation des objets simples représentés par des symboles. La métaphore de la contemplation ou de la vue est remplacée par celle du toucher. Ainsi, Descartes distingue comprendre et savoir dans une lettre à Mersenne de mai 1630 en écrivant que *comprendre c'est embrasser de la pensée [c'est-à-dire prendre dans ses bras] ; mais pour savoir une chose, il suffit de la toucher de la pensée⁹. La rupture cartésienne est suffisamment importante pour que la plupart de ses contemporains ne comprennent pas *La géométrie*. Mais Descartes va avoir des disciples, comme Arnauld ou Lamy. Dans *La logique ou l'art de penser*, écrit avec Nicolle en 1662, le premier reproche aux géomètres comme Euclide d'avoir *plus de soin de la certitude que de l'évidence, et de convaincre l'esprit que de l'éclairer*. Il reproche, en particulier, à Euclide d'avoir démontré la proposition 20 du livre I, qui n'a pas besoin de preuve, et d'avoir démontré la proposition 1 qui n'est qu'un cas particulier de la proposition 22. Arnauld n'est plus du tout sensible à l'ordre logique des *Eléments*, et il prône un ordre naturel qui concerne plus l'évidence des objets que des propositions¹⁰.*

Lamy, consacre un chapitre de ses *Eléments de géométrie* à la méthode cartésienne. Il résout, à l'aide de cette méthode, un certain nombre de problèmes du type de celui de la proposition du Livre II d'Euclide. Il faut supposer le problème résolu, donner des noms aux segments connus et inconnus : ici $AB = a$ et

⁷ DESCARTES, *Discours de la méthode*, Fayard, p.335.

⁸ DESCARTES, *Œuvres et lettres*, La Pléiade, p.279.

⁹ DESCARTES, *Lettres*, PUF, p.12.

¹⁰ ARNAULD et NICOLE, *La logique ou l'art de penser*, PUF, pp.326-331.

AH = x, parcourir le problème pour établir des relations entre connus et inconnus : ici $x^2 = (x - a)^2$, et enfin résoudre l'équation. Ici on obtient deux solutions :

$$-\frac{1}{2}a + \frac{\sqrt{5}}{2}a \text{ et } -\frac{1}{2}a - \frac{\sqrt{5}}{2}a.$$

La première solution est possible puisque l'inconnue cherchée est un segment. Mais la seconde solution est pourtant tout aussi légitime d'un point de vue algébrique. Alors, quel peut être son statut géométrique ? Ce type de question va devenir insistant au 19^{ème} siècle.

Lamy résout d'autres problèmes, de la façon aveugle que permet le calcul algébrique. Ainsi, il demande de trouver¹¹ le point F du côté CB d'un carré donné de telle sorte que le segment FE soit également donné (fig.4). Il nomme AB = a, FE = b, AF = x, et CF = z, il parcourt le problème en écrivant un certain nombre de relations déduites de propriétés de similitude et du théorème de Pythagore, et il obtient finalement une équation (1) du quatrième degré que doit satisfaire x :

$$x^2 (b + x)^2 = a^2 [(b + x)^2 + x^2].$$

Ainsi la mise en équation échoue par manque de simplicité, et Lamy doit reprendre le problème en faisant une construction géométrique supplémentaire (fig.5). Il mène du point E la perpendiculaire à AE et la parallèle à AD qui coupent le prolongement de AB respectivement en H et G, et il démontre que EG = x. Puis il nomme BG = y, et en parcourant de nouveau le problème, il obtient cette fois une équation (2) du second degré que doit satisfaire y :

$$y^2 = a^2 + b^2.$$

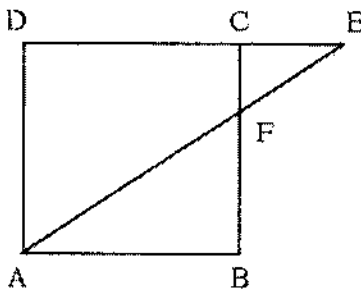

fig.4

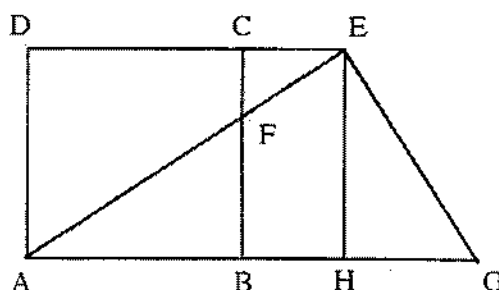

fig.5

La critique cartésienne des Anciens peut ici s'appliquer : comment Lamy a-t-il découvert la construction ? Le géomètre a-t-il contemplé la figure ou l'algébriste a-t-il pu être guidé par le calcul ? Lamy n'en dit rien, mais il faut remarquer qu'il a mené jusqu'au bout la mise en équation infructueuse. Or si nous prenons pour nouvelle variable t, car il s'agit maintenant d'un calcul purement algébrique, avec

$$t^2 = (b + x)^2 + x^2, \text{ c'est-à-dire encore } t^2 = 2x(x + b) + b^2,$$

alors l'équation (1) devient : $x(b + x) = at$. Par conséquent t vérifie l'équation

$$t^2 = 2at + b^2,$$

qui, par un nouveau changement de variable $y = t - a$, redonne l'équation (2) de Lamy. Mais quel statut géométrique donner alors à t et à y ? On peut remarquer que t est l'hypothénuse d'un triangle rectangle de côté (b + x) et x, comme le triangle AEG construit par Lamy. Cet exemple, donné cependant par un admirateur de Descartes, montre bien les difficultés que rencontre le géomètre aux prises avec le calcul algébrique, même si le maître a consacré un livre entier de sa *Géométrie* au travail sur les équations. Plus d'un siècle plus tard, Gergonne va proposer à ses

¹¹ LAMY, *Eléments de géométrie*, seconde édition, 1695, pp. 351-353.

contemporains des problèmes de géométrie où il s'avère que le raisonnement sur les figures l'emporte dans la simplicité sur le calcul analytique.

Calcul analytique et géométrie pure : une évidence partagée

Les travaux de Desargues, Pascal ou La Hire sur la géométrie perspective ne rencontrent que peu d'écho au 18^{ème} siècle, tandis que la méthode cartésienne étendue en un calcul analytique et infinitésimal se révèle toute puissante. Cependant à la fin du siècle, les leçons de Monge vont redonner de l'intérêt pour des méthodes purement géométriques, et donner naissance à ce que l'on appellera plus tard la géométrie moderne. En tant qu'éditeur des *Annales de mathématiques pures et appliquées*, Gergonne propage les nouvelles idées, qui se heurtent aux habitudes des analystes. Dans le premier tome, paru en 1810-1811, il propose aux lecteurs plusieurs problèmes de minima, par exemple, de déterminer, sur un plan, un point dont la somme des distances à trois points, ou généralement à un nombre quelconque de points, soit un minimum¹².

Un correspondant de l'Institut, nommé Tédénat, présente deux méthodes de résolution¹³. La première passe par un calcul analytique, où le système de points est rapporté à deux axes rectangulaires : les points donnés m, m', m'', \dots de coordonnées $(\alpha, \beta), (\alpha', \beta'), (\alpha'', \beta''), \dots$ et le point M cherché de coordonnées (x, y) . Alors la somme S des distances z, z', z'', \dots des points donnés au point M s'exprime algébriquement, et la condition de minimalité de S s'exprime en écrivant que les dérivées de S par rapport à x et y sont nulles. Tédénat obtient deux équations :

$$\frac{x - \alpha}{\sqrt{(x - \alpha)^2 + (y - \beta)^2}} + \frac{x - \alpha'}{\sqrt{(x - \alpha')^2 + (y - \beta')^2}} + \frac{x - \alpha''}{\sqrt{(x - \alpha'')^2 + (y - \beta'')^2}} + \dots = 0,$$

$$\frac{y - \beta}{\sqrt{(x - \alpha)^2 + (y - \beta)^2}} + \frac{y - \beta'}{\sqrt{(x - \alpha')^2 + (y - \beta')^2}} + \frac{y - \beta''}{\sqrt{(x - \alpha'')^2 + (y - \beta'')^2}} + \dots = 0,$$

ce qui, écrit-il, *théoriquement parlant, suffit pour la détermination de ce point ; mais malheureusement ces équations, par leur extrême complication, ne peuvent être, dans le plus grand nombre des cas, d'un grand secours pour la résolution complète du problème.* Il nomme alors a, a', a'', \dots les angles des droites $mM, m'M, m''M, \dots$ et remarque que les équations prennent une forme très simple :

$$\cos a + \cos a' + \cos a'' + \dots = 0 \quad \text{et} \quad \sin a + \sin a' + \sin a'' + \dots = 0.$$

Il fait remarquer que lorsqu'une droite coupe un polygone régulier alors les angles faits par cette droite et les côtés du polygone vérifient les équations précédentes. Le reste du raisonnement est géométrique : les droites $mM, m'M, m''M, \dots$ doivent être parallèles aux côtés d'un tel polygone, donc, par exemple pour trois points, les angles mMm' et $m'Mm''$ doivent être égaux à 120° . Dans la deuxième solution, Tédénat note a, b, c, \dots les distances des points donnés au point cherché, A, B, C, \dots les angles $mMm', m'Mm'', \dots$, et P l'aire du polygone dont les sommets sont les points donnés. Alors il obtient trois équations :

$$a + b + c + \dots = \text{minimum},$$

$$A + B + C + \dots = 360^\circ,$$

¹² *Annales de mathématiques pures et appliquées*, tome 1, 1810-1811, p.196.

¹³ *op.cit.*, pp.285-291.

$$ab \sin A + bc \sin B + cd \sin C + \dots = 2P.$$

En considérant que a, b, c, \dots sont *des variables absolument indépendantes*, il dérive les trois équations par rapport à a, b, c, A, B, C, \dots et obtient un système d'équations différentielles qu'il résoud en trois pages de calcul sans aucune figure. Cependant, il est clair que les calculs, en particulier les changements de variables, sont conduits par la forme des expressions : la vision guide la manipulation.

Gergonne présente, de manière anonyme, une construction géométrique *fort simple*, dont il écrit qu'il *sera facile, pour tout lecteur intelligent, de suppléer à ce qu'il aura volontairement omis*. Sa solution repose sur deux lemmes géométriques, qui servent à la résolution de nombreux problèmes de minima¹⁴. Le premier indique que le point M d'une droite donnée AB dont la somme des distances à deux points donnés P et Q , situés d'un même côté de AB , est minimale, est tel que les angles AMP et QMB sont égaux (fig.6). En effet, soit P' le point tel que PP' est perpendiculaire à AB et $CP = CP'$, alors si $MP + MQ$ est minimum, il en est de même de $MP' + MQ$, donc M, P', Q doivent être alignés. Le second lemme indique que le point M d'une circonférence donnée de centre O dont la somme des distances à deux points donnés P et Q , tels que MP et MQ ne coupent pas la circonférence, est minimale, est tel que les angles OMP et OMQ sont égaux (fig. 7). En effet, si on considère un autre point N de la circonférence et si NQ rencontre en D la tangente menée du point M à la circonférence alors

$$MP + MQ < DP + DQ, \text{ d'après le premier lemme,}$$

$$\text{et } DP + DQ < NP + NQ,$$

$$\text{donc } MP + MQ < NP + NQ.$$

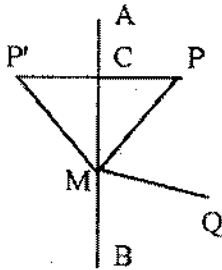

fig. 6

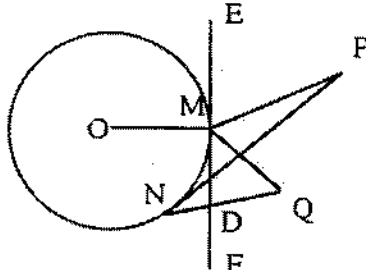

fig.7

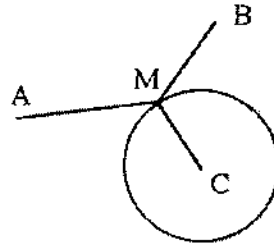

fig.8

Les raisonnements de Gergonne se voient sur les figures, comme celui de la construction du point M dont la somme des distances à trois points donnés A, B, C soit minimale (fig.8). Il suppose que la distance MC est donnée, et il considère le point M de la circonférence de centre C et de rayon MC tel que $MA + MB$ soit minimale, d'après le deuxième lemme les angles CMA et CMB sont égaux. Ainsi, les trois angles CMA, AMB et BMC sont égaux et valent 120° .

Dans son journal, Gergonne promeut les travaux de Monge, mais aussi la théorie des transversales de Carnot, qui écrit en 1806 qu'il a voulu *libérer la géométrie des hiéroglyphes de l'algèbre*, et la théorie des pôles et polaires qui fait suite au mémoire de Brianchon de 1806. Il publie en 1817-1818 l'un des premiers mémoires de Poncelet, qui fut élève de Monge. Poncelet explique qu'à l'époque où il était élève de l'Ecole polytechnique, de 1808 à 1810, il avait voulu trouver par l'analyse la courbe dont le rayon de courbure en un point quelconque est double de la normale par rapport à l'axe des abscisses, et qu'il avait été fort surpris d'obtenir l'équation de la parabole, au lieu de la cycloïde attendue. Comprenant que ce

¹⁴ op. cit., pp. 375-384.

résultat était du à une influence du signe +, il avait cherché une démonstration purement géométrique des principales propriétés de la parabole, une démonstration débarrassée de tout appareil algébrique¹⁵. Alors qu'il est en captivité dans les prisons russes de Saratoff, réduit à ses souvenirs de lycéen et d'élève de l'Ecole polytechnique, où il a cultivé avec prédilection les ouvrages de Monge, de Carnot et de Brianchon, il rédige plusieurs cahiers consacrés à la nouvelle géométrie.

Le troisième cahier concerne les propriétés descriptives des coniques et les premiers principes de projection. Selon le quatrième principe, si on se donne une conique et une droite sur un même plan, alors il existe une infinité de manières de projeter la figure sur un nouveau plan de sorte que sa projection soit un cercle et que la droite se projette à l'infini. Examinant les cas où la démonstration géométrique du principe se heurte à des impossibilités, il remarque que l'analyse permet cependant de conclure et il écrit : *C'est cette grande généralité de l'analyse, qu'on doit pouvoir procurer dans les mêmes circonstances aux démonstrations de la géométrie, qui a justifié cette expression de puissance de l'analyse. [...] Dans le cours d'un calcul, il arrive souvent que certaines expressions qui y entrent implicitement, sont nulles, infinies, imaginaires, ou prennent tout autre forme : on continue le calcul sans s'en douter [...]. Il n'en est pas de même de la géométrie, telle qu'on a coutume de la considérer ; comme tous les raisonnements, toutes les conséquences, ne peuvent être appréciés, saisis par l'esprit qu'autant qu'ils se peignent à l'imagination par des objets sensibles, dès que ces objets manquent, le raisonnement s'arrête*¹⁶. L'analyse et la géométrie se différencient dans la pratique du mathématicien car l'évidence se fonde, selon le cas, sur la manipulation aveugle de symboles ou sur l'imagination visuelle. Si l'analyse se montre toute puissante, la géométrie lui est supérieure du point de vue de la simplicité et de l'élégance et elle peut s'en faire l'égale à condition d'adopter de nouveaux principes. Poncelet examine un peu plus loin un problème, où géométrie pure et analyse sont encore confrontés. Etant données dans un plan deux droites AM et AN, une conique et une tangente X'X'', le problème consiste à chercher le lieu du point P, intersection de deux autres tangentes PX' et PX'' quand la tangente X'X'' varie (fig.9).

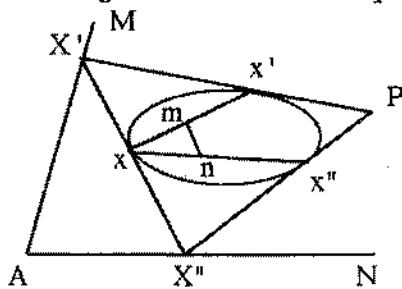

fig.9

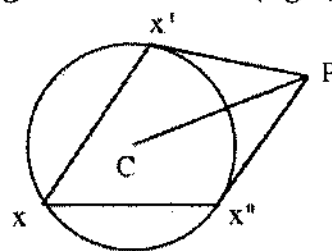

fig.10

Poncelet débute par une *solution purement géométrique*. Quand X'X'' varie, la corde xx' est assujettie à passer par un point fixe m (le pôle de AM) et la corde xx'' est assujettie à passer par un point fixe n (le pôle de AN). D'après le quatrième principe, il existe une projection telle que le projeté de la conique soit un cercle et que la droite mn se projette à l'infini. Par conséquent, on est ramené au problème suivant : étant donné un cercle, un point x de ce cercle et deux cordes xx' et xx'' parallèles à des directions données, trouver le lieu du point du point P, intersection

¹⁵ PONCELET, *Applications d'analyse et de géométrie*, éd. 1862, pp.462-468.

¹⁶ op.cit., pp.124-125.

des tangentes Px' et Px'' quand x parcourt la circonférence (fig.10). Il est clair, écrit Poncelet, que l'angle $x'xx''$ est constant, donc la corde $x'x''$ est constante et par conséquent le point P est à une distance constante du centre C du cercle. Ainsi, P parcourt un cercle concentrique au premier, et le point P du problème initial parcourt une conique. Il commente ainsi la solution : *Si l'on voulait traiter la même question dans toute sa généralité par l'analyse des coordonnées, on serait jeté dans des calculs ou éliminations d'une longueur rebutante*¹⁷. Il poursuit cependant par trois longues solutions analytiques, non pour donner à la première démonstration une plus grande certitude, mais pour préciser exactement le lieu et pour montrer comment des solutions étrangères à la question s'infiltrèrent dans les calculs.

Dans une note à propos de la construction du lieu, Poncelet oppose encore les ressources de l'analyse algébrique à l'usage du raisonnement géométrique, où on se livre à la contemplation intime, intuitive pour ainsi dire, des conditions et des données de chaque problème¹⁸. Ce genre de solutions, écrit-il, mérite seul les épithètes d'élégant, rapide, ingénieux. L'évidence visuelle, à laquelle il invite le mathématicien, est une évidence dans l'espace, et non dans le plan. Or, le géomètre peut contempler une figure du plan comme une image qui est devant lui, alors qu'il est lui-même dans l'espace où se trouve la figure. Autrement dit, dans l'espace, image et figure ne coïncident plus : l'évidence visuelle dans le plan et dans l'espace sont bien différentes. Chasles rapporte que dans ses cours, Monge ne dessinait pas de figures, mais qu'il savait faire concevoir dans l'espace toutes les formes les plus compliquées de l'étendue [...] sans autre secours que celui de ses mains, dont les mouvements secondaient admirablement sa parole¹⁹. Dans l'espace, l'évidence visuelle a besoin du secours du mouvement et de la langue. Tout comme la nouvelle géométrie a besoin de nouveaux principes pour prétendre égaler la puissance de l'analyse. Dans les années 1820, Poncelet et Gergonne vont proposer, l'un le principe de continuité et l'autre le principe de dualité. Ceci va occasionner une querelle entre les deux mathématiciens, mais au-delà de simples polémiques ou de disputes de paternité leurs différents sont profonds. En effet, d'une certaine façon, le principe de continuité ressort d'une évidence du mouvement et le principe de dualité d'une évidence de la langue.

Questions de principes : une querelle d'évidence

Dans son *Traité des propriétés projectives des figures* de 1822, Poncelet se propose de rendre la géométrie descriptive indépendante de l'analyse algébrique. Quelle est la puissance extensive de l'analyse algébrique ? Pourquoi la géométrie ancienne en est privée et quel moyen mettre en usage pour qu'elle en jouisse ? Poncelet explique que l'algèbre représente les grandeurs par des signes abstraits qui laissent à ces grandeurs toute l'indétermination possible, le raisonnement y est implicite et fait abstraction de la figure, tandis que la géométrie ancienne ne tire jamais de conséquences qui ne puissent se peindre à l'imagination ou à la vue. Mais s'il était possible d'y appliquer un raisonnement implicite, en faisant abstraction de la figure, la géométrie ancienne deviendrait la rivale de la géométrie analytique. Il énonce ensuite son principe de continuité. Considérons une figure quelconque, dans

¹⁷ op.cit., p.145.

¹⁸ op.cit., p.151.

¹⁹ CHASLES, *Aperçu historique des méthodes en géométrie*, p.209.

une position générale et en quelque sorte indéterminée, et supposons qu'on est trouvé des relations ou des propriétés, soit *métriques*, soit *descriptives*, de la figure par un raisonnement explicite ordinaire. Alors, écrit Poncelet, *n'est-il pas évident que si, en conservant ces mêmes données, on vient à faire varier la figure primitive par degrés insensibles, ou qu'on imprime à certaines parties de cette figure un mouvement continu d'ailleurs quelconque, n'est-il pas évident que les propriétés et les relations, trouvées pour le premier système, demeureront applicables aux états successifs de ce système, pourvu qu'on ait égard aux modifications particulières qui auront pu y survenir [...] modifications qu'il sera toujours aisé de reconnaître a priori, et par des règles sûres ?*²⁰.

Pour Poncelet, le principe de continuité est une sorte d'axiome dont *l'évidence est manifeste, incontestable et n'a pas besoin d'être démontré*. S'il n'est pas admis comme moyen de démonstration, il doit l'être au moins comme moyen de découverte et d'invention. Il lui semble irraisonnable de repousser, en géométrie, des notions généralement admises en algèbre. Cependant, il va en être de l'évidence du principe de continuité comme de l'évidence cartésienne : elle ne va pas emporté l'adhésion de tous les contemporains. La géométrie de Poncelet sera même qualifiée par certains Académiciens de *géométrie romantique*. Dans un rapport à l'Académie Royale des Sciences de janvier 1826, Cauchy écrit que le principe de continuité *n'est qu'une forte induction*²¹. Poncelet répliquera plus tard en écrivant que Cauchy ne possédait qu'imparfaitement le sentiment de la véritable géométrie. Dans un autre rapport à l'Académie sur un mémoire de Gergonne relatif à la théorie des polaires réciproques, les rapporteurs expliquent que pour mettre le résultat *hors de doute, il leur paraît nécessaire de substituer à la démonstration géométrique de M. Poncelet une démonstration analytique*²². En 1827, Poncelet dénonce *l'habitude généralement acquise d'accorder à l'algèbre une rigueur presque indéfinie*, accuse les Rapports faits à l'Académie d'avoir jeté une sorte de défaveur sur ses principes, et regrette que le reproche de manque de rigueur ait été reproduit par plusieurs géomètres, et par Gergonne lui-même²³. Ce dernier a énoncé l'année précédente son principe de dualité, et les deux mathématiciens sont maintenant en conflit.

Dans ses *Considérations philosophiques sur les éléments de la science de l'étendue*²⁴ de 1826, Gergonne range en deux catégories les théories de la science de l'étendue : celles qui concernent les relations métriques sont établies par le calcul, celles qui concernent la situation des êtres géométriques peuvent être déduites du calcul mais peuvent aussi en être *dégagés complètement*. Il en prend pour témoin les travaux de Monge, qui laissent à penser que la division de la géométrie en géométrie plane et géométrie de l'espace n'est pas aussi naturelle *que vingt siècles d'habitude ont pu nous le persuader*. Il remarque, que dans la géométrie plane, à chaque théorème répond un autre qui s'en déduit en échangeant simplement entre eux les deux mots points et droites, tandis que dans la géométrie de l'espace ce sont les mots points et plans qu'il faut échanger. *Cette sorte de dualité des théorèmes constituent la géométrie de situation*. Gergonne dispose les théorèmes duaux en

²⁰ PONCELET, *Traité des propriétés projectives des figures*, tome 1, introduction, p.XIII.

²¹ op.cit., tome 2, introduction, p.356.

²² op.cit., p.361.

²³ GERGONNE, note dans le tome VII du *Bulletin de Férussac*, 1827, pp.109-117.

²⁴ GERGONNE, *Considérations philosophiques sur les éléments de la science de l'étendue, Annales de mathématiques pures et appliquées*, tome XVI, n°6, janvier 1826, pp.209 et suivantes.

colonnes, car, écrit-il, il est *superflu d'accompagner ce mémoire de figures, souvent plus embarrassantes qu'utiles, dans la géométrie de l'espace [...]. Il ne s'agit ici, en effet, que de déductions logiques, toujours faciles à suivre, lorsque les notations sont choisies de manière convenable.*

La dualité est manifeste dans l'énoncé du théorème de Desargues et de sa réciproque, et la disposition en colonnes permet de la mettre en évidence :

Théorème de Desargues

Si deux triangles sont tels que les *droites* joignant les sommets correspondants passent par un même *point* O, alors les côtés correspondants s'intersectent en trois *points* alignés.

Dual du théorème de Desargues

Si deux triangles sont tels que les *points* de rencontre des côtés correspondants appartiennent à une même *droite* O, alors les sommets correspondants sont joints par trois *droites* concourantes.

On peut aussi mettre en dualité le théorème de Pascal et le théorème de Brianchon. Le rapporteur du mémoire de Gergonne dans le *Bulletin des sciences de Férussac* note que les propriétés de pôles et polaires mettent également en évidence la dualité²⁵. Mais Gergonne étend de manière beaucoup plus générale la dualité à toute la science de l'étendue. Sa dualité consiste en un véritable travail de traduction, un travail sur la langue, comme l'indique le premier exemple de son mémoire de 1826, qui met en dualité des propositions du plan et de l'espace :

Deux points, distincts l'un de l'autre, donnés dans l'espace, déterminent une droite indéfinie qui, lorsque ces deux points sont désignés par A et B, peut être elle-même désignée par AB

Deux plans, non parallèles, donnés dans l'espace, déterminent une droite indéfinie qui, lorsque ces deux plans sont désignés par A et B, peut être elle-même désignée par AB.

Dans une note²⁶ de mars 1827 sur un mémoire de Poncelet, Gergonne écrit que certains énoncés de théorèmes sont susceptibles de *l'espèce de traduction* qui fait le sujet de méditations de Poncelet, sans que leurs auteurs aient l'air de se douter que cette traduction soit possible. Il reproche à Poncelet de brusquer les révolutions, alors que lui-même essaie de rendre la vérité sensible. Car l'obstacle à la propagation facile des doctrines que, lui-même et Poncelet, veulent populariser réside dans l'obligation de parler la langue créée pour une géométrie plus restreinte. Or, quand *la langue d'une science est bien faite, les déductions logiques y deviennent d'une telle facilité, que l'esprit va pour ainsi dire de lui-même au devant des vérités nouvelles.* C'est par un travail sur la langue, que les nouvelles doctrines peuvent être rendues évidentes : il est nécessaire, pour présenter la nouvelle théorie sous le jour le plus avantageux, de créer d'abord *une langue à sa taille.*

Cette note est à l'origine de la querelle entre les deux mathématiciens. Poncelet est furieux de lire dans un *Bulletin des sciences de Férussac* qu'il aurait repris les recherches sur la dualité de Gergonne. Poncelet va s'efforcer de montrer que son idée de réciprocity n'est pas celle de dualité, et expliquer qu'il est même opposé à cette dernière, en particulier à la mise en colonnes des propositions. Il va reprocher à Gergonne d'avoir érigé en principes généraux des propositions fausses

²⁵ PONCELET, op.cit., p.382.

²⁶ op.cit., pp.390-393.

et d'avoir ensuite *torturer le sens des mots* pour en rectifier les conséquences²⁷. La querelle va englober aussi Plücker, qui annonce *avoir découvert de manière purement analytique le secret de la dualité*. La vivacité des propos de Poncelet indique la profondeur des désaccords : ces sont trois conceptions de l'évidence qui sont confrontés, ancrées dans des pratiques et des habitudes différentes. La querelle des évidences sera toujours vivace à la fin du 19ème siècle. Hadamard se fera qualifié de traître par Hermite parce que, dans un mémoire de 1898, le premier a utilisé les intuitions géométriques et que le second méprise la géométrie. Hermite apostrophe Hadamard en s'écriant : "Vous avez trahi l'analyse pour la géométrie"²⁸.

Evidence logique, évidence visuelle et évidence manipulatoire

La lecture de Poincaré des *Fondements de la géométrie* d'Hilbert, parus en 1899, peut servir d'épilogue à notre historique. Dans cet ouvrage les choses de la géométrie sont définies de manière purement grammaticale selon un jeu de langage proche de celui que proposait Gergonne. Ainsi, les premiers axiomes énoncent : 1. Il existe une droite liée à deux points donnés A et B à laquelle appartiennent ces deux points, 2. Il n'existe pas plus d'une droite à laquelle appartiennent deux points A et B, 3. Sur une droite, il y a au moins deux points ; il existe au moins trois points non alignés, 4. Il existe un plan lié à trois points non alignés A, B, C auxquels appartiennent ces trois points A, B, C. Cette géométrie est axiomatique, comme celle des anciens, mais ici aucune évidence visuelle n'est supposée.

L'assemblage logique et visuel de la géométrie d'Euclide a explosé avec l'invention des géométries non euclidiennes. En 1733, lorsqu'il se trouve confronté au choix entre le discours logique et l'évidence visuelle, Saccheri écrit que la nature de la ligne droite répugne à l'hypothèse non euclidienne et il choisit donc l'évidence visuelle. Les inventeurs de la géométrie non euclidienne font le choix inverse. Attaché à la vision de la géométrie, Poincaré proposera cependant un modèle visuel de la géométrie hyperbolique.

Dans *Science et méthode* de 1909, Poincaré oppose deux types de définitions mathématiques : *celles qui cherchent à faire naître une image, et celles où on se borne à combiner des formes vides, parfaitement intelligibles, mais purement intelligibles, que l'abstraction a privé de toute matière*²⁹. Ces dernières définitions sont celles de la géométrie hilbertienne, mais aussi celles de la géométrie analytique, telle que la lisent les géomètres du 19ème siècle. Poincaré remarque que les définitions qui sont le mieux comprises des uns ne seront pas celles qui conviendront aux autres.

Les étapes historiques que nous avons évoquées sont là pour nous convaincre de la justesse du propos. A chaque étape, une nouvelle évidence fabriquée par un mathématicien s'est trouvée confrontée aux habitudes de l'évidence acquise par ses contemporains. Autrement dit, et paradoxalement, l'évidence peut ne pas être évidente. Le sentiment, pourtant si intime de l'évidence, doit être compris beaucoup plus comme un *habitus*, une structure structurée qui fonctionne comme une structure structurante³⁰, que comme une innéité.

²⁷ op.cit., p.374.

²⁸ rapporté par S. MANDELBROT dans *Cahiers du séminaire d'histoire des mathématiques*, IHP, t.6, 1985, pp.1-46.

²⁹ POINCARÉ, *Science et méthode*, 1909, p.127.

³⁰ je reprends la définition d'*habitus* proposée par BOURDIEU dans *Le sens pratique*, Editions de minuit, 1980, p.88.

QU'EST-CE QUE L'ALGÈBRE ? UN DOMAINE OU UN LANGAGE ?

Jean-Paul Guichard, IREM de Poitiers, France

Qu'y a-t-il de commun entre l'*Algebra* de Bombelli (1572), les *Elémens d'Algèbre* de Clairaut (1768) et l'*Algebra* de Lang (1969) ? La comparaison du contenu de ces deux derniers ouvrages est éloquente.

1768. Clairaut. Elémens d'Algèbre.	1969. Lang. Algebra.
1. De la méthode algébrique d'exprimer les problèmes par des équations, et de la résolution des équations du 1 ^{er} degré	1. Groups, Rings, and Modules Groups-Rings-Modules-Homology-Polynomials-Noetherian Rings and Modules
2. Résolution des équations du 2 ^e degré	2. Field theory Algebraic Extensions-Galois Theory-Extensions of Rings-Transcendental Extensions-Real Fields-Absolute Values
3. Principes généraux pour les équations de tous les degrés	
4. Résolution des équations de degré quelconque quand elles n'ont que deux termes	3. Linear Algebra and Representation Matrices and Linear Maps-Structure of Bilinear forms-Representation of One Endomorphism-Multilinear Products-Semi-simplicity-representations of Finite Groups
5. Résolution des équations du 3 ^e et 4 ^e degré	

D'où une première question : comment le mot Algèbre en est arrivé à désigner des contenus aussi différents ?

Si l'on regarde maintenant ce qui se passe au niveau de l'enseignement secondaire, tout du moins en France, on peut constater que l'algèbre est un domaine aux contours incertains qui tend à se dissoudre.

Au collège les mots algèbre et algébrique ont complètement disparu des programmes, même si la partie des programmes intitulée "Travaux numériques" correspond pour une bonne part à celle qui dans les années 1960 s'intitulait "Arithmétique et Algèbre".

Au lycée, en terminale scientifique, le contenu d'un manuel d'algèbre des années 1960 se retrouve dans le manuel d'analyse des années 1990, et le seul chapitre, celui sur les complexes, rescapé du manuel d'arithmétique de 1960, apparaît comme un chapitre d'algèbre dans le manuel de géométrie de 1990!

D'où une deuxième question : pourquoi le mot Algèbre ne désigne-t-il plus, au niveau de l'enseignement secondaire, un ensemble de contenus ?

Il nous semble que des éléments de réponse à ces deux questions peuvent se trouver en considérant l'histoire des mathématiques.

Le domaine des équations

L'origine et l'emploi du mot Algèbre vont nous servir de guide. C'est Al Khwarizmi, mathématicien à Bagdad au 9^e siècle, qui va faire école. En effet, il publie un ouvrage sur les équations du premier et du second degré, avec des applications à des problèmes de géométrie et d'héritages, qu'il intitule *Court traité*

sur le calcul d'al-jabr et al-muqabala. Ces deux termes désignent deux transformations de base des équations, al-jabr étant celle qui permet de "restaurer" l'équation en supprimant les soustractions. Le terme Algèbre va dès lors désigner le domaine des équations. Mais il faut remarquer qu'à cette époque le traitement des équations se fait sans aucun symbole. Tout s'exprime dans le langage ordinaire comme on peut en juger par le problème suivant où Al Khwarizmi donne la méthode pour résoudre l'équation $x^2 + a = bx$.

Quant aux carrés et au nombre qui égalent des racines, c'est comme quand tu dis : un carré et vingt et un en nombre égalent dix de ses racines. Cela vaut aussi pour tout bien qui est tel que si on lui ajoute vingt et un dirhams, la somme qui en résulte est égale à dix racines de ce bien.

La méthode de résolution consiste en ceci : prends la moitié des racines, cela fera cinq ; tu la multiplies par elle-même, cela fera vingt-cinq ; tu retranches les vingt et un dont on a dit qu'ils étaient avec les carrés, il restera quatre ; tu prends sa racine qui est deux ; tu la retranches de la moitié des racines qui est cinq. Il restera trois et c'est la racine du carré que tu voulais et le carré est neuf.

Il faut noter qu'Al Khwarizmi démontre la validité de tous ses algorithmes en utilisant la géométrie d'Euclide.

Si son traité marque la naissance d'une nouvelle discipline, est-ce à dire qu'auparavant la notion d'équation était inconnue des mathématiciens ? En fait la recherche d'un nombre ou d'une quantité inconnue se rencontre dès les débuts de l'histoire des mathématiques ; et lorsqu'il s'agit d'équations du second degré on remonte généralement aux babyloniens. Peut-on alors, même s'il y a anachronisme, parler d'algèbre ? Examinons trois types de résolutions différents.

Babylone. Tablette BM 13901 Problème 2. 1800 avant J.C.

J'ai soustrait de la surface le côté de mon carré : 14'30. Tu poseras 1, l'unité . Tu fractionneras en deux 1 : (30'). Tu croiseras 30' et 30' : 15'. Tu ajouteras à 14'30 : 14'30°15'. C'est le carré de 29°30'. Tu ajouteras le 30' que tu as croisé à 29°30' : 30 le côté du carré.

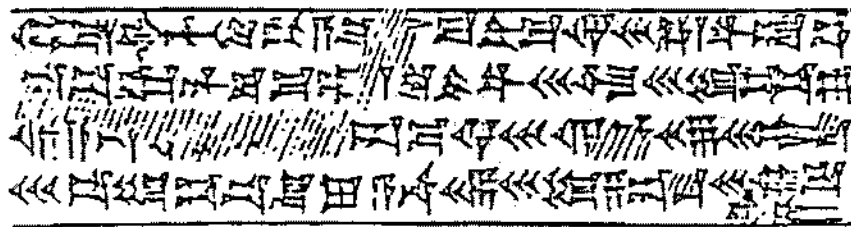

Il s'agit de résoudre une équation du type $x^2 - x = a$. On peut remarquer que l'algorithme qui donne la solution est le même que celui qu'utilise Al Khwarizmi dans le problème voisin que nous avons donné en exemple, et que la présentation de la méthode à suivre est très similaire. C'est pourquoi de nombreux auteurs parlent d'algèbre babylonienne ; ces problèmes babyloniens figurent d'ailleurs toujours dans l'histoire de l'algèbre. Mais quelle est la rupture qu'a introduite

Al Khwarizmi, et qui a été reconnue comme telle par ses successeurs dans leur emploi du nom d'algèbre pour leurs traités ? C'est certainement le fait d'avoir inversé l'ordre ancien problèmes-équations, en faisant des équations le point de départ et l'objet d'une étude mathématique. Nous allons pouvoir le vérifier sur deux autres types de résolution.

Euclide. Les Eléments, livre II, proposition 11. 3^e siècle avant J.C.

Couper une droite de telle sorte que le rectangle contenu par la droite entière et l'un des segments soit égal au carré sur le segment restant.

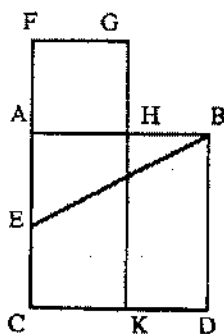

Soit la droite donnée AB. Il faut alors couper la droite AB de telle sorte que le rectangle contenu par la droite entière et l'un des segments soit égal au carré sur le segment restant.

En effet, que le carré ABCD soit décrit sur AB. Et que AC soit coupée en deux parties égales au point E. Que BE soit jointe, et que CA soit conduite jusqu'en F ; et que soit placée EF égale à BE, et que le carré FH soit décrit sur AF ; et que GH soit conduite jusqu'en K. Je dis que AB a été coupée en H de façon à rendre le rectangle contenu par AB, BH égal au carré sur AH.

Il s'agit de résoudre l'équation $cx = (c - x)^2$ qui peut se ramener au type $x^2 + a = bx$ d'Al Khwarizmi. Nous voyons immédiatement que le problème d'Euclide est de construire géométriquement des grandeurs qui sont en fait solutions d'équations, et non de traiter de la résolution des équations. Dans sa démonstration Euclide utilise des transformations d'aires que nous pouvons lire comme des transformations d'expressions algébriques. C'est ce qui a fait dénommer, à la suite de Paul Tannery (19^es.), ces méthodes euclidiennes d'*algèbre géométrique*. D'ailleurs Al Khwarizmi ne s'y est pas trompé : il a su interpréter algébriquement des résultats géométriques d'Euclide, et ainsi pu démontrer la validité de tous ses algorithmes de résolution des équations par des méthodes géométriques puisées dans les Eléments d'Euclide. Le cas de Diophante est différent.

Diophante. Les Arithmétiques, livre I, problème 27. 3^e siècle.

Il s'agit de résoudre le système $x + y = b$ et $xy = a$ qui peut se ramener aussi à l'équation $x^2 + a = bx$ d'Al Khwarizmi. La grande innovation de Diophante est l'utilisation explicite d'"un nombre qui possède en soi une quantité indéterminée d'unités", noté S , et dénommé "arithme" dans la traduction française de Ver Eecke (1925), et d'un calcul avec cette inconnue, comme on peut en juger dans le texte qui suit. Au début de son ouvrage Diophante explique comment se font les calculs avec l'arithme, son inverse, leurs puissances, leurs produits et les expressions additives et soustractives que l'on peut former avec ces nombres d'une nouvelle espèce. D'autre part les deux règles d'*al-jabr et al-muqabala* d'Al Khwarizmi y figurent comme méthode pour transformer les équations. On comprend que Diophante ait pu être appelé le père de l'algèbre.

Trouver deux nombres tels que leur somme et leur produit forment des nombres donnés.

Proposons que la somme des nombres soit $\overline{\text{K}}$ (20 unités), et que leur produit soit $\overline{\text{Q}\overline{5}}$. (96 unités)

Que la différence des nombres soit $\overline{\text{S}} \overline{\beta}$ ($2x$). Dès lors, puisque la somme des nombres est $\overline{\text{K}}$ (20) si nous la divisons en deux parties égales, chacune des parties sera la moitié de la somme, ou $\overline{\text{L}}$ (10). Donc, si nous ajoutons à l'une des parties, et si nous retranchons de l'autre partie, la moitié de la différence des nombres, c'est-à-dire $\overline{\text{S}} \overline{\alpha}$ ($1x$), il s'établit de nouveau que la somme des nombres est $\overline{\text{K}}$ (20), et que leur différence est $\overline{\text{S}} \overline{\beta}$ ($2x$). En conséquence, posons que le plus grand nombre est $\overline{\text{S}} \overline{\alpha} \overline{\text{L}}$ ($1x + 10$) donc le plus petit sera $\overline{\text{L}} \overline{\text{S}} \overline{\alpha}$ ($10 - 1x$), et il s'établit que la somme des nombres est $\overline{\text{K}}$ (20), et que leur différence est $\overline{\text{S}} \overline{\beta}$ ($2x$). Il faut aussi que le produit des nombres fasse $\overline{\text{Q}\overline{5}}$ (96). Or le produit est $\overline{\text{P}} \overline{\text{L}} \overline{\Delta} \overline{\gamma} \overline{\alpha}$ ($100 - 1x^2$), ce que nous égalons à $\overline{\text{Q}\overline{5}}$ (96), et $\overline{\text{S}}$ devient $\overline{\text{L}} \overline{\beta}$ (2).

En conséquence, le plus grand nombre sera $\overline{\text{L}} \overline{\beta}$ (12), le plus petit sera $\overline{\text{L}} \overline{\eta}$ (8) et ces nombres satisfont à la proposition.

Les biobibliographes arabes, tel Ibn al-Nadim au 10^e siècle, disent de Diophante que c'est "un grec alexandrin qui a écrit un livre sur l'Art de l'Algèbre". La traduction en arabe des *Arithmétiques* de Diophante, au 9^e siècle, par Ibn Luqa a d'ailleurs pour titre *l'Art de l'Algèbre*. Quand à la fin du 16^e siècle l'Europe redécouvre l'œuvre de Diophante, les grands algébristes Bombelli (Italie), Stevin (Flandres), Viète (France), l'intègrent dans leurs traités. Ainsi, si l'œuvre de Diophante marque sans conteste l'avènement de la méthode algébrique en mathématique, son traité n'est pas, comme celui d'Al Khwarizmi, un traité des équations, mais un recueil de problèmes résolus avec cette méthode "pas encore connue". En effet, Al Khwarizmi partage son traité en deux parties. Dans la première il explique ce qu'est le calcul d'al-jabr et al-muqabala, et qu'il porte sur trois classes de nombres : les carrés, les racines et les nombres simples. Il envisage toutes les combinaisons possibles pour les équaler, et est donc amené à considérer six types d'équations :

Les cas simples	1) Des carrés égaux à des racines	$(ax^2 = bx)$
	2) Des carrés égaux à des nombres	$(ax^2 = c)$
	3) Des racines égales à des nombres	$(bx = c)$
Les cas combinés	4) Des carrés et des racines égaux à des nombres	$(x^2 + bx = c)$
	5) Des carrés et des nombres égaux à des racines	$(x^2 + c = bx)$
	6) Des racines et des nombres égaux à des carrés	$(bx + c = x^2)$

A chaque type est consacré un chapitre expliquant sa résolution.

La seconde partie du traité est consacrée à la résolution de problèmes, et montre comment, par al-jabr et al-muqabala, on les ramène à l'une des six formes canoniques. On voit ainsi en quoi le traité d'Al Khwarizmi inaugure un nouveau point de vue et fonde un nouveau domaine des mathématiques dans lequel vont s'engager les mathématiciens arabes, puis à leur contact les italiens. Cela apparaît

clairement dans les réflexions suivantes d'Al Khayyam, tirées de son traité d'Algèbre de 1074 : "L'algèbre est un art scientifique...ce qu'on cherche dans cet art, ce sont les relations qui joignent les données des problèmes à l'inconnue, qui forme l'objet de l'algèbre... Ce qu'on trouve dans les ouvrages des algébristes, relativement à ces quatre quantités géométriques, entre lesquelles se forment les équations, à savoir : nombres absolus, côtés, carrés et cubes, ce sont trois équations renfermant le nombre, des carrés et des côtés. Nous allons, au contraire, proposer des méthodes au moyen desquelles on pourra déterminer l'inconnue dans l'équation contenant les quatre degrés... Lorsque l'objet du problème est le nombre absolu, ni moi, ni aucun des savants qui se sont occupés d'algèbre, n'avons réussi à trouver la démonstration de ces équations (et peut-être un autre qui nous succèdera comblera-t-il cette lacune), que lorsqu'elles renferment seulement les trois premiers degrés, à savoir : le nombre, la chose et le carré..."

Cette résolution algébrique des équations du troisième degré, qu'Al Khayyam appelait de ses vœux, ce sont les algébristes italiens du 16^e siècle, Del Ferro, Tartaglia, Cardan, Bombelli, qui vont la réussir, avec en prime celle des équations du quatrième degré. Cette avancée significative est accompagnée d'un progrès du symbolisme, et de calculs sur des nombres nouveaux : négatifs et imaginaires. Ces nombres feront d'ailleurs par la suite partie intégrante des traités d'algèbre. Les relatifs seront tellement perçus comme ayant partie liée avec l'algèbre qu'il seront dénommés dans les manuels français jusqu'en 1970 nombres algébriques.

Quant aux symboles ce sont surtout des signes d'abréviation. Voici un extrait du calcul sur les binômes figurant dans la sixième partie du *Traité général du nombre et de la mesure* de Tartaglia de 1560.

Del summar de binomi, & residui de dignità Algebraice.



U non te voglio star a narrare particolarmente in parole il summar de binomi & residui de dignità, perche ve andaria da scriuere assai, ma te ponerò solamente vari, & diuersi summari in figura, li quali hauendo ben in memoria le operationi delli duoi termini, piu, e men, come di sopra è stato detto facilmente da te le intenderai.

a summar 13 piu 7 co.
con 12 piu 3 co.

fara 25 piu 10

a summar 10 men 8 co.
con 13 men 5 co.

fara 23 men 13 co.

a summar 5 ce. piu 3
con 2 ce. piu 2

fara 7 ce. piu 5

a summar 12 piu 13 ce.
con 8 men 5 ce.

fara 20 piu 7 ce.

a summar 9 cu. piu 8 co.
con 5 cu. piu 6 co.

fara 12 cu. piu 14 co.

a summar 7 cu. men 6 co.
con 5 cu. piu 4 co.

fara 12 cu. men 3 co.

co est l'abréviation de cosa, ce de censo, cu de cubo.

Le dernier des 6 calculs ci-dessus correspond à $(7x^3 - 6x) + (5x^3 + 4x) = 12x^3 - 2x$. Il est à noter que Nuñez, professeur à Coimbra, utilise, dans son *Libro de algebra* de 1567, les notations de Tartaglia. Mais l'essentiel des explications et des calculs

DE L'ALGEBRE. III

p. 45, seront egales a 124. Voçla noz troçs Equacions principales : lequels il faut mêlir de tele sorte , que nous trouuons les differances des nombres Absoluz , repondantes aus nombres Cosiques.

Disposons donq noz troçs Equacions an cete sorte.

I. 2x p.11 p.16, egales a 64.

II. 1x p.31 p.18, egales a 84.

III. 1x p.11 p.45, egales a 124. Ajoutons la se-

passé par le langage courant. On voit néanmoins apparaître des lettres pour désigner les inconnues comme chez l'allemand Stifel ou le français Peletier. Voici comment ce dernier note dans son *Algèbre* de 1544 le système :

- (1) $2x + y + z = 64$
- (2) $x + 3y + z = 84$
- (3) $x + y + 4z = 124$.

C'est à la fin de ce 16^e siècle, où foisonnent les notations nouvelles et les traités d'algèbre, où l'on redécouvre les auteurs grecs, – en particulier Diophante, pour le domaine qui nous intéresse, dont les *Arithmétiques* sont traduites en latin par Xylander en 1575 –, que va s'opérer un progrès conceptuel décisif.

Le langage universel

L'algèbre littérale de Viète

En quoi consiste ce progrès ? Il s'agit de la création d'un calcul portant uniquement sur des lettres que Viète expose dans un court traité, véritable manifeste édité à Tours en 1591 sous le titre : *Introduction à l'Art analytique ou Algèbre nouvelle*. Il a conscience d'opérer une rupture et d'ouvrir la voie à un progrès important.

"La forme sous laquelle on doit aborder la recherche de l'équation (Zétèse) exige les ressources d'un art spécial, qui exerce sa logique non sur des nombres, suivant l'erreur des analystes anciens, mais au moyen d'une Logistique nouvelle, beaucoup plus heureuse que la Logistique numérale..." (Chapitre I)

"Logistique numérale est celle qui est exposée par des nombres. Logistique spécieuse est celle qui est exposée par des signes ou des figures, par exemple, par des lettres de l'alphabet..." (Chapitre IV)

"Diophante a employé la zététique plus ingénieusement que tout autre auteur dans les livres qu'il a écrits sur l'Arithmétique. Cependant il l'a représentée établie par des nombres et non par des espèces, dont cependant il a fait usage, ce qui doit faire admirer davantage sa subtilité et son talent, car les choses qui paraissent plus difficiles et abstruses à celui qui emploie la Logistique numérale, sont familières et immédiatement claires à celui qui emploie l'arithmétique spécieuse." (Chapitre V)

Comme nous l'avons vu, avant lui certains algébristes utilisent des caractères pour désigner l'inconnue et ses puissances et parfois même des lettres. Mais les règles et

les méthodes sont exemplifiées avec des coefficients numériques. La grande idée de Viète est d'avoir généralisé l'utilisation de lettres aussi bien pour désigner les quantités inconnues que les quantités connues.

"Afin que cette méthode (la mise en équation) soit aidée par quelque artifice, on distinguera les grandeurs données des grandeurs inconnues et cherchées en les représentant par un symbole constant, invariable et bien clair, par exemple, en désignant les grandeurs cherchées par la lettre A ou par toute autre voyelle E, I, O, U, Y, et les grandeurs données par les lettres B, C, D ou par toute autre consonne." (Chapitre V)

Viète se trouve donc en possession d'un calcul littéral, sa logistique spécieuse. Dans quel but ? La dernière phrase de son court traité nous donne la clé : "NULLUM NON PROBLEMA SOLVERE", résoudre tout problème. En effet un certain nombre de problèmes des géomètres grecs étaient toujours non résolus. Parmi les plus célèbres : la duplication du cube, la quadrature du cercle, la trisection de l'angle, la construction de l'heptagone régulier. Pour envisager leur résolution il fallait donc essayer de trouver de nouveaux outils. Viète va s'attaquer victorieusement à certains de ces problèmes grâce à sa logistique spécieuse : l'analyste "résout artificieusement les problèmes les plus fameux appelés jusqu'à présent irrationnels, tels que le problème mésographique, celui de la section d'un angle en trois parties égales, l'invention du côté de l'Heptagone et tous les autres qui tombent dans ces formules d'équations..." Une fois le problème traduit dans la langue de la nouvelle algèbre, la possibilité de faire des calculs sur les expressions littérales obtenues permet alors de trouver des relations entre grandeurs, jusque là inconnues. C'est ainsi, par exemple que Viète, établit de nombreuses formules trigonométriques en particulier pour l'addition et la multiplication des angles.

Alors que les équations envisagées par les mathématiciens étaient au maximum de degré 4, le partage d'un angle en n parties égales conduit à des équations de degré n , n pouvant être très grand. C'est ainsi qu'en 1594 Viète relève un défi mathématique : résoudre une équation de degré 45 ! C'est le fameux problème d'Adrien Romain dont il donne les 23 solutions positives en quelques heures. Si Viète peut résoudre aussi facilement le problème, c'est qu'il lit, derrière l'équation particulière du 45° degré qui lui est proposée, un problème général de géométrie : Comment partager un angle en 45 parties égales ? Ce problème est du même type que le fameux problème de la trisection de l'angle : Comment partager, à la règle et au compas, un angle en trois parties égales ? Viète avait mis à l'épreuve son algèbre nouvelle sur ce problème de géométrie, comme il l'avait d'ailleurs fait sur les problèmes arithmétiques de Diophante. Son «Art» étant général, il avait abordé le partage de l'angle pour tous les cas possibles dans son ouvrage *La section des angles* qui contient la liste des équations correspondant à chacun des cas, ainsi que les formules trigonométriques de base, énoncées pour la première fois sous forme générale. Voici, en exemple et en abrégé, son théorème 2 :

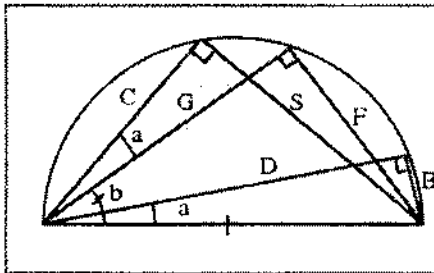

Avec ses notations: (in signifie multiplié par)

S est F in D + B in G

C est G in D - F in B

Avec nos notations :

$\sin(a+b) = \sin b \cos a + \sin a \cos b$

$\cos(a+b) = \cos b \cos a - \sin b \sin a.$

Les clés de sa réussite, il les doit à son algèbre littérale qui lui permet :

- d'acquérir une puissance de calcul encore inégalée : des substitutions et des développements, tels que ceux utilisés pour l'identification de l'équation d'Adrien Romain, étaient impensables auparavant. Cette utilisation de l'algèbre littérale pour transformer et résoudre des équations va lui permettre de faire avancer leur théorie. Il en fait un traité intitulé *Revue et transformation des équations* qui se termine par un théorème donnant les relations entre les coefficients et les racines d'une équation, théorème qui aura une grande importance par la suite. Même sa résolution numérique des équations, dont il a fait également un traité, utilise des résultats littéraux établis dans ses *Premières notes*, traité qui fait suite à *l'Introduction à l'art analytique* ;

- de traduire sous forme d'équations et de formules des problèmes généraux de géométrie et d'arithmétique. Cette utilisation de la méthode analytique et de l'algèbre littérale pour modéliser des situations, Descartes va la reprendre et la développer.

Il est clair que pour Viète l'algèbre est un outil au service d'une méthode de résolution de problèmes : l'analyse. Mais leurs rôles étant tellement imbriqués, une confusion va s'installer entre algèbre et analyse, qui est déjà présente dans le titre même que Viète a choisi pour son manifeste : *Introduction à l'Art analytique ou Algèbre nouvelle*.

L'outil de la méthode cartésienne

"Par la méthode dont je me sers, tout ce qui tombe sous la considération des Géomètres, se réduit à un même genre de Problèmes, qui est de chercher la valeur des racines de quelque Equation.". Par cette phrase de son traité de 1637, *La Géométrie*, Descartes se fait l'initiateur d'une méthode à laquelle son nom va rester attaché : l'algébrisation de la géométrie. Il faut noter que Descartes ne limite pas sa méthode à la géométrie, et que s'il l'utilise à l'occasion pour résoudre des problèmes arithmétiques, dès le début de ses recherches, il l'a voulue universelle pour "résoudre généralement toutes les questions qui peuvent se présenter en n'importe quel genre de quantité aussi bien continue que discrète."

Les caractéristiques de la méthode cartésienne sont bien connues. Voici comment Descartes lui-même la décrit dans sa *Géométrie* : "Ainsi voulant résoudre quelque problème, on doit le considérer comme déjà fait, et donner des noms à toutes les

lignes, qui semblent nécessaires pour le construire, aussi bien à celle qui sont inconnues, qu'aux autres. Puis sans considérer aucune différence entre ces lignes connues, et inconnues, on doit parcourir la difficulté, selon l'ordre qui montre le plus naturellement de tous en quelle sorte elles dépendent mutuellement les unes des autres, jusqu'à ce qu'on ait trouvé moyen d'exprimer une même quantité en deux façons : ce qui se nomme une Equation."

Si la première étape de la méthode relève de ce que, depuis les Grecs, on appelle l'analyse, c'est aussi un des principes de l'algèbre.

Les deuxième et troisième étapes, inaugurées par Viète, prennent chez Descartes une extension capitale ; en effet la mise en lettres permet la modélisation de problèmes de toutes sortes : constructions géométriques, construction des tangentes, ensembles de points, problèmes d'optique.... Ces problèmes complexes comportant plusieurs inconnues et de nombreux paramètres confrontent immédiatement son utilisateur à une quantité de calculs sans commune mesure avec celle gérée par les algébristes du siècle précédent. Pour en avoir une idée, examinons le problème que Descartes prend pour exemple dans sa *Géométrie*.

	<p><i>Enoncé :</i> Trouver C tel que $\frac{CB \times CF}{CD \times CH} = \text{constante}$</p> <p><i>Données :</i></p> <ul style="list-style-type: none"> - les droites (AB), (DA), (FE), (GT); - les angles de projection de C sur ces droites, soit : $\widehat{CBA}, \widehat{CDA}, \widehat{CFE}, \widehat{CHG}$.
--	--

Mise en équation :

2 inconnues : $AB=x, CB=y$

9 paramètres : $AE=k, AG=l, \frac{AB}{BR} = \frac{z}{b}, \frac{CR}{CD} = \frac{z}{c}, \frac{BE}{BS} = \frac{z}{d}, \frac{CS}{CF} = \frac{z}{e}, \frac{BG}{BT} = \frac{z}{f}, \frac{TC}{CH} = \frac{z}{g}$

4 distances : $CB=y, CF = \frac{ezy + dek + dex}{zz}, CD = \frac{czy + bcx}{zz}, CH = \frac{gzy + fgl - fgx}{zz}$

L'équation : $yy = \frac{(-dekzz + cfglz)y + (-dezzx - cfgzx + bczx)y + (bcfglx - bcfzxx)}{ezzz - czzz}$

Equation qu'il écrit, après de nombreux changements de paramètres :

$$y = m - \frac{n}{z}x + \sqrt{mm + ox - \frac{p}{m}xx}$$

Il étudie alors cette équation générale sous cette forme pour identifier la courbe, lieu des points C. Ce qui lui permet de prouver que cette équation est l'équation générale d'une conique. On assiste là à la naissance d'un nouveau champ de recherches : être capable de connaître un ensemble de points à partir de son équation.

Dans le cas présent, grâce à l'étude des diverses expressions littérales intervenant dans la mise en équation du problème, Descartes peut dire des choses sur le lieu du point C quand, au lieu de la donnée de 4 droites, on en donne 5, 6, 7...ou quand certaines droites sont parallèles. C'est là un des intérêts du calcul littéral. En effet chaque distance s'exprime linéairement en fonction de x et y, et on peut donc connaître le degré de l'équation en x et y. Reste, à partir de ce degré, à connaître la nature de la courbe. C'est ce travail qu'inaugure Descartes dans sa *Géométrie*.

Cet exemple permet de mesurer l'avancée et les transformations opérées par Descartes dans le champ de l'algèbre. Tout d'abord le domaine des équations s'élargit et s'enrichit de nouvelles questions et de nouvelles méthodes : étude des équations à deux variables, nombre et signe des racines des équations, méthode des coefficients indéterminés.... Mais surtout l'algébrisation des problèmes va donner une importance croissante au calcul littéral, et faire de cette méthode et de ce calcul l'essence de l'algèbre, comme en témoigne l'article *Algèbre* de l'*Encyclopédie Méthodique* de Diderot et D'Alembert 150 ans plus tard : "Science du calcul des grandeurs considérées généralement... Quelques Auteurs définissent l'Algèbre, l'art de résoudre les problèmes mathématiques ; mais c'est là l'idée de l'Analyse ou de l'art analytique plutôt que de l'Algèbre... L'Algèbre a proprement deux parties : 1° la méthode de calculer les grandeurs, en les représentant par les lettres de l'alphabet ; 2° la manière de se servir de ce calcul pour la solution des problèmes..."

On voit la mutation qui s'opère : l'algèbre devient un langage avec ses règles, langage qui permet de résoudre les problèmes par le calcul.

Ainsi Condillac, en 1798, dans sa *Langue des calculs*, peut-il dire : "Les mathématiques sont une science bien traitée dont la langue est l'algèbre".

Le domaine des structures

Très vite les mathématiciens se saisissent de l'outil et de la méthode cartésienne pour traiter tous les problèmes au moyen du langage et du calcul algébriques, et vont ainsi faire de nombreuses découvertes. En l'espace de peu de temps, le langage algébrique est omniprésent.

En voici un exemple, extrait du traité du Marquis De l'Hospital : *Analyse des infiniments petits pour l'intelligence des lignes courbes* (1696, p. 13), dans lequel il s'agit de tracer la tangente à une ellipse.

12. SOIT une ligne courbe AMB telle que $AP \times PB$
 $(x \times a - x) \cdot PM^2 (yy) :: AB (a) \cdot AD (b)$. Donc $\frac{ayy}{b} = ax$
 $- xx$, & en prenant les différences, $\frac{2ay dy}{b} = adx - 2x dx$,
 d'où l'on tire $PT \left(\frac{dy}{dx} \right) = \frac{2ayy}{ab - 2bx} = \frac{2ax - 2xx}{a - 2x}$, en met-
 tant pour $\frac{ayy}{b}$ la valeur $ax - xx$; & $PT = AP$ ou AT
 $= \frac{ax}{a - 2x}$.

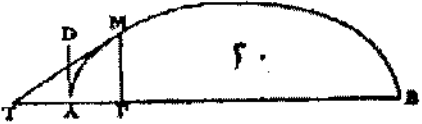

Le texte montre bien la modélisation du problème avec le langage algébrique (chaque longueur est désignée par une lettre, ou exprimée en fonction de celles déjà utilisées) et l'utilisation du calcul algébrique pour trouver la distance AT qui permettra la construction de la tangente. Mais pointons deux faits importants qui apparaissent ici.

D'abord, les lettres qui interviennent dans le calcul représentent des grandeurs géométriques (x, y, a, b), mais aussi des grandeurs infinitésimales (dx, dy): le calcul algébrique est donc susceptible de traiter toutes sortes de grandeurs. Cette idée va faire son chemin. Après le calcul sur les différences de Leibniz, on voit apparaître au 19^e siècle toutes sortes de calculs portant sur les objets les plus divers: les congruences de Gauss (1801), le calcul barycentrique de Möbius (1827), les couples (1837) et les quaternions (1853) de Hamilton, le calcul vectoriel de Grassmann (1844), le calcul des substitutions de Cauchy (1846), les lois de la pensée de Boole (1854), les matrices de Cayley (1858)...

Le deuxième fait important est que les lettres x, y ne désignent plus des quantités inconnues, mais des quantités variables, donc susceptibles de prendre une infinité de valeurs. Or en substituant aux lettres des valeurs familières (nombres positifs entiers, fractionnaires ou irrationnels), les expressions algébriques restituent des valeurs étranges: négatives, imaginaires. Ce qui amène à penser que les lettres du calcul algébrique peuvent représenter toutes sortes de nombres. Ainsi pour Euler, dans son *Introduction à l'Analyse infinitésimale* de 1748, une quantité variable "comprend tous les nombres tant positifs que négatifs, les nombres entiers et fractionnaires, ceux qui sont rationnels, irrationnels et transcendants; on ne doit pas même en exclure zéro, ni les nombres imaginaires. On peut lui substituer tous les nombres imaginables". D'autant que les combinaisons entre quantités variables et constantes s'étendent sans cesse au delà des opérations classiques de l'algèbre: addition, soustraction, multiplication, division, puissances et extractions des racines. Il faut y ajouter, aux dires mêmes d'Euler, "les transcendentes: comme les

exponentielles, les logarithmiques, et d'autres sans nombre, que le Calcul Intégral fait connaître". Là aussi, après les négatifs et les complexes, on va voir apparaître au 19^e siècle des calculs sur toutes sortes de nombres : les entiers de Gauss (1801), les nombres idéaux de Kummer (1844), les nombres algébriques de Dedekind (1871) ...

Les nombreux résultats obtenus par la manipulation de plus en plus formelle du calcul littéral, et par la substitution de toutes sortes de nombres dans les expressions symboliques obtenues, amènent les algébristes anglais du 19^e siècle à envisager une algèbre symbolique, où les lettres peuvent représenter des objets quelconques ; et sur lesquelles on peut faire toutes les opérations possibles a priori. Les mathématiciens vont alors concentrer leur attention non plus sur les objets, mais sur les opérations. Ainsi Boole écrit-il en 1847 : "La mathématique traite des opérations considérées en elles mêmes indépendamment des matières diverses auxquelles elles peuvent être appliquées", et De Morgan deux ans plus tard : "...aucun mot ou signe de l'arithmétique ou de l'algèbre n'a une parcelle de signification à travers tout ce chapitre dont l'objet est précisément les symboles et leurs lois de combinaison, donnant une algèbre symbolique qui peut désormais devenir la grammaire d'une centaine d'algèbres distinctes".

C'est cette étude d'ensembles abstraits munis d'une ou plusieurs opérations qui va désormais porter le nom d'algèbre, dont les objets vont s'appeler groupes, anneaux, corps, matrices, espaces vectoriels... Nous assistons à la deuxième métamorphose de l'algèbre et à la naissance de l'algèbre moderne, celle de l'*Algebra* de Lang : un domaine où l'on étudie des structures, nouveau langage des mathématiques qui unifie des domaines très divers et permet leur modélisation.

كل زاوية من النصفان اثنان ونصف في اثنين ونصف فصار الذي يحتاج إليه من الزيادة حتى يتربع السطح اثنان ونصف في مثله أربع مرات ويميل ذلك جميعه خمسة وعشرون . وقد علمنا أن السطح الأول الذي هو سطح المال والأربعة السطوح التي حوله وهي عشرة أجزاؤه هي تسعة وثلاثون من العدد. فإذا زدنا عليها الخمسة والعشرين التي هي المربعات الأربع التي هي على زواياها سطح آب ثم تربع السطح الأعظم وهو سطح وهّ وقد علمنا أن ذلك كله أربعة وستون وأحد أضلاعه جذره هو ثمانية فإذا نقصنا من الثمانية مثل ربع المشرة مرتين من طرفي ضلع السطح الأعظم الذي هو سطح وهّ وهو خمسة بين من مثله ثلاثة وهو جذر ذلك المال . وإنما نصفنا المشرة الأجزاء وضربناها في مثله وزدناها على العدد الذي هو تسعة وثلاثون ليم لنا بناء السطح الأعظم بما نقص من زواياه الأربع لأن كل عدد يضرب بربعه في مثله ثم في أربعة يكون مثل ضرب نصفه في مثله فاستغنيا بضرب نصف الأجزاء في مثله عن الربع في مثله ثم في أربعة وهذه صورته .

مربع مجهول الأضلاع وهو المال الذي تريد أن تعرفه وتعرف جذره وهو سطح آب وكل ضلع من أضلاعه فهو جذره وكل ضلع من أضلاعه إذا ضربته في عدد من الأعداد فأبليت الأعداد فهي أعداد جذور . كل جذر مثل جذر ذلك السطح فلما قيل إن مع المال عشرة أجزاؤه اخذنا ربع المشرة وهو اثنان ونصف وصيرنا كل ربع منها مع ضلع من أضلاع السطح فصار مع السطح الأول الذي هو سطح آب أربعة سطوح متساوية طول كل سطح منها هو مثل جذر سطح آب وعرضه اثنان ونصف وهي سطوح ج ط ك ح فحدث سطح متساوي الأضلاع مجهول أيضا فالص ل ن زواياه الأربع في

سنة ربيع	ح	سنة ربيع
هـ	المال	ك
سنة ربيع	ط	سنة ربيع

Al Khwarizmi. *Kitab al-Jabr wul-Muqabala*. Résolution de l'équation : $x^2 + 10x = 39$

THE CALCULUS, OUT OF THE BLUE?

Jan van Maanen, University of Groningen

1 Motivation and demarcation

In the beginning there was no calculus. Yet, rather early, mathematicians and especially Archimedes used infinitesimal techniques for finding tangents and areas. Mid-16th century Archimedes-editions introduced these techniques in Europe. This was one of many reasons for the vivid interest in tangents and areas during the 17th century. The quantitative description of motion also stimulated this interest, as did optical studies. The passage of light through a lens involved the normal to the surface of the lens. In the study of a particle which moves along a path, the tangent to the path appears. Methods for normals and tangents gave clues to treat maximising and minimising problems in physics, astronomy and mathematics, and anywhere problems about lengths of curves, areas between curves, volumes and centres of gravity of bodies arose. Starting with Kepler and Cavalieri mathematicians tried to find methods for analyzing these problems. Some solutions by Archimedes were known, but Archimedes' method of exhaustion aimed at proving results and did not indicate how he had found them, so there was a great need for a heuristic method.

Towards the end of the 17th century Newton and Leibniz created their heuristic methods of fluxions and differentials, in which the tangent problem and the quadrature problem were treated as related problems that could be solved by one operation (differentiation) or its inverse (integration). Only then the calculus was born.

Many developments followed before the calculus was well established, until in the 19th century the geometrical cornerstones were removed and the calculus was based on arithmetical principles. And in the 20th century the development went on, geometry became more important again and infinitesimals took on a new status in the non-standard analysis.

This essay focusses on the methods that preceded the calculus. For, one way of understanding what the calculus is for, is to study its precursors. The invention was a great leap forward. But the calculus did not appear out of the blue.

2 Pre-differentiation

2.1 Descartes on normals: first steps

The type of algebraic algorithms that, later in the century, inspired Newton and Leibniz depended on the work of Descartes and Fermat, who had made it possible to express curves algebraically and who used this to construct tangents and normals.

Descartes' contribution, published in his 1637 *Géométrie*, consists of a series of amazing steps.

[Step 1: characters] It all began with his wish to have an algorithm for solving geometrical construction problems. The Greeks had posed one such problem after another, but every new problem required a new insight, and in some cases these insights had been lacking ever since antiquity. Descartes proposed to use algebra. He suggested representing the line-segments involved in the construction with characters, known segments with characters from the beginning of the alphabet, the unknown(s) with characters from the end. That is where 'x' came into being. The geometrical properties of the figure then had to be translated into equations. Finally, the geometrical construction amounted to translating the solution of the equations into geometrical operations (just as $a + b$ is constructed from the segments a and b by attaching a and b to each other on the same line.

[Step 2: infinitely many solutions] Descartes next step was to discuss what should be done if there are more unknown lines than equations. These are his own words:

But if, after considering everything involved, so many [equations] cannot be found, it is evident that the question is not entirely determined. In such a case we may choose arbitrarily lines of known length for each unknown line to which there corresponds no equation. (1637, 313)

If, for example, the problem leads to one equation in two unknowns, one may choose y arbitrarily, and then x is determined by the equation, at least that is how Descartes operated himself.

[Step 3: a curve] Again a brand-new step followed, that is the idea that a pair of line-segments with respect to some coordinate axes determines a point, and that infinitely many pairs of line segments produce a curve.

Descartes could have stopped here, but he immediately went on with the construction of the normal to a curve through one of its points. The problem was stated in geometrical language, but Descartes realized that he could use algebra. If he wanted to know something about a curve, he could make use of its equation.

2.2 Descartes on normals: final step

In his final **[Step 4]** Descartes set out to construct the normal through the point $C(x_C, y_C)$ to a curve K , represented by the equation $f(x, y) = 0$, see fig. 1. For this purpose he considered the circles which pass through C and have centre $P(0, v)$ on the y -axis AG (note that Descartes did not yet have a standard orientation of the axes. Here the positive y -axis is oriented from A to G , and the positive x -axis from A upwards). Generally such a circle will, in the neighbourhood of C , intersect the curve CE at another point (as the circles with centres P_1 and P_2 do in fig 1), but if the radius is normal to K , the circle and the curve will have a double point of intersection (x_C, y_C) , and vice-versa. Now Descartes could translate the problem into algebraic language:

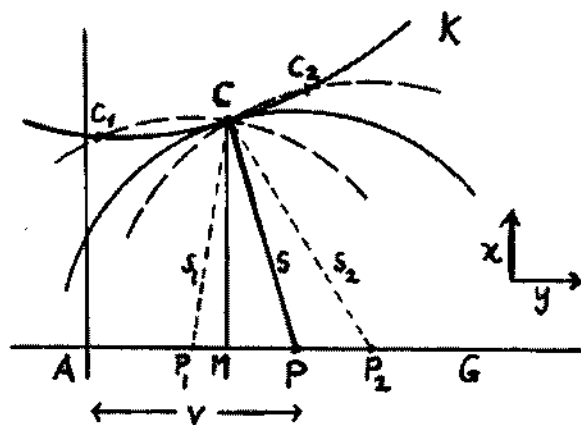

Figure 1: The normal to K through its point C

For which v is (x_C, y_C) a double root of the system

$$\begin{cases} f(x, y) = 0 \\ x^2 + (y - v)^2 = s^2 \end{cases} \quad (1)$$

where s is the radius, $s = \sqrt{x_C^2 + (y_C - v)^2}$.

Consequently, if y (or x) is eliminated from system (1), the resulting equation in x (or y), has a double-root x_C (or y_C , and from this information s and v can be determined as follows.

Suppose the polynomial equation, resulting from (1), is

$$x^n + a_{n-1}x^{n-1} + \dots + a_1x + a_0 = 0. \quad (2)$$

If (2) has a double-root $x = x_C$ (Descartes himself wrote $x = e$) it is of the form

$$(x - x_C)^2 p(x) = 0. \quad (3)$$

Here p is a polynomial of degree $n - 2$, in which the coefficient of x^{n-2} is 1 and the other $n - 2$ coefficients are still to be determined. Equating the coefficients a_0, a_1, \dots, a_{n-1} , in which s and v appear, with the corresponding coefficients of (3), which depend on the $n - 2$ undetermined coefficients of p , Descartes found a system of n equations in n variables, and since P depends only on v , it was sufficient for him to determine v from this system. His own example, the normal to an ellipse, will illustrate the procedure.

For the equation of the ellipse, Descartes used $x^2 = ry - \frac{r}{q}y^2$ which he had found by interpreting a theorem on the ellipse in Apollonius' *Conica* in his new algebraic language (r and q are the *latus rectum* and *latus transversum*, which in the classical theory of conic sections are used to determine the ellipse). For Descartes' own diagram see fig. 2. This time the positive y -axis is oriented from A towards the left, and the positive x -axis from A upwards.

In this case the elimination step was trivial, for

$$\begin{cases} x^2 = ry - \frac{r}{q}y^2 \\ x^2 + (y - v)^2 = s^2 \end{cases}$$

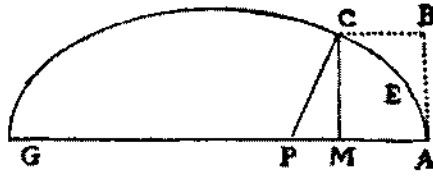

Figure 2: The case of the ellipse (*Géométrie*, p. 343)

allows direct elimination of x^2 , which led to

$$s^2 - v^2 + 2vy - y^2 = ry - \frac{r}{q}y^2,$$

(cf. system 1). Descartes reworked this to

$$y^2 + \frac{qr - 2qv}{q - r}y + \frac{qv^2 - qs^2}{q - r} = 0, \quad (4)$$

which is the 'resulting equation' (cf. equation 2). This equation has a double-root $y = y_C$, and therefore it should be compared with

$$(y - y_C)^2 = 0$$

(here $p(y) = 1$ since equation 4 is quadratic, cf. equation 3) and the pairs of coefficients to be equated are

$$\begin{cases} \frac{qr - 2qv}{q - r} = -2y_C \\ \frac{qv^2 - qs^2}{q - r} = y_C^2 \end{cases}$$

From the first pair v can already be found: $v = y_C - \frac{r}{q}y_C + \frac{1}{2}r$, and this completely determines P .

This finishes [Step 4], which was a series of steps in itself. Descartes had made enormous progress, too enormous even for many of his contemporaries. On the other hand more progress was needed. For, in the case of curves of higher order the normal method was unpleasant because of the increasing number of coefficients that had to be compared, not to mention transcendental curves, for which it did not work at all.

2.3 Fermat on extreme values

Simultaneously with Descartes Pierre de Fermat (1601–1665) developed his own method for representing curves algebraically, and for calculating tangents and extreme values. Fermat, who functioned in the Parliament of Toulouse, had little leisure

for doing mathematics. During his life his tracts circulated in manuscript form, and in this way his theory spread, but his work was published only after his death. By then the Cartesian approach was so well established that it could stand Fermat.

Like Descartes Fermat also directly used the algebraic representation of curves in order to study their properties. More than in normals he was interested in tangents, and —what will be discussed now— in extreme values.

Fermat's method for finding a maximum or minimum for a certain algebraic expression $I(x)$ is based on the observation that, if x_M is the value for which the extreme value is attained, $I(x)$ is constant in an infinitely small neighbourhood of x_M . Therefore, if e is very small, x_M satisfies the equation $I(x + e) = I(x)$.

From this equation common terms in x are removed, and then the resulting equation is divided by e . Any remaining terms in e are deleted, and from the remaining equation x_M is solved. Although the limit concept is absent, this makes a very modern impression, and it is difficult to resist the temptation to rephrase the algorithm as:

$$\text{solve } x_M \text{ from } \lim_{e \rightarrow 0} \frac{I(x + e) - I(x)}{e} = 0.$$

The following problem is an example by Fermat:

To divide the segment a in such a way that the product of the square of one of the segments with the other shall be a maximum.

Fermat's solution runs (in modern notation): let x be the part of the segment that is to be squared, then the product becomes $P(x) = x^2(a - x)$. So $P(x + e) = (x^2 + 2ex + e^2)(a - x - e)$ and $P(x + e) = P(x)$ results, when common terms have been removed, in the equation $(2ex + e^2)(a - x - e) - x^2e = 0$. This can be divided by e

$$(2x + e)(a - x - e) - x^2 = 0$$

after which terms, in which e still appears, are deleted: $2ax - 3x^2 = 0$. Here $x = 0$ leads obviously to the minimum $P(0) = 0$, en $x = \frac{2}{3}a$ yields the required maximum $P(\frac{2}{3}a) = \frac{4}{27}a^3$.

2.4 Further developments: Van Schooten and Hudde

Fermat could have set the standards for the future, but history chose Van Schooten as the next runner in the relay. Frans van Schooten (1615–1660) was an ardent propagator of Cartesian mathematics. Through his works the mathematical community (including all great names of the early calculus like Newton, Leibniz and the Bernoullis) learnt Descartes' 'geometry'.

Van Schooten translated the *Géométrie* into Latin (editions 1649 and, in two volumes, 1659–1661), he wrote a commentary on the text, he laid foundations, he linked the text to theory in other publications, he simplified arguments, and made corrections. Furthermore he systematized the contents, and he widened the scope of the text (i.e. he made generalizations, answered questions that Descartes had left open,

proposed new problems and extended the theory). Thanks to these activities Cartesian mathematics became accessible to a greater audience.

We shall conclude this part about pre-differentiation with a problem that was solved by Hudde, one of Van Schooten's students at Leiden, and included in the 1659-1661 *Geometria*. It concerned the tedious algebraic calculations involved in Descartes' double-root method. Hudde considerably simplified these calculations through, what was later called, 'Hudde's rule':

If an equation has two equal roots and it is multiplied by an arbitrary arithmetical progression (that is, the first term of the equation by the first term of the progression, the second term of the equation by the second term of the progression, and so on), then I say that the result will be an equation in which one of the said roots will be found again.

The rule, which for polynomials had the same effect as differentiation, became very popular. But for transcendental curves it did not work, and when the equation involved roots or when x appeared in a denominator, extensive reworking of the equation had to be done before it could be applied. To overcome these limitations with a universal method, that was the challenge Newton and Leibniz met with the calculus (from 1684 onwards, when Leibniz introduced differentiation) in combination with infinite series.

3 Pre-integration

Problems about length, area, volume and related subjects kept many 17th century mathematicians active. They came with new results and with new, heuristical methods. From their immense production a very sparse but coherent selection is presented here, the story about two men and one curve.

3.1 Huygens, Sluse and the cissoid

In the course of 1658 Sluse and Huygens began to investigate the cissoid. The cissoid is defined in a semi-circle with diameter AB (see fig. 3). Equal arcs AX and BC are measured. From X the perpendicular to AB is drawn, which meets AB in Q . The line AC is drawn which intersects QX (produced if necessary) at E . It is the locus of the point E as C moves along the semi-circle from A to B that is the cissoid. The curve rises to an asymptote, which is the tangent to the generating circle at B . Two properties of the cissoid will be needed for our later discussion.

[First property]

If AC produced meets the asymptote at F then because $AS = QB$, $AC = EF$ and $AE = CF$.

[Second property]

By similar triangles $EQ/AQ = CS/AS = XQ/BQ$. But \widehat{AXB} is a right angle so again by similarity $AQ/XQ = XQ/BQ$ so that

$$EQ/AQ = AQ/XQ = XQ/BQ$$

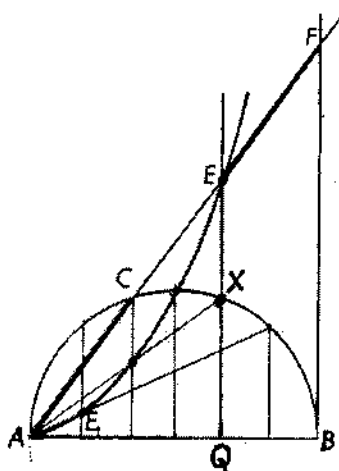

Figure 3: The cissoid of Diocles: the locus of E as C varies subject to arc $AX = \text{arc } BC$.

this proportionality being the second property.

Diocles introduced the cissoid in a book “On Burning Mirrors” in about 185 B.C. which was thought lost until its rediscovery by Toomer in 1976. The curve, however, was also described by Eutocius (born c. 450 A.D.) in his commentary on Archimedes, which was published in 1544 in the Basle edition of Archimedes’ *Opera*. This is how Sluse and Huygens had access to it.

Sluse and Huygens had two reasons for studying the cissoid. In the first place they aimed at deriving the quadrature of the circle from the quadrature of curves which are related to the circle. The cissoid is clearly one such curve. In the second place they were puzzled by Torricelli’s ‘improper integral’.

In about 1643 Torricelli had proved that the volume of the solid produced by revolving an orthogonal hyperbola around its asymptote is finite. Via Mersenne the news spread quickly. Sluse and Huygens were aware of the fact, which greatly surprised them, and they decided to try other curves of infinite length. The cissoid, which has an asymptote, was a candidate.

3.2 Sluse: the cissoid revolved

Sluse came up with the first result. In his letter to Huygens of 14th March 1658 he determined the volume of revolution of the cissoid about its asymptote, proving that the volume is finite. In the proof Sluse used Cavalieri’s method of indivisibles, in a way in which Cavalieri’s followers had interpreted it, which is: consider the solid as composed of elements of dimension 2, reorder these elements but keep their area and mutual distances fixed, this gives you a second solid which has the same volume as the first one. If you know the volume of the second solid, you have also determined the volume of the first. An analogous procedure was used for areas of plane figures.

For the cissoid Sluse used as indivisible elements cylindrical shells. In fig. 4 one such shell is depicted. It has height EQ and radius BQ , so its area is $2\pi \times BQ \times EQ$. From the second property of the cissoid $EQ/AQ = AQ/XQ = XQ/BQ$ Sluse

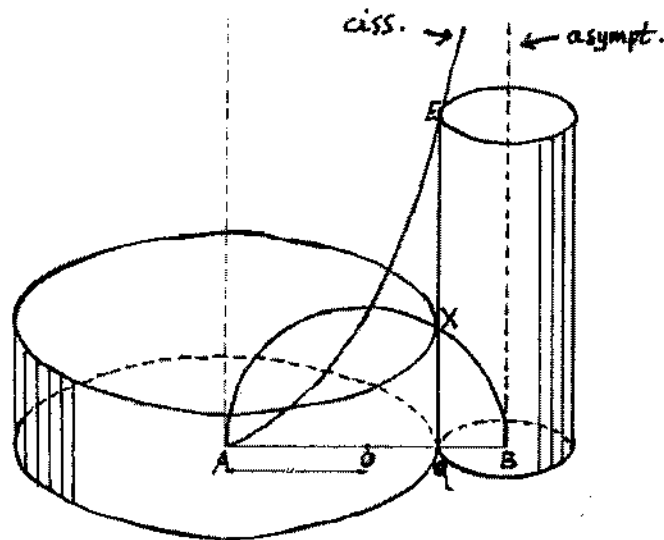

Figure 4: The cissoid revolved about its asymptote has the same volume as the semi-circle revolved about its tangent

knew that $2\pi \times BQ \times EQ = 2\pi \times AQ \times XQ$, and this implied that the shell has the same area as the cylinder which has height XQ and radius AQ . This last cylinder is produced if the semi-circle is revolved about its tangent through A. So,

area of cylinder on the left = area of cylinder on the right.

Therefore the volume of revolution of the cissoid about its asymptote is the same as the volume obtained by revolving the semi-circle about its tangent through A. The volume of this solid, which resembles an apple, had already been calculated by Kepler in his *New solid geometry of wine barrels* of 1615. The fruit metaphor is Kepler's.

Kepler's book contains a variety of very practical methods, sometimes directly modelled on a special situation, but sometimes also rather general. One of these will be illustrated here, the solid Sluse produced by revolving a semi-circle about its tangent will serve as an example.

Kepler made infinitely many equal slices by cutting the solid with planes through the axis of revolution. In this case (see fig. 5) the part of such a slice that touches the axis has thickness 0, the other side has an infinitesimal thickness, say t . The sum of all t is $2\pi \cdot 2a = 4\pi a$, if a is the radius of the circle. The slices can be piled up, each time with the thick side of the next one on the thin side of the former. This gives a cylinder with base πa^2 (the area of the revolved circle) and altitude $\frac{1}{2} \cdot 4\pi a$ (since two slices together contribute t). Hence the volume of the apple is $2\pi^2 a^3$.

This can also be considered as an instance of Pappus's theorem, which is also valid if a non-symmetrical plane figure is revolved about a line in its plane which does not intersect the figure:

the volume of the solid of revolution is equal to the area of the revolved figure times the

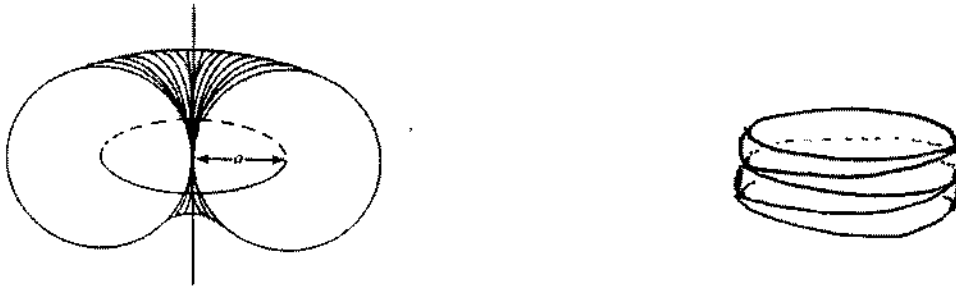

Figure 5: Kepler's 'apple'

length of the path travelled by its centre of gravity. (Guldin, c. 1640, also attributed to Pappus)

With this inspiration Huygens addressed the quadrature of the cissoid.

3.3 Huygens determines the quadrature of the cissoid

Some weeks after Sluse had determined the volume of revolution of the cissoid, Huygens found its quadrature:

The infinitely extended space between the cissoid ADE , the asymptote BF and the diameter AB of the generating semi-circle is three times the semi-circle. (letter to Sluse, 5 April 1658)

To prove this Huygens first drew an arbitrary line through A , which intersects the semi-circle in C , the cissoid in E and the asymptote in F (see fig. 6). This line cuts

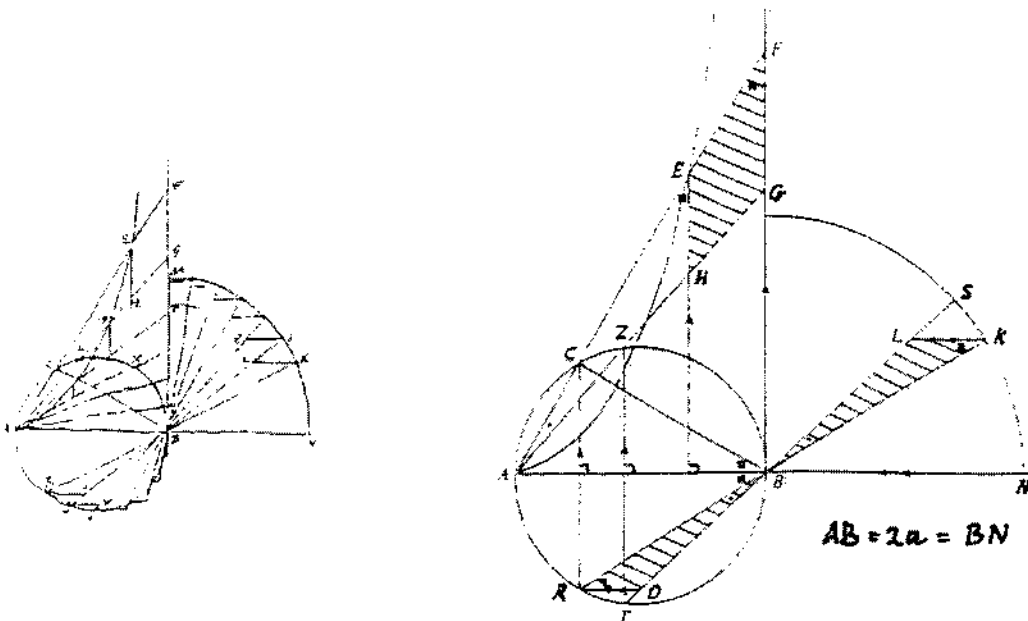

Figure 6: Huygens' diagram (28 May 1658 version, and redrawn)

off a finite part $ADEFBA$ from the infinitely extended space.

He also drew a quarter circle BMN , with radius $BN = BA$, made arc $BR =$ arc BC , and drew line RBK (K on the quarter circle). This line cuts from the lower semi-circle the segment BVR and from the quarter circle the sector BKM . Then, said Huygens:

$$ADEFBA = \text{segment } BVR + \text{sector } BKM. \quad (5)$$

This would indeed prove his claim, for if F on the asymptote tends to infinity, R on the lower semi-circle tends to A and K on the quarter circle tends to N (see fig. 7).

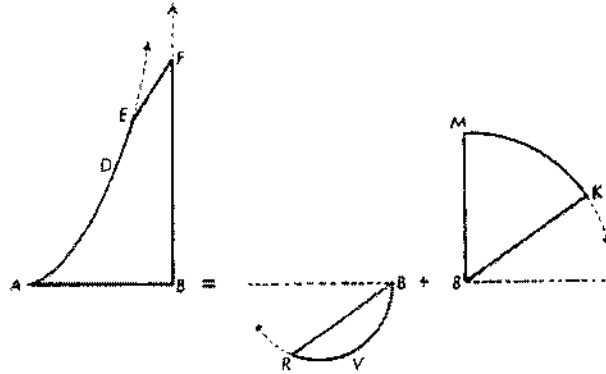

Figure 7: $ADEFBA = \text{segment } BVR + \text{sector } BKM$

So the infinitely long space bounded by cissoid, asymptote and AB is equal to the semi-circle BVA plus the quarter circle BMN . Together these make three times the generating semi-circle.

In this way Huygens has reduced the problem to the finite domain: to prove the equality (5). He wrote to Sluse:

In order to give the proof for the cut-off part $[ADEFBA]$ I divide arc CXB into equal little parts, and by drawing lines ADG etc. through the division points, I build within the space $ADEFB$ an inscribed figure, which is composed from the trapezia [with diagonals] EG, DP etc. Arc BR is divided in the same number of parts, and this gives, by drawing lines from the division points via B also a division of sector BKM in the same number of parts. Now let RO and TV , and also KL and SQ be parallel to AB . I shall now show that trapezium EG is equal to the opposite triangles ROB and BKL . Likewise, trapezium DP is equal to the triangles TVB and BSQ , etc. From this you will easily understand the rest.

With this limit argument Huygens had removed the curvilinear shapes from the scene, for he is now left with trapezia and triangles. "Understanding the rest" implied that Sluse had to realize that the inscribed figure within $ADEFBA$ (composed of the sequence of trapezia) equals the two inscribed figures of segment BVR and sector BKM taken together (composed of the two sequences of triangles), and that this equality will also hold in the case that arc BC is divided in infinitely many parts. For in that case (5) is proved.

The last step in the proof is to show that

$$\text{trapezium } EFGH = \text{triangle } ROB + \text{triangle } BKL.$$

The occurrence of similar triangles is essential in this proof. Because of common angles and parallel sides triangles AFG and AEH are similar. Because of opposite

angles and parallel sides BRO and BKL are similar. But also AFG and BRO are similar, for arc $CZ =$ arc RT (symmetry), and therefore $\angle CAZ = \angle RBT$; furthermore ACB is a right angle, and therefore $\angle AFB = \angle ABC = \angle ABR = \angle BRO$. In summary:

$$\triangle AFG \sim \triangle AEH \sim \triangle BRO \sim \triangle BKL.$$

Next see that

$$AF^2 = AB^2 + BF^2 = AB^2 + BC^2 + CF^2 = BK^2 + BR^2 + AE^2$$

(the last equality because $CF = AE$; this is the first property of the cissoid). The areas of similar figures are in proportion to the squares of their corresponding sides. So this last equality told Huygens that

$$\triangle AFG = \triangle BKL + \triangle BRO + \triangle AEH.$$

But $\triangle AEH$ is part of $\triangle AFG$, the other part being the trapezium $EFGH$, and therefore trapezium $EFGH = \triangle BKL + \triangle BRO$. And with this argument Huygens had completed his proof.

3.4 Sluse amazed

The correspondence continued for a while. Huygens realized that knowing both the area under the cissoid and the volume of its solid of revolution implied that he could also determine the centre of gravity. In order to do so he reflected the cissoid in AB , the diameter of the semi-circle (see fig. 8).

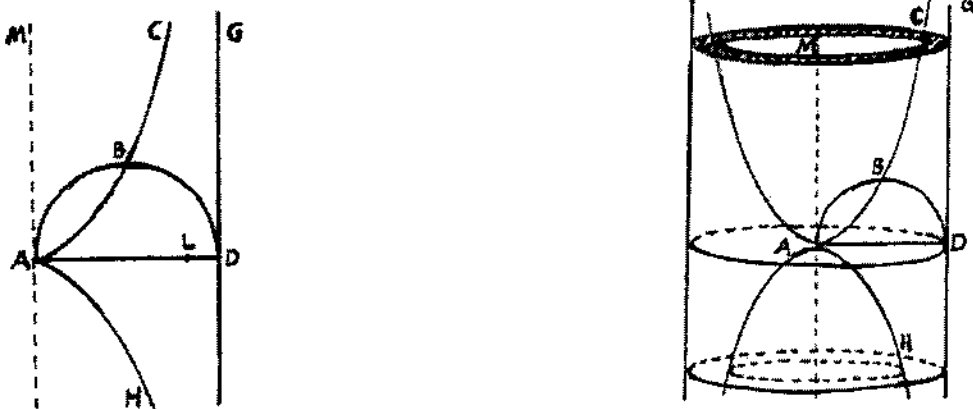

Figure 8: Sluse's infinite glass

If the space between the two branches of the cissoid and the asymptote is revolved about the asymptote this gives a whole apple, or $2\pi^2 a^3$, in which a is the radius of the generating semi-circle. Since the area of the revolved space is three generating circles, or $3\pi a^2$, the centre of gravity L on line AD can be calculated. During one revolution about the asymptote L travels along $2\pi \cdot DL$. With Guldin's theorem Huygens concluded that $2\pi^2 a^3 = 3\pi a^2 \cdot 2\pi DL$ or $DL = \frac{1}{3}a = \frac{1}{6} \cdot AD$. Then again it was Sluse's turn. He decided to revolve the space between cissoid

and asymptote also about the tangent in A . The solid so generated (an infinite 'egg-timer') has finite volume $3\pi a^2 \cdot 2\pi \cdot \frac{5}{3}a$ and therefore can be made from a finite amount of (say) glass. So, when empty it need not to be heavy. But the cavity within the solid has infinite volume (since it is the difference between the infinite cylinder described by the revolving asymptote and the finite mass of the egg-timer). Sluse apparently was happily amazed when he saw this, since, referring to this solid, he wrote to Huygens that he could design a glass "that has small weight, but that even the hardest drinker could not empty".

3.5 Exit Quadrature

Several techniques were used during the seventeenth century for finding quadratures, and many of these (e.g. by Fermat and Wallis, who used series, and by Roberval who was a master in indivisibles) had to remain undiscussed here.

In the end the geometrical methods of, for example, Huygens lost ground against the arithmetical methods. Geometrical methods could not be generally applied, whereas arithmetical methods were much more general and algorithmic. Already in 1671 Newton, who knew the quadrature of the cissoid via the work of Wallis (Huygens had sent it as a problem to Wallis, and Wallis solved it), used integration and solved the quadrature in a few lines.

In the beginning of the eighteenth century there was calculus. It had exploited the power of analytic geometry and, in one broad stroke, solved a variety of problems. It gave rise to applications and to the search for foundation of the theory. Another century, another essay.

References

A much longer version of this essay will appear in a forthcoming book about the *Geschichte der Analysis* (edited by Niels Jahnke). Several books discuss the invention of the calculus, e.g. [Baron 1969] and [Edwards 1979]. The 1637 edition of Descartes is easily available in [Descartes 1637/1925]. The Huygens-Sluse correspondence can be found in [Huygens 1889], the pre-integration story is based on [van Maanen 1991].

Baron M. 1969. *The origins of the infinitesimal calculus*. Oxford: Pergamon Press

Descartes R. 1637/1925. *The Geometry of René Descartes, with a facsimile of the first edition*. with English translation by D.E. Smith and M.L. Latham, Chicago: Open Court Publ.; reprint New York: Dover 1954

Edwards C.H. Jr. 1979. *The historical Development of the Calculus*. New York: Springer

Huygens C. 1889. *Œuvres Complètes de Christiaan Huygens*. vol. 2(1889) La Haye: Martinus Nyhoff (22 vols., 1888-1950)

Maanen J.A. van 1991. 'From quadrature to integration: thirteen years in the life of the cissoid', *Mathematical Gazette* 75 No. 471, pp. 1-15

TRIGONOMETRY

Victor J. Katz, University of the District of Columbia

The story of trigonometry is a long one, involving many civilizations over a long period of time. We can only here sketch some of the highlights. But I think these highlights provide a good bit of insight into the importance of trigonometry and how to use its history in teaching the subject.

Trigonometry in Greece and Egypt

The general presentation of trigonometry in school - beginning with the definition of the trigonometric ratios and continuing through the solution of right and other triangles and on to applications in indirect measurement - leads one to believe that trigonometry developed out of the desire to measure heights of buildings or distances across rivers. And although we also know that this can be done through similar triangles, it is usually simpler to do it using trigonometry. However true that may be, the historical record shows that the first users of trigonometry, the Greeks, did not develop trigonometry to perform such measurements. The reason for the development of trigonometry in Greece - and in fact for its use and continued improvement in many other cultures - had nothing to do with measurements on earth. It had everything to do with measurements in the heavens.

The study of the heavens and the desire to predict celestial phenomena were a significant part of the Greek scientific enterprise. But the heavens, of course, are spherical - just like the earth. And so the goal of the Greek development of trigonometry was to analyze arcs in the heavens - arcs of great circles - by studying the corresponding chords. So the subject began, not with the ratios of sides of a right triangle, but with the relationship between chords in circles and the arcs they cut off. Note that the chord of an arc - or the chord of an angle - is twice the sine of half the arc (assuming a radius of 1).

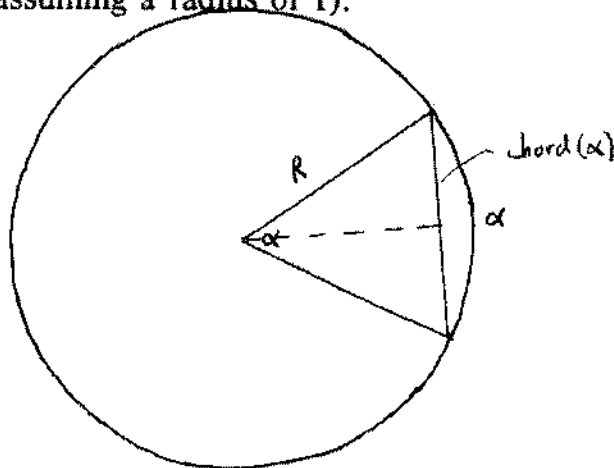

It was Hipparchus in the second century B.C.E. who first compiled a table relating the chord to its corresponding arc. Since he was interested in measuring the heavens, it was of no particular consequence what the actual length of the chords were (in feet or cubits or whatever). Thus the important point was to take a convenient length for the radius and then go from there. Hipparchus took 3438 for the radius = $60 \times 360 / 2\pi$ (i.e., the radius had the same measure as the circumference (minutes of arc)) - but, whose trigonometry work (the first part of the *Almagest*) was the most important in antiquity - decided that 60 would be easier to deal with because he was calculating in the Babylonian base 60 system. Ptolemy lived in the middle of the second century C.E. in Egypt - near Alexandria. But we know nothing about his life other than that.

If we read Ptolemy's trigonometry, we are impressed with his ability to calculate. He started by calculating the chords of arcs of 90, 60 and 36 degrees, using some basic geometry. For example, if we construct a 36-72-72 triangle with its vertex at the center of the circle (this construction is accomplished by Euclid in *Elements*, Book IV), the base MN is the chord of a 36 degree angle and can be easily calculated from the quadratic formula:

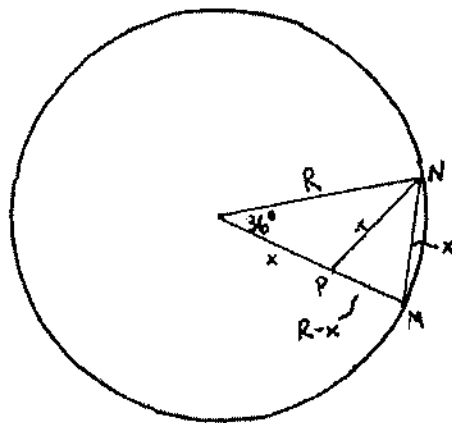

$$R : x = x : R - x$$

$$x^2 = R^2 - Rx$$

$$x = \text{chord}(36) = \sqrt{R^2 + \left(\frac{R}{2}\right)^2} - \frac{R}{2} = \sqrt{3600+900} - 30 = 37;4,55$$

Ptolemy then proved an equivalent to our half-angle formula as well as what is usually known as Ptolemy's theorem, that in any quadrilateral inscribed in a circle, the product of the diagonals equals the sum of the products of the opposite sides. This latter theorem enabled him to prove formulas for the chords of sums and difference of angles. These results, together with a very clever approximation technique, enabled him to provide us with a table of chords from 0 to 180 degrees in steps of 1/2 degree and with a method for interpolating for chords in between the calculated ones. Ptolemy was the first, I claim, to understand the notion of

"function of a real variable" - even though he didn't state that notion explicitly - as a relation between numbers representing measures of arcs and numbers representing measures of chords. His book, in fact, is filled with various functions dealing with astronomical issues, for all of which he gave detailed rules of calculation and, in fact, gave the results in tables. (I cannot but believe that he relied on numerous calculators to help him complete his tables.)

We will not consider Ptolemy's table construction here, but instead take a look at how he used his chords to solve triangles. We first consider a plane triangle. Suppose we know the hypotenuse of a right triangle as well as an angle γ and want to find the opposite side. Ptolemy's procedure is to circumscribe a circle about the triangle. Thus the central angle is 2γ and C is the chord of 2γ in a circle of radius $d/2$. Because the table is built on a radius of 60, we need to multiply the value $\text{chord}(2\gamma)$ found in the table by the ratio of $d/2$ to 60. In other words, the value C that we want is $(d/120) \text{chord}(2\gamma)$. Because 120 is twice the sexagesimal unit, we can rewrite this as $C = (d/2) \text{chord}(2\gamma)$. In other words, we need to find half the chord of twice the arc.

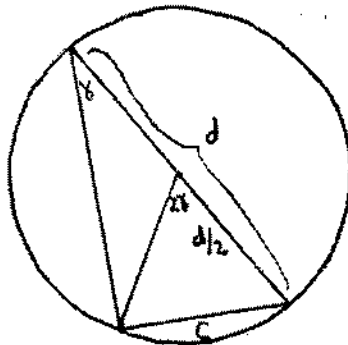

Having discussed other cases as well of solving plane triangles, including methods analogous to our laws of sines and cosines, Ptolemy moved on to discuss various methods of solving spherical triangles in the special case where one of the angles was a right angle. (Ptolemy's methods are adaptations of those originally developed by Menelaus, who lived perhaps 50 years earlier.) The basic principle was the Menelaus configuration and the relationship among the sides. In this configuration, two arcs AB , AC are cut by two other arcs BE , CD which intersect at F . With the arcs labeled as in the figure, the Menelaus result (written here in sines rather than chords) is:

$$\frac{\sin(n_2)}{\sin(n_1)} = \frac{\sin(s_2) \sin(m_2)}{\sin(s_1) \sin(m)}$$

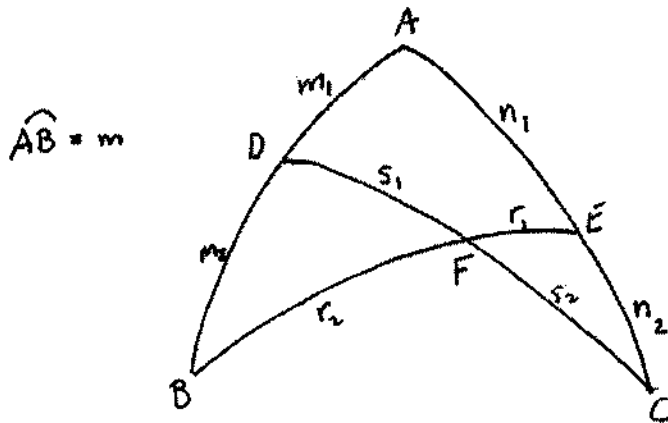

Ptolemy uses this and a similar method to solve spherical triangles by putting any right spherical triangle into one or two Menelaus configurations and applying the theorem as many times as necessary. Although to us his methods seem cumbersome, particularly because he always used chords (sines) and never used cosines or tangents explicitly, they were fine for Ptolemy and enabled him to solve all the astronomical problems he needed.

Trigonometry in India

We now trace some of the travels of trigonometry from Alexandria. Recall that in calculations involving triangles, Ptolemy did not use the chord of an angle, but in fact half the chord of double the angle. When Greek trigonometry reached India, the Indian scholars decided that it would be much simpler to tabulate the half-chords directly. Thus in India we see the beginning of the sine function. In fact, the *Surya-Siddhanta* of the fourth century records a sine table (table of half-chords) for angles ranging from $3\frac{3}{4}$ to 90 degrees in increments of $3\frac{3}{4}$ degrees, all based on a radius of 3438' (equal to 360×60 , the number of minutes in the circumference, divided by 2π). Thus the sines are given in the same units as the angles, namely minutes. By the sixth century, Indian scholars had also tabulated the cosine (sine of the complement), because that too was a common component in calculations. The *Surya-Siddhanta* itself showed how to calculate the tangent and secant of an angle (calling them the shadow and hypotenuse). That is, if one has a gnomon of length k casting a shadow from the sun which is at angle α from the zenith, the shadow length is equal to $k \tan \alpha$, while the hypotenuse is equal to $k \sec \alpha$.

It is interesting to note that although the Indians used the trigonometric functions to solve astronomical problems, they did not use trigonometry in connection with surveying. For example, to determine the height and distance of a pole with a light at the top, they used the following rule of Aryabhata (499):

The distance between the ends of the two shadows multiplied by the length of the first shadow and divided by the difference in length of the two shadows gives the koti; the koti multiplied by the length of the gnomon and divided by the length of the first shadow gives the height of the pole.

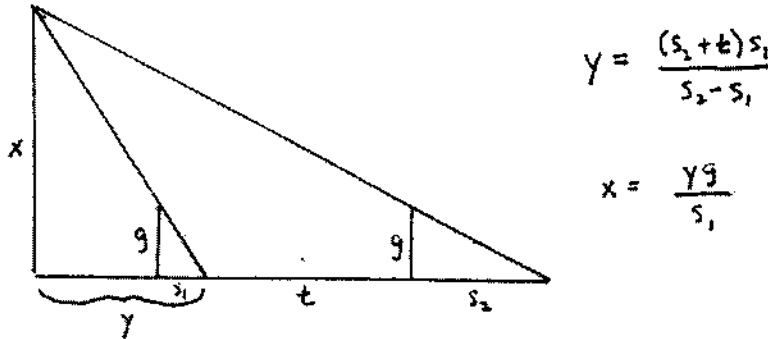

This method is quite similar to a basic Chinese procedure outlined in the *Sea Island Mathematical Manual* of the third century. In fact, this method, and analogous ones, were the favorite methods for doing indirect measurements in various societies around the world until the seventeenth century. Curiously, even though trigonometry was highly developed in Islam and later in Europe, such calculations were generally done by the old, tried and true, methods based on similar triangles rather than the advanced trigonometric ones. In China itself, however, it was rare to use trigonometric methods for anything. Trigonometry was introduced to China from India in the eighth century, but did not "take". It does not reappear in China until Western mathematics reached there in the sixteenth century.

Trigonometry in the Islamic World

Trigonometry arrived in the Islamic world also in the eighth century when an Indian Siddhanta was brought to Baghdad and translated into Arabic. Unlike the case in China, the Islamic scholars welcomed it and rapidly improved on it. By the ninth century, all of the trigonometric functions were tabulated and the basic relationships among them were known. (Again, since one of the primary uses of trigonometry was for astronomical purposes, the names for the functions other than sine and cosine reflected their use here. Thus the words for tangent, cotangent, secant, cosecant are reversed shadow, direct shadow, hypotenuse of the reversed shadow, and hypotenuse of the direct shadow.

The mathematician Abu l-Wafa (10th century) can be regarded as the first

to have calculated modern trigonometric functions, because he used a circle of radius 1. In fact he stated the sum and difference formulas in a very simple way:

Calculation of the sine of the sum of two arcs and the sine of their difference when each of them is known, Multiply the sine of each of them by the cosine of the other, expressed in sixtieths, and we add the two products if we want the sine of the sum of the two arcs, but take the difference if we want the sine of their difference.

Interestingly, in Islam, as had been the case in India, although trigonometry was used for astronomical purposes, older methods were generally used for surveying on the earth. For example, let us consider al-Biruni's work, On Shadows. Al-Biruni knew perfectly well how to solve triangles via trigonometry:

If we are given the shadow at a certain time and we want to find the altitude of the sun for that time, we multiply the shadow by its equal and the gnomon by its equal and we take the square root of the sum, and it will be the cosecant. Then we divide by it the product of the gnomon by the total sine and there comes out the sine of the altitude. We find its corresponding arc in the sine table and there comes out the altitude of the sun at the time of that shadow.

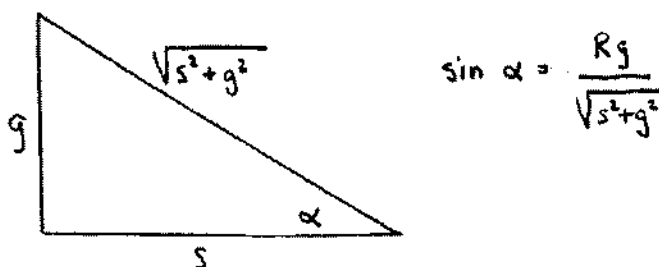

But when we turn later in the same book to a chapter entitled "On the Determination of Terrestrial Distances and the Heights of Mountains by the Use of Shadows," here is what we find:

If surveyed at a time when the altitude of the sun equals an eighth of a revolution (45 degrees) there will be between the end of the shadow [of the desired high object] and the foot of the vertical a distance equal to the height.

If the base of the object is inaccessible, however, al-Biruni suggests, among other methods, that we place a gnomon at two different locations and sight the top of the object. The distance and height are then given by a method similar to the Indian one discussed earlier.

Al-Biruni did provide, however, an elegant trigonometric method for measuring the radius of the earth. His particular measurement showed that the height of the mountain was 652,318 cubits and the angle $\alpha = 34'$. The formula then gives for the radius of the earth 12,803,337; 2,9 cubits.

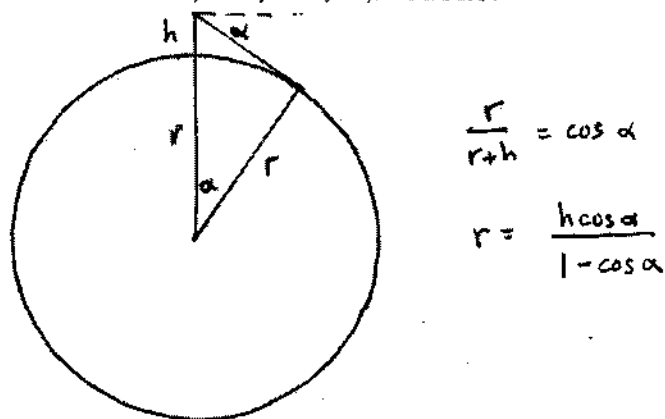

Abu l-Wafa's result and the results of al-Biruni were included in astronomical works, where trigonometry played an important role. It was not until the thirteenth century, however, that a comprehensive and systematic work on trigonometry was published in Islam, the *Treatise on the Transversal Figure* by Nasir al-Din al-Tusi (1201-1274). It was in this work that we first see the sine law for plane triangles proved and then systematically used to solve triangles. We consider al-Tusi's proof:

Sine Theorem: If ABC is any triangle, then $c/b = \sin C/\sin B$.

Prolong CA to D and BA to T so each is of length 60 and, with centers B, C, draw the circular arcs TH and DE. Now drop perpendiculars TK and DF to the base BC extended. Then $TK = \sin B$ and $DF = \sin C$. Draw AL perpendicular to BC. Because triangles ABL, TBK are similar, $AB/AL = TB/TK$, and since triangles ACL and DCF are similar, $AL/AC = DF/DC$. But $DC = 60 = TB$, so if we multiply these two proportions together, we obtain $AB/AC = DF/TK$. Therefore $c/b = \sin C/\sin B$ as desired.

166

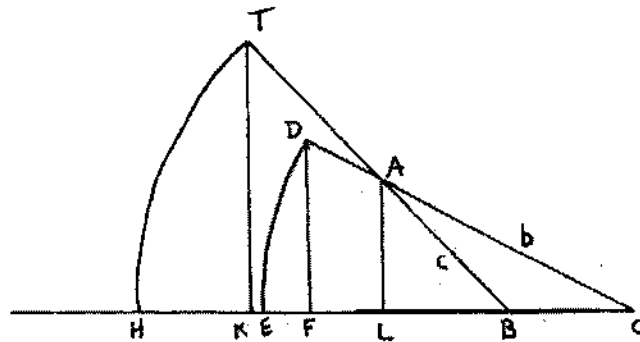

Clearly, however, since the Islamic scholars were interested in trigonometry for astronomical purposes and for computing such quantities as the qibla, the direction to Mecca in which to pray, they were more interested in spherical trigonometry than in plane trigonometry. Various Islamic scholars succeeded in simplifying Ptolemy's methods for solving spherical triangles, both by using the other functions besides the sine and by deriving new theorems. The two basic results are the "rule of four quantities" and the law of sines, both proved by Abu l-Wafa in Baghdad in the late 10th century.

Theorem (Rule of Four Quantities): If ABC and ADE are two spherical triangles with right angles at B, D respectively and a common acute angle at A , then $\sin BC : \sin CA = \sin DE : \sin EA$.

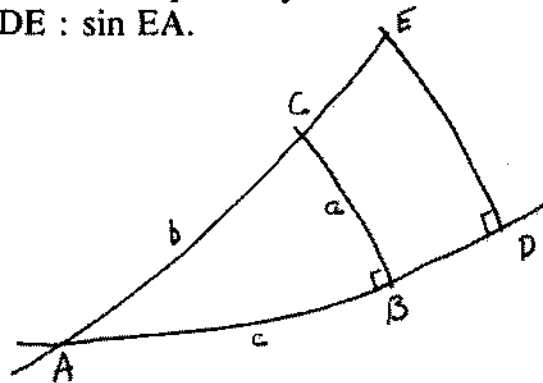

Theorem (Sine Law): In any spherical triangle ABC , $\sin a / \sin A = \sin b / \sin B = \sin c / \sin C$.

Just to see how this works and some of the basic concepts needed in spherical trigonometry, let us consider the proof of the Sine Law. We are given the spherical triangle ABC . Let CD be an arc of a great circle perpendicular to AB . Extend AB and AC to AE and AZ , both quadrants; and extend BA to BH and BC to BT , also both quadrants. Then A is a pole for the great circle EZ and B a pole for the great circle TH . Then the angles E, H are both right and the triangles

ADC and AEZ are spherical right triangles with a common angle at B. By the rule of four quantities, we have

$$\frac{\sin DC}{\sin b} = \frac{\sin ZE}{\sin ZA}$$

and

$$\frac{\sin DC}{\sin a} = \frac{\sin TH}{\sin TB}$$

But A and B are poles of ZE and TH respectively, so arc ZE equals angle A and arc TH equals angle B. We can then rewrite the above equations as

$$\frac{\sin DC}{\sin b} = \frac{\sin A}{1}$$

and

$$\frac{\sin DC}{\sin a} = \frac{\sin B}{1}$$

By eliminating $\sin DC$ from both sides, we get the desired result.

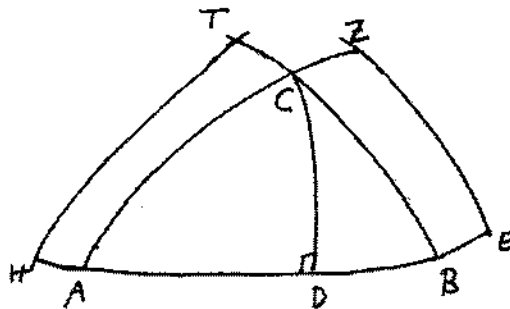

Just as in the case of plane triangles, the sine theorem makes it possible to solve certain triangles. In fact, al-Biruni used the sine theorem extensively in his procedure to find the qibla, the direction of Mecca relative to one's own location in which a Moslem must face during prayer.

Trigonometry in Europe

We want to conclude this survey with a brief discussion on how trigonometry, both plane and spherical, reached Europe. Two of the earliest trigonometry works in Europe were those of Richard of Wallingford (1291-1336) in England and Levi ben Gerson (1288-1344) in France. Both of these works were written as preparation for the study of astronomy. But it does not appear that either had much influence later, nor do we know definitively the sources either man used. From the what appears in their books, however, they both evidently were familiar with Ptolemy's work as well as with some Islamic sources. A work that we know had influence was that of Regiomontanus (1436-1476). His *De Triangulis Omnimodis (On Triangles of Every Kind)* was written about 1463, but not published until 70 years later. It was the first pure trigonometrical work to be written in Europe, even though it was written as a necessary preface to the study of astronomy, particularly of the *Almagest*. But a careful reading of some parts of Regiomontanus's work - particularly the parts on spherical trigonometry - has convinced historians that Regiomontanus himself was heavily dependent on Islamic trigonometry, in particular on the work of Jabir Ibn Aflah, who lived in Spain in the first half of the twelfth century. Jabir's spherical trigonometry included the two basic theorems of Abu l-Wafa above, but it does not seem that Jabir knew directly of Abu l-Wafa's work, because his treatment is considerably different. We do not, in fact, know Jabir's own sources; he may have developed the material based on his own reading of Ptolemy or, more probably, on some of the earlier Islamic modifications. In any case, Jabir's work was translated into both Latin in the mid twelfth century and into Hebrew in the late thirteenth century. It is referred to by Richard of Wallingford and it may also have influenced Levi. But even in the sixteenth century, various authors noted how closely Regiomontanus followed Jabir and even accused him of plagiarism. (Of course, it was not unusual at the time for writers to neglect to mention their sources.)

After Regiomontanus, roughly a score of other works on trigonometry appeared in the last two-thirds of the sixteenth century, many quite similar to his work. Some authors improved his tables, which had been calculated to a radius of 60000, and included tables of all of the other trigonometric functions, whereas Regiomontanus had only used the sine. (Note that, in general, sines as well as tangents and secants were defined as lengths of certain lines depending on a given arc in a circle of a fixed radius.) Because decimal fractions were not yet in general use, it was necessary to use large values of the radius to enable all values of the trigonometric functions to be given in integers. The first author to use the modern terms "tangent" and "secant" was Thomas Finck (1561-1656) in his work of 1583. He called the three co-functions "sine complement," "tangent

complement," and "secant complement." And although many of the trigonometry texts of this period gave various numerical examples to illustrate methods of solving plane and spherical triangles, not until the work of Bartholomew Pitiscus (1561-1613) in 1600 did there appear any problem in such a text explicitly involving the solving of a real plane triangle on earth, in a way similar to the methods in modern trigonometry texts. Pitiscus, in fact, invented the term "trigonometry" and titled his book *Trigonometriae sive, de dimensione triangulis, Liber*.

Trigonometric calculations were made easier with the introduction of logarithms early in the seventeenth century, but it was not until the early eighteenth century that Leonhard Euler introduced our current notion of trigonometric ratios, by standardizing the circle to have radius 1. And, although the power series for various trigonometric functions were known to Newton and Leibniz in the late seventeenth century, it was Euler who really developed the idea of the trigonometric functions as functions of a real variable over the entire real line. In fact, he was forced to consider these functions in connection with his solution of linear differential equations with constant coefficients.

We conclude by noting that trigonometry began in Greece, was worked out in detail in Egypt, traveled to India where it was improved on, traveled back to the middle east, where it was further improved on, and then returned to Europe in its new and improved version via Spain.

HISTOIRE DU CONCEPT DE NOMBRE.

par Éliane Cousquer, IREM de Lille (U.S.T.L. France).

Les nombres dans l'enseignement

Les nombres ont deux usages : compter et mesurer. C'est pourquoi, deux questions sont étroitement liées, aussi bien dans l'enseignement que dans l'histoire : Qu'est-ce qu'un nombre ? Qu'est-ce que la mesure des grandeurs ?

Dans l'enseignement, les jeunes découvrent progressivement les différents nombres. À l'école primaire, ils apprennent les entiers, les fractions et les décimaux, en étroite relation avec la mesure des grandeurs. Au collège, ils découvrent les négatifs, les racines carrées à l'occasion du théorème de Pythagore, et l'usage magique et incontrôlé des calculettes. Au lycée, on leur signale parfois la propriété de transcendance de e , π , sans que cela signifie grand chose pour eux. Et bien sûr, les nombres complexes sont étudiés en liaison avec la géométrie.

De nombreux problèmes se font jour : $\frac{13}{7}$, $\sqrt{2}$ sont-ils des nombres ou l'indication d'un calcul à effectuer ? La distinction entre les décimaux et les développements illimités n'est pas faite ; tous deviennent indistinctement des « nombres à virgule » . Que signifie un développement décimal illimité dont on ne connaîtra jamais qu'un nombre fini de décimales ? Une quantité qu'on peut seulement approcher est-elle un nombre ?

Il y a là une difficulté fondamentale : Comment développer une intuition juste des nombres au travers de l'enseignement primaire et secondaire, sachant que nous ne pourrions pas entièrement les justifier ?

À l'université, cette justification était faite en première année d'université. Autrefois le corps \mathbb{R} était construit à partir du corps des rationnels \mathbb{Q} , soit par la méthode des coupures, soit par les suites de Cauchy. Aujourd'hui cette construction n'est plus faite à aucun niveau à l'université. Un jeune enseignant sortant actuellement de l'université n'a jamais eu la réponse à la question :

QU'EST-CE QU' UN NOMBRE RÉEL ?

L'histoire des mathématiques est particulièrement éclairante sur cette question. Comment notre notion de nombre réel est-elle issue après plus de deux millénaires d'évolution, des questions qu'ont posées les mathématiciens grecs à propos de la mesure des grandeurs et des réponses qu'ils ont apportées ? C'est cette histoire que nous allons présenter dans la suite de l'article, en trois parties :

- La théorie des proportions.
- De la théorie des proportions à la notion de nombre réel.
- La création des nombres réels

LA THÉORIE DES PROPORTIONS.

Civilisations antiques et irrationalité.

Parmi les civilisations antiques, seule la civilisation grecque a eu le souci de développer des démonstrations rigoureuses. Cela les a conduit à découvrir le problème de l'irrationalité. D'autres civilisations antiques, babylonienne et égyptienne, ont développé des mathématiques riches, fait des calculs d'aires et de volumes sans que cette question n'apparaisse. Sans doute à la suite de leurs découvertes en musique, les pythagoriciens ont développé toute une philosophie basée sur le nombre entier. « *Tout est nombre* ». Ils ont fait des démonstrations en géométrie, initialement en utilisant la propriété que deux longueurs quelconques sont commensurables. La découverte, au sein de l'école pythagoricienne de l'irrationalité, introduit une rupture : elle ruine la philosophie pythagoricienne et elle marque un tournant dans l'histoire des mathématiques.

Irrationalité et processus infini.

La découverte de l'irrationalité pose une question fondamentale : si le rapport de deux longueurs ne peut pas se ramener au rapport de deux entiers, comment définir un tel rapport ? Une première réponse a été de le définir par la suite des quotients entiers qui apparaissent dans l'algorithme que nous appelons algorithme d'Euclide, et qui était plutôt appelé algorithme d'antiphérèse, (c'est-à-dire algorithme de soustraction réciproque). Si les deux grandeurs sont commensurables, la suite des quotients entiers est finie. Si les deux grandeurs sont incommensurables, cette suite est infinie. Dès l'origine, la notion d'irrationalité est donc associée à celle de processus infini.

Nature de l'infini.

Les écoles philosophiques grecques se divisent sur la nature du continu : *Le continu est-il indéfiniment divisible ?* et débattent sur la nature de l'infini : *L'infini est-il acceptable en mathématiques ? Quel usage peut-on en faire ?*

Les réponses à ces questions adoptées par la mathématique grecque classique et en particulier par le philosophe Aristote détermineront les mathématiques jusqu'à la fin du dix-neuvième siècle :

- le continu est indéfiniment divisible,
- seul l'infini potentiel est acceptable,
- l'infini actuel est rejeté.

Le rejet de l'infini actuel entraîne la nécessité de trouver une autre définition du rapport des grandeurs incommensurables que celle donnée par la suite infinie des quotients dans l'algorithme d'antiphérèse. On trouve cette définition, attribuée à Eudoxe, dans le livre 5 des *Éléments* d'Euclide, consacré aux rapports de grandeurs.

Les grandeurs dans les « Éléments » d'Euclide.

Les grandeurs ne sont nulle part définies dans les Éléments d'Euclide. Par le contexte, nous voyons les notions d'égalité, de comparaison et de rapport de grandeurs fonctionner pour des segments (désignés par le mot droite), des figures planes, (triangles, rectangles, cercles, polygones, morceaux de plan), des solides, (pyramides, sphères, polyèdres), des angles rectilignes plans, des arcs d'un cercle. On dit qu'une grandeur en mesure une autre si la seconde est obtenue en juxtaposant un certain nombre entier de fois la première. Les opérations sur les grandeurs sont

- liées à la juxtaposition : Additionner deux grandeurs de même nature : les juxtaposer. Multiplier une grandeur par un entier n : juxtaposer n grandeurs égales à la grandeur donnée.
- ou liées à un produit de grandeurs : produit de deux longueurs : construire le rectangle sur ces deux longueurs ; application d'une surface sur une longueur : trouver un rectangle égal à cette surface, dont le côté est la longueur donnée, (sorte de division) ; produit de trois longueurs, (ou d'une surface et d'une longueur) : construire le parallélépipède droit sur ces trois longueurs, (ou sur cette surface et la longueur donnée). Un produit de plus de trois longueurs ou de deux surfaces, etc... n'a donc pas de sens.

La théorie des proportions dans le livre V des « Éléments » .

- 3 Un rapport est une relation telle ou telle selon la taille, (qu'il y a) entre deux grandeurs du même genre, (homogènes).
- 4 Des grandeurs sont dites avoir un rapport l'une relativement à l'autre, quand elles sont capables, étant multipliées, de se surpasser l'une l'autre.
(On reconnaît ici l'axiome dit d'Archimède).
- 5 Des grandeurs sont dites être dans le même rapport, une première relativement à une deuxième et une troisième relativement à une quatrième, quand des équi-multiples de la première et de la troisième dépassent ou sont simultanément égaux ou simultanément inférieurs à des équi-multiples de la deuxième et de la quatrième, selon n'importe quelle multiplication, chacun à chacun, et pris de manière correspondante.
- 6 Et que les grandeurs qui ont le même rapport soient dites en proportion.

Quel est le sens de la définition 5 ? Soient quatre grandeurs données A, B, C, D ; A et B sont de même nature, C et D aussi. On dit que A, B, C, D sont en proportion, ou encore que A et B sont dans le même rapport que C et D , si étant donnés deux entiers quelconques n et p , on est toujours dans l'un des trois cas suivants :
($nA > pB$ et $nC > pD$) ou ($nA = pB$ et $nC = pD$) ou ($nA < pB$ et $nC < pD$).
Beaucoup plus tard cette proportion sera notée : $A : B :: C : D$ ou $A/B = C/D$

La définition 5 est opératoire et sert dans la démonstration par exemple de la proposition 1 du livre 6 : *Les triangles et les parallélogrammes qui sont sous la même hauteur sont l'un relativement à l'autre comme leurs bases.*

Les méthodes de démonstration dans les « Éléments »

La méthode des aires consiste à passer, pour démontrer des égalités entre lignes, (respectivement des égalités de rapports de lignes), par des égalités d'aires, (respectivement des égalités de rapports d'aires). La méthode des aires est utilisée par exemple dans la proposition 2 du livre 6. *Si une certaine droite est menée parallèle à l'un des côtés d'un triangle, elle coupera les côtés du triangle en proportion ; et si les côtés du triangle sont coupés en proportion, la droite jointe entre les points de section sera parallèle au côté restant du triangle.*

La méthode d'exhaustion est une méthode par inventaire de cas. Elle consiste à montrer une égalité ou une égalité de rapports en faisant une double démonstration par l'absurde : le premier (rapport) ne peut être plus grand que le second, ensuite, le premier (rapport) ne peut être plus petit que le second, il y a donc égalité. Cette méthode est utilisée par exemple dans la proposition 2 du livre 12 : *Les cercles sont entre eux comme les carrés de leurs rayons*

— On démontre que $C/C' > R^2/R'^2$ est impossible.

— On démontre que $C/C' < R^2/R'^2$ est impossible.

— On en déduit que $C/C' = R^2/R'^2$

Euclide utilise pour ces démonstrations l'existence d'une quatrième proportionnelle, démontrée seulement dans le cas des longueurs.

Quadratures et cubatures dans les « Éléments » d'Euclide.

Quarrer une surface plane, c'est construire à la règle et au compas un carré égal à la surface donnée. Cuber un solide, c'est construire à la règle et au compas, le côté d'un cube égal au solide donné. La notion de quadrature au sens associer à une surface et à une unité d'aire un nombre n'existe pas chez Euclide. On ne trouve aucune formule de calcul d'aire ou de volume, bien que de nombreux problèmes de quadrature et de cubature soient traités.

La théorie des proportions dans les « Éléments » d'Euclide : bilan.

1. d'une façon générale, en simplifiant, on peut dire qu'on n'opère pas sur les rapports de grandeurs, (à une exception près, rapport "double", rapport "triple"). On compare des rapports de grandeurs, en établissant des égalités ou des inégalités de rapports.
2. Les problèmes de quadratures et de cubatures sont traités dans ce cadre de la théorie des rapports de grandeurs, de façon purement géométrique.
3. Dans les livres 7 à 9 d'arithmétique, sont établies les propriétés des entiers et des rapports d'entiers. Certaines propriétés des proportions sont donc établies

deux fois : une fois pour les grandeurs au livre 5 et une fois pour les nombres (entiers) au livre 7.

4. Le livre 10 introduit la notion de *grandeurs commensurables* qui ont entre elles la raison qu'un nombre a avec un nombre, et de *grandeurs incommensurables* qui n'ont pas entre elles la raison qu'un nombre a avec un nombre.

Fin de la période classique grecque et problèmes légués par les grecs.

À la fin de la période classique grecque, la notion de nombre est étendue aux fractions, d'autres quadratures et cubatures sont démontrées (Archimède), des approximations d'irrationnelles par des fractions sont réalisées, (Héron). Mais pour les grecs le comptage relève du numérique et la mesure des grandeurs relève de la géométrie, sauf éventuellement dans le cas des grandeurs commensurables. Deux questions sont léguées à leurs successeurs :

Quelle est la nature de ces rapports géométriques, qu'on peut encadrer par des nombres, approcher autant qu'on veut par des nombres ?

Peut-on donner une définition plus simple des rapports et des proportions que celle d'Euclide ?

DE LA THÉORIE DES PROPORTIONS À LA NOTION DE NOMBRE RÉEL : Quelques jalons pour deux millénaires d'évolution.

Les calculs sur les rapports.

Dans le livre "De proportionibus proportionum" (milieu du quatorzième siècle) Oresme développe les opérations sur les rapports : ajouter, soustraire, diminuer des rapports ; composer des rapports, (multiplication) ; faire un rapport de rapports, voir s'il est ou non rationnel ; entre deux rapports, insérer une moyenne. Les rapports se comportent comme des grandeurs continues ; entre deux rapports, il est possible d'insérer autant de moyennes que l'on voudra. Les rapports ont donc des propriétés opératoires semblables à celles des nombres.

L'invention des décimaux.

Les décimaux ont une importance considérable pour l'unification du champ numérique. Ils furent inventés à plusieurs reprises, de façon indépendante, semble-t-il. Il y eut invention par les arabes, avec l'apparition de fractions décimales chez Al Uqlidisi (952), avec une théorie des décimaux chez Al Samawal (1152), ainsi qu'une théorie des décimaux chez Al Kasi "clef de l'arithmétique" (1427). Suite à ce travail, le calcul à l'aide de fractions décimales semble avoir été assez répandu en Turquie au quinzième siècle. Il y eut ensuite réinvention des décimaux en Europe au seizième siècle : par Regiomontanus Borge (1484), Rudolf (1525) et Stevin, "La Disme" (1585). L'amélioration des notations avec l'utilisation de la virgule date de Pitiscus (1612) et de Napier (Neper). L'usage des tables de logarithmes de Neper 1550-1617, et de Briggs 1561-1631 entraîne la familiarisation avec les décimaux.

Les développements décimaux illimités sont plus tardifs : (John Marsh 1742). Plus tard, certains voudront les utiliser pour considérer les irrationnels comme des nombres définis par un développement décimal illimité. Cependant leur usage posera les questions suivantes : le développement décimal illimité des fractions est périodique ; il y a une loi pour écrire les chiffres ; le développement décimal illimité des irrationnels n'a pas de loi ; n'est ce pas un objet vide ?

Le développement de l'algèbre.

L'invention de l'algèbre fut une contribution essentielle des arabes. Son développement en Europe avec les algébristes italiens, l'élaboration lente d'un symbolisme algébrique jouent un rôle dans le développement de la notion de nombre réel, en amenant un calcul uniforme, que l'inconnue porte sur des nombres (rationnels), ou sur des grandeurs.

Viète, dans *l'art analytique* 1591 décrit l'art analytique (en fait l'algèbre), comme procédé de découverte en mathématiques. Il distingue *la logistique numérique*, et *la logistique spécieuse*, calcul sur *les espèces* (les inconnues, nombres ou grandeurs). Il utilise les lettres aussi bien pour les coefficients (consonnes), que pour les inconnues, (voyelles). Viète conserve la hiérarchie des grandeurs, longueurs, plans, solides, mais il ajoute des grandeurs de dimensions quelconques, 4, 5, 6... Il associe des inconnues de dimensions quelconques, inconnue, carré, cube, carré-carré, carré-cube, cubo-cube, etc... Viète conserve la loi des homogènes et n'écrit que des égalités entre grandeurs de même dimension. Par exemple, (en utilisant nos notations) : $X^3 + BX = CX^2 + D$ où B est un plan, C est une longueur, D est un solide. Viète établit une équivalence entre égalité de rapports de grandeurs et équations, pour des grandeurs de dimensions quelconques.

$$\frac{A}{B} = \frac{C}{D} \iff AD = BC$$

Représenter toutes les grandeurs par des longueurs.

Dans sa *géométrie* de 1637. Descartes abandonne la loi de l'homogénéité, et représente toutes les grandeurs (les rapports géométriques, les produits, les aires, les volumes, les racines) par des longueurs, après choix d'une unité. C'est un premier pas très important vers la numérisation des rapports de grandeurs. Toutes les grandeurs sont représentées par des segments.

Les rapports sont-ils des nombres ?

Réponse de Stevin dans *l'arithmétique universelle* 1585. Il présente des thèses : Thèse 1 : *que l'unité est nombre*, Thèse 2 : *que nombres quelconques peuvent être nombres carrés, cubiques, de quatre quantités, etc...* Thèse 3 : *qu'une racine quelconque est nombre*, Thèse 4 : *qu'il n'y a aucuns nombres absurdes, irrationnels, inexplicables, ou sourds*.

Arnauld-Nicole dans *la logique ou l'art de penser* (1662), consacre le chapitre 5 à la réfutation de Stevin. En voici la conclusion : « *Le même Stevin est plein de sem-*

blables disputes sur les définitions des mots comme quand il s'échauffe pour prouver que le nombre n'est point une quantité discrète ; que la proportion des nombres est toujours arithmétique et non géométrique ; que toute racine, de quelque nombre que ce soit, est un nombre. Ce qui fait voir qu'il n'a point compris proprement ce qu'était une définition de mot et qu'il a pris les définitions des mots, qui ne peuvent être contestées, pour les définitions des choses que l'on peut souvent contester avec raison. »

Réponse de Pascal dans *De l'esprit géométrique* (1657) « ... C'est ce que la géométrie enseigne parfaitement. Elle ne définit aucune de ces choses, espace, temps, mouvement, nombre, égalité, ni les semblables qui sont en grand nombre, parce que ces termes-là désignent si naturellement les choses qu'ils signifient, à ceux qui entendent la langue, que l'éclaircissement qu'on en voudrait faire apporterait plus d'obscurité que d'instruction. »... « De même, quelque grand que soit un nombre, on peut en concevoir un plus grand, et encore un qui surpasse le dernier ; et ainsi à l'infini, sans jamais arriver à un qui ne puisse être augmenté. Et au contraire, quelque petit que soit un nombre, comme la centième ou la dix millième partie, on peut en concevoir un moindre, et toujours à l'infini, sans arriver au zéro ou néant. »... « Car, afin qu'on entende la chose à fond, il faut savoir que la seule raison pour laquelle l'unité n'est pas au rang des nombres est qu'Euclide et les premiers auteurs qui ont traité l'arithmétique ayant plusieurs propriétés à donner qui convenaient à tous les nombres hormis l'unité ... ont exclu l'unité de la signification du mot nombre ... » « au contraire l'unité se met quand on veut au rang des nombres, et les fractions de même ... puisque l'unité peut, étant multipliée plusieurs fois, surpasser quelque nombre que ce soit, elle est de même genre que les nombres ... » « le zéro n'est pas du même genre que les nombres, parce qu'étant multiplié, il ne peut les surpasser... »

Réponse de Newton dans *l'arithmétique universelle* (1707) « On entend par nombre, moins une collection de plusieurs unités, qu'un rapport abstrait d'un quantité quelconque à une autre de même espèce, qu'on regarde comme l'unité. Le nombre est de trois espèces, l'entier, le fractionnaire et le sourd. L'entier est mesuré par l'unité ; le fractionnaire par un sous-multiple de l'unité ; le sourd est incommensurable avec l'unité. »

Réponse de l'encyclopédie Diderot D'Alembert

Nombre « se dit vulgairement dans l'arithmétique, d'une collection ou assemblage d'unités ou de choses de même espèce. » « M. Newton définit plus précisément le nombre, non pas une multiplicité d'unités, comme Euclide mais le rapport abstrait d'une quantité à une autre de même espèce, que l'on prend pour l'unité... » (... trois sortes de nombres...) « Wolf définit le nombre, ce qui a le même rapport avec l'unité qu'une ligne droite avec une autre ligne droite : ainsi, en prenant une ligne droite pour une unité, tout nombre peut être appréhendé par quelque autre ligne droite ; ce qui revient à la définition de M. Newton. » Les cinq pages suivantes sont consacrées

aux entiers et un peu aux rationnels.

Commensurable : « les quantités commensurables en mathématiques sont celles qui ont quelque partie aliquote commune, ou qui peuvent être mesurées par quelque mesure commune, sans laisser aucun reste, ni dans l'une ni dans l'autre ». . . « Les nombres commensurables sont ceux qui ont quelque autre nombre qui les mesure, ou qui les divise sans aucun reste ». . . « Les nombres commensurables sont proprement les seuls et vrais nombres. En effet, tout nombre renferme l'idée d'un rapport... et tout rapport réel entre deux quantités suppose une partie aliquote qui leur soit commune... $\sqrt{2}$ n'est point un nombre proprement dit, c'est une quantité qui n'existe point, et qu'il est impossible de trouver. Les fractions même ne sont des nombres commensurables, que parce que ces fractions représentent proprement des entiers... » (en prenant les parts pour véritable unité...). « De là, on peut conclure que non seulement les nombres commensurables sont proprement les seuls et vrais nombres, mais que les nombres entiers sont proprement les seuls et vrais nombres, puisque tous les nombres sont proprement des nombres entiers. »

Incommensurable : « se dit de deux quantités qui n'ont point de mesure commune, quelque petite qu'elle soit, pour mesurer l'une et l'autre. Le côté d'un carré est incommensurable avec la diagonale... » « Il y a cette différence entre les incommensurables et les imaginaires, que les incommensurables peuvent se représenter par des lignes (comme la diagonale du carré), quoiqu'ils ne puissent s'exprimer exactement par des nombres, au lieu que les imaginaires ne peuvent ni se représenter, ni s'exprimer. Qu'on approche des incommensurables autant qu'on veut par le calcul, ce qu'on ne peut faire avec des imaginaires. »

Réponse de D'Alembert en 1759 : « Cette facilité qu'on a de représenter les rapports incommensurables non par des nombres exacts, mais par des nombres qui en approchent aussi près qu'on voudra sans jamais exprimer rigoureusement ces rapports, est cause que les mathématiciens aient étendu la dénomination de nombres aux rapports incommensurables, quoiqu'elle ne leur appartienne qu'improprement, puisque les mots nombre et nombrer supposent une dénomination exacte et précise dont ces sortes de rapports ne sont pas susceptibles. Aussi n'y a-t-il à proprement parler que deux sortes de nombres, les nombres entiers et les nombres rompus ou fractions... »

Réponse de Legendre, Éléments de géométrie 1794 qui développe le « vrai sens des proportions » au livre 3. « Si on a la proportion $A : B :: C : D$, on sait que le produit des extrêmes $A.D$ est égal au produit des moyens $B.C$. Cette vérité est incontestable pour les nombres ; elle l'est aussi pour des grandeurs quelconques, pourvu qu'elles s'expriment, ou qu'on les imagine exprimées en nombres ; et c'est ce qu'on peut toujours supposer : par exemple, si A, B, C, D sont des lignes, on peut imaginer qu'une de ces quatre lignes ou une cinquième, serve à toutes de commune mesure et soit prise pour unité ; alors, A, B, C, D représentent chacune un certain nombre

d'unités, entier ou rompu, commensurable ou incommensurable, et la proportion entre les lignes A, B, C, D devient une proportion de nombres. »

Réponse de Kästner, un précurseur, (1758). Kästner se propose de définir les nombres réels indépendamment de la théorie des proportions, de façon purement arithmétique. *« Tous les concepts de l'arithmétique sont, à mon avis fondés sur les nombres entiers ; les fractions sont des nombres entiers dont l'unité est une partie du tout pris au début pour l'unité, et les nombres irrationnels sont des fractions dans lesquels cette unité est une partie variable, de plus en plus petite du tout. »* . . . *« On peut considérer le nombre irrationnel comme étant composé de deux parties : l'une, le commencement, est rationnelle et peut être prolongée à volonté de telle sorte que l'autre partie, la fin, qui reste en toute rigueur toujours inconnue, devienne plus petite que toute grandeur donnée »* . . . *« Si X est un nombre irrationnel, A son commencement rationnel, a sa fin inconnue, alors ce qui est vrai d'un nombre rationnel tel que A, doit aussi être vrai de X, étant donné que cet A peut constituer une partie aussi considérable de X qu'on le désire, par rapport à laquelle a devient de plus en plus petit et peut donc, pour ainsi dire disparaître. »* . . . *« Lorsqu'on divise le 1 sans fin en parties de plus en plus petites et qu'on prend des ensembles de plus en plus grands de ces petites parties, on approche de plus en plus le nombre irrationnel sans jamais l'atteindre complètement. On peut donc le considérer comme un ensemble innombrable de parties infiniment petites. »* . . . *« Celui qui lui dénierait pour cela le nom de nombre devrait faire de même avec les fractions. . . »* Anfangsgründe . . .

LA CRÉATION DES NOMBRES RÉELS

L'arithmétisation de l'analyse

Au dix neuvième siècle se développe le souci de fonder l'analyse sur des bases rigoureuses, (exemple l'oeuvre de Cauchy), et de ne plus justifier les théorèmes fondamentaux de l'analyse par de simples intuitions géométriques, ou des considérations sur le temps et le mouvement (Bolzano). L'analyse ne peut être fondée que sur une justification rigoureuse des propriétés des réels. La solution est de construire les réels en supposant connus les rationnels. Après une première tentative par Bolzano, de nombreux mathématiciens publient, parfois indépendamment une construction des réels.

Ces constructions se rattachent à deux méthodes principales :

— La méthode des coupures de Dedekind est développée dans un cours de 1858 publié en 1872. La construction de Tannery en 1886 se rattache à celle ci quoique Tannery dise l'avoir obtenue indépendamment. Cette méthode présente une parenté profonde avec la théorie des proportions d'Eudoxe Euclide.

— La méthode des suites de Cauchy inventée par Cantor en 1872 est remarquablement explicitée par Heine en 1872. Charles Méray a aussi publié une méthode très proche en 1869 et 1872.

La méthode des coupures

Dedekind présente cette construction dans le petit ouvrage « Continuité et nombres irrationnels » paru en 1872. Dedekind y parle de création des nombres réels. Il introduit les coupures, c'est à dire un partage des rationnels en deux classes tel que tout rationnel de la première soit inférieur à tout rationnel de la seconde. Il montre qu'il existe essentiellement deux sortes de coupures :

— la première classe possède un maximum ou bien la seconde possède un minimum qui est bien sûr un rationnel a . Alors Dedekind considère qu'il s'agit essentiellement de la même coupure définie par le rationnel a , et réciproquement un rationnel définit une telle coupure.

— ou bien la première classe n'a pas de maximum et la seconde n'a pas de minimum. Dedekind montre l'existence d'une telle coupure liée à \sqrt{D} , D nombre entier sans facteur carré. Nous créons un nombre nouveau, irrationnel, x défini par cette coupure (A_1, A_2)

Avec les coupures, Dedekind a donc tous les nombres réels c'est-à-dire les rationnels et les irrationnels. Dedekind définit ensuite une relation d'ordre entre les coupures. Il démontre ensuite la complétude de ce système de nombres : Si le système de tous les nombres réels se subdivise en deux classes $(\mathcal{A}_1, \mathcal{A}_2)$, telle que tout nombre α_1 de la première soit inférieur à tout nombre α_2 de la seconde, alors, il existe un nombre réel et un seul α qui opère cette coupure. Dedekind explique la façon de définir une addition sur les coupures et dit qu'on pourrait aussi définir de la même façon toutes les opérations et démontrer effectivement toutes les propriétés de ces opérations que l'on n'a jamais démontrées, par exemple $\sqrt{2} \times \sqrt{3} = \sqrt{6}$.

Lien entre les coupures et la théorie des proportions Euclide a défini les rapports de grandeurs homogènes, (de même nature), et définit l'égalité de deux rapports de grandeurs (dans notre langage), A est à B comme C est à D , si pour tous les entiers n et p , on a toujours :

$(nA > pB \text{ et } nC > pD)$ ou $(nA = pB \text{ et } nC = pD)$ ou $(nA < pB \text{ et } nC < pD)$

En considérant les rapports $\frac{A}{B}$ et $\frac{C}{D}$ comme des nombres, on peut, en disant que les deux rapports sont toujours placés du même côté de n'importe quel rationnel $\frac{p}{n}$, retrouver pour l'essentiel la théorie des coupures de Dedekind.

La construction par les suites de Cauchy

Une suite de Cauchy de nombres rationnels est définie par une propriété indépendante de toute limite. (u_n) est une suite de Cauchy si, en employant le formalisme actuel :

$$(\forall \epsilon > 0)(\exists N \in \mathbb{N})(\forall n \text{ et } p \in \mathbb{N})((n > N \text{ et } p > N) \implies |u_n - u_p| < \epsilon)$$

On établit une relation d'équivalence sur les suites de Cauchy de rationnels : deux suites u_n et v_n sont équivalentes si la différence $u_n - v_n$ tend vers 0.

Un nombre réel sera défini comme une classe d'équivalence de l'ensemble des suites de Cauchy de rationnels par cette relation d'équivalence. Cette construction

permet d'établir facilement à partir des propriétés des suites, une relation d'ordre et les propriétés de opérations algébriques sur les nombres réels à partir des propriétés des suites. Par contre une démonstration est requise pour montrer que l'ensemble ainsi formé est complet, c'est-à-dire qu'une suite de Cauchy de nombres réels cette fois, ne conduit pas à d'autres nombres, mais converge vers un nombre réel.

Les développements décimaux illimités

On peut définir les nombres réels par des décimaux illimités. Pour résoudre la difficulté posée par l'existence de développements illimités dont les chiffres n'obéissent pas à une loi, Du Bois-Reymond, puis plus tard Lebesgue, passent par la représentation des nombres décimaux par des points sur une droite. Ils conservent donc un lien dans la définition même des réels avec la géométrie.

Les manuels des années 1960 : les grands traités français commencent tous le cours d'analyse par la construction des nombres réels en première année d'université.

Exemples :

— Le livre de Pisot Zamansky (1959) présente la construction par les suites de Cauchy (30 pages).

— Le livre de Cagnac et Ramis (1967) présente la construction par les coupures et démontre avec soin les propriétés des racines jusque là admises au lycée.

— Le livre de Lelong-Ferrand Arnaudies présente la construction des nombres réels par les suites de Cauchy et démontre que tout corps archimédien complet est isomorphe à \mathbb{R} .

Le livre américain de Spivak « Calculus » présente la construction des nombres réels en annexe (chapitre 28) et démontre l'unicité du corps des réels, à isomorphisme près (chapitre 29).

Conclusion

Quand on voit les difficultés qu'ont rencontrées les mathématiciens pour élaborer la notion de nombre réel et penser la mesure des grandeurs, peut-on penser que les élèves et les étudiants mettront un sens à ces notions, à partir d'une introduction implicite et d'une pratique calculatoire ?

Penser l'introduction des nombres et la pratique de la mesure des grandeurs à travers tous les cycles d'enseignement est une nécessité si on veut donner du sens aux mathématiques enseignées.

Avoir soi-même en tant qu'enseignant les idées claires sur ces questions en est une autre, si on veut aider les élèves à acquérir une intuition juste des nombres et comprendre le sens des mathématiques enseignées au lycée et à l'université.

Bibliographie abrégée

Cantor *De l'extension d'une proposition de la théorie des séries trigonométriques* 1872 (disponible à l'Irem de Toulouse)

Cavaillès *Cours de philosophie mathématique* Hermann (publié en 1962)

Cousquer Éliane *De la théorie des proportions à la théorie des nombres réels* Janvier 1995 Irem de Lille

Cousquer Éliane *Les construction des nombres réels* avril 1996 Irem de Lille

Dedekind Richard *Essays on the theory of numbers* Edition Dover 1963 contient deux articles : *Continuity and irrational numbers* 1872 ; *The nature and meaning of numbers* 1887 ; *Continuité et nombres irrationnels* traduction Judith Milner revue par H. Sinaceur (disponible à l'Irem de Toulouse)

D'Alembert *Essais sur les éléments de la philosophie naturelle* 1759

Du Bois-Reymond *Théorie générale des fonctions* 1887 Hermann

Encyclopédie Diderot-D'Alembert

Heine *Les éléments de la théorie des fonctions* dans le journal de Crelle (1872) traduction par JP Friedelmeyer et Guillemot (Irem de Toulouse)

Kästner *Anfangsgründe der arithmetik, geometrie, ebenen und sphärarischen trigonometrie und perspektiv* 1758 édition de 1792 et *eine unzählige Menge unendlich kleiner Theile* cité dans Sebestik Jean *Logique et mathématique chez Bolzano* Vrin

Meray Charles *Remarques sur la nature des quantités définies par la condition de servir de limites à des variables données* publié en 1869 dans la revue des sociétés savantes et *Nouveau précis d'analyse infinitésimale* publié en 1872

Tannery *Introduction à la théorie des fonctions d'une variable réelle* 1886 Hermann

THE HISTORY OF NON-EUCLIDEAN GEOMETRY

Torkil Heiede, Royal Danish School of Educational Studies

The sum of the angles in a triangle and parallelism

If you ask somebody who is not a mathematician to give you a geometric fact it is very probable that you will get the answer that the sum of the angles in a triangle is 180 degrees. But if you put the same question to a mathematician it is possible that you will get another question in return: What do you mean by a geometric fact? This is an interesting difference in attitude: The non-mathematician is ready to supply you with a mathematical fact, while the mathematician puts the whole issue of mathematical facts in doubt. And this in its turn must have something to do with the way the non-mathematician got his or her mathematics, and since this mostly took place in school it could be informative to see how this "geometrical fact" is presented in different textbooks for schools.

In many elementary textbooks each of the pupils is asked to cut out a triangle of coloured paper, tear off the corners, put them together, and see that they (seemingly) fit along a ruler; since this happens for everyone in the whole class, the truth of the statement is evident. There is here no borderline between geometry and physics - the truth of a geometrical assertion is decided by experiment. Sometimes the same idea is expressed a little differently: instead of tearing off the corners one folds them together so that they meet in a point of the base of the triangle, or more subtle, the pupils do not perform this folding on real paper triangles, they are only asked to think of doing it, or to draw pictures of the unfolded and the folded triangle - the experiment has become a thought experiment one can reason about. But of course it is an unspoken assumption that such a folding is possible for all triangles - also in an "imaginary" geometry. And behind this there are assumptions about parallelism: the triangle has been folded into a quadrangle with four right angles, so it is a (hidden) assumption that such rectangles exist, and therefore also parallel lines.

Another argument is also very often met: a small line segment on one of the sides of a triangle is moved about; it is translated along the sides of the triangle and rotated around its corners, and it returns to its original position, seemingly having in all only been rotated through 180 degrees, and the statement follows. But consider a large triangle on the surface of a sphere, the sides being a quarter of the "equator" of the sphere and two quarter-meridians stretching up to the "North Pole"; moving a small arc segment in the same way as before along the sides and around the corners of this triangle back to its original position would seem to show that the angle sum of this triangle is also 180 degrees. However, it is evident that it is 270 degrees, so the argument cannot stand alone. It is only valid together with an (maybe unspoken) assumption on parallelism, namely that parallel translations are at all possible - which they are not on the surface of a sphere, since there are no parallel lines. Two lines - that is: two great circles - always meet, even twice. By the way, on the surface of a sphere no rectangles exist so that we see once more that the argument about folding a triangle contains hidden assumptions on parallelism.

One can also meet more sophisticated versions of the argument - or experiment - on tearing off the corners of a triangle; one can use a tessellation of the plane with congruent triangles where angles from different triangles meet in a point and add up to 180 degrees. But also here parallelism plays an important role without being mentioned: from where does one really know that such parallel strips crossing each other in three directions are possible?

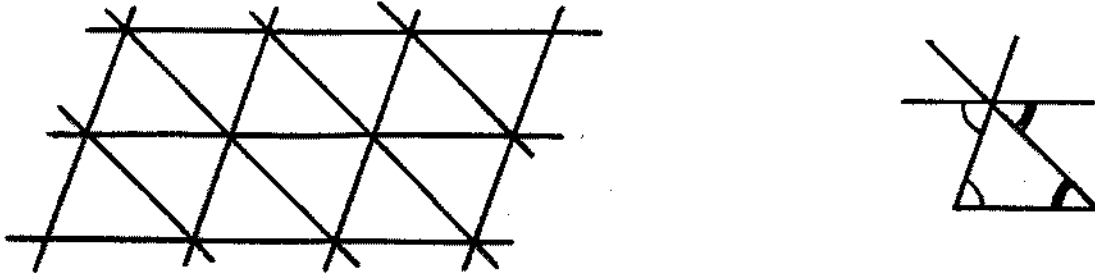

And then there is the classical argument which can still be met also in not quite so elementary textbooks. It involves explicitly a line which is parallel to one of the sides of the triangle and goes through the opposite corner, and using a theorem on angles at parallel lines one sees that the angle at that corner together with two angles congruent to the other two angles in the triangle add up to 180 degrees. Of course this theorem on angles at parallel lines must then be proved first, maybe from other theorems, but finally it must rest on some assumption on parallel lines.

This argument is really classical; it goes straight back to the oldest known source for all this, the treatment given by Euclid (c.300 BC) himself as proposition 32 of Book I of the thirteen in his *Elements*. The most authentic version which exists is still the one constructed more than 100 years ago by Johan Ludvig Heiberg (1854-1928, Danish) from all existing manuscripts. Here is the proposition in the translation by Thomas L. Heath (1861-1940, English) of Heiberg's text:

PROPOSITION 32.

In any triangle, if one of the sides be produced, the exterior angle is equal to the two interior and opposite angles, and the three interior angles of the triangle are equal to two right angles.

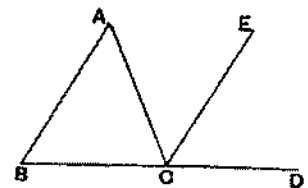

The figure is a little different from the one above, but the idea is the same, and the basic assumption on parallel lines on which the proof rests is Euclid's famous fifth postulate, or axiom, from the beginning of Book I. Here it is, also in Heath's translation from Heiberg:

5. That, if a straight line falling on two straight lines make the interior angles on the same side less than two right angles, the two straight lines, if produced indefinitely, meet on that side on which are the angles less than the two right angles.

It is evident that this has much to do with the sum of the angles in a triangle, for if the two lines Euclid is talking about meet somewhere then the three lines form a

triangle, and if the sum of the three angles in a triangle is always 180 degrees, then the sum of the first two angles is necessarily less than 180 degrees. So what the axiom says is that this is not only necessary but also sufficient for the two lines eventually to meet. And one can add that if the sum of the first two angles is precisely 180 degrees, and if the sum of the three angles in a triangle is always 180 degrees, then there is no room for a third angle, and the two lines cannot meet.

So one might think that everything was in order and there was nothing to worry about. But right from the beginning Euclid's parallel axiom was in some discredit. All his other axioms talked of something which could be seen as taking place inside the borders of a sheet of paper:

POSTULATES.

Let the following be postulated :

1. To draw a straight line from any point to any point.
2. To produce a finite straight line continuously in a straight line.
3. To describe a circle with any centre and distance.
4. That all right angles are equal to one another.

In contrast to this, the situation described in the parallel axiom might require one to go very far out to one side to find the intersection point of which it talks. How far? To the wall of Euclid's room in the Museion in Alexandria where he lived and worked, or to the end of Africa, or to the Moon, or further? How could one really be so sure of the truth of such an assertion? And these axioms were all meant to express something which was self-evident!

Attempts to prove the parallel axiom

Even Euclid himself seems to have considered the parallel axiom as something special: While he used the other four axioms freely right from the beginning, the first time he used the parallel axiom was in the proof of Proposition 29, that is just before he reached Proposition 32 on the sum of the angles in a triangle. (Book I contains in all 48 propositions, the last two being the theorem of Pythagoras and its inverse.)

Already in antiquity many mathematicians tried to improve Euclid's *Elements* by proving the parallel axiom from the other axioms and thereby changing it into a theorem. But they had no luck, or if they thought so others were always able to show that they had inadvertently built upon something else which in its turn they could not prove without using the parallel axiom.

There were also some who tried to resolve the problem by altering Euclid's definition of parallel lines:

23. **Parallel** straight lines are straight lines which, being in the same plane and being produced indefinitely in both directions, do not meet one another in either direction.

They exchanged the last sentence with this one:

have the same distance between them in both directions

But if you take all the points equidistant to a line on one side of it, can you then really be sure that they constitute a line? One should think so, but it seemed that in any attempt to prove it one had to use the parallel axiom. From time to time one still encounters this definition, also in school textbooks whose authors probably often do not know that it is really a very bad idea to use it since it clouds the whole issue.

One of the Greeks who tried to prove the parallel axiom was the great astronomer of antiquity, Claudius Ptolemy (or Klaudios Ptolemaios) (c.85-c.165). Another one was the historian of mathematics (one of the first we know) who wrote an elaborate commentary to Book I of Euclid's *Elements*, Proclus (or Proklos) (410-485). He showed this theorem:

If a line meets one of two parallel lines then it also meets the other one

and from this he proved the parallel axiom. But to prove his claim he used this assumption:

The distance between two parallel lines is bounded

One should think that this was evident, but it is not: it really turns out to be equivalent to the parallel axiom. Many other statements have from time to time been tried as substitutes for the parallel axiom. Here are some of them; they have all on closer examination proved to be equivalent to it:

Two lines parallel to the same line are parallel

Through a point outside a line there is at most one line parallel to it (Playfair)

Triangles can be similar without being congruent

Similar triangles of different size exist

Triangles of the same shape but different size exist

Through a point outside two intersecting lines there exists a line meeting both

Every triangle has a circumcircle

Through three different points go either a line or a circle

And among the many mathematicians who through the times since Ptolemy and Proclus proved the parallel axiom from such statements can be mentioned:

Alhazen (965-1041, Arabic)

Omar Khayyam (1048-1131, Persian, the great poet)

Christopher Clavius (1537-1612, German)

Pietro Antoni Cataldi (1548-1626, Italian)

John Wallis (1616-1703, English)

Girolamo Saccheri (1667-1733, Italian)

Johann Heinrich Lambert (1728-1777, German)

Louis Bertrand (1731-1812, Swiss)

John Playfair (1849-1819, Scottish)
Adrian Marie Legendre (1752-1833, French)

There were others, but these seem to be the most important, and among them two stand out: Saccheri and Lambert. They both tried to give an indirect proof of the parallel axiom, and they both believed they had succeeded in this, which they had not. But it was precisely the failure of an indirect proof which later on was so eminently fruitful.

Saccheri and Lambert

Girolamo Saccheri was a logician, and strongly interested in the logic of indirect proofs. Since all direct proofs of the parallel axiom seemed to him not to have worked he tried an indirect one. He began with a quadrangle with two opposite sides of equal length, both orthogonal to the side between them. Omar Khayam had also worked with such quadrangles, but not to the same extent, so today they are most often called Saccheri-quadrangles. Saccheri showed that the two remaining angles are

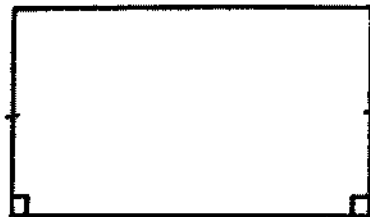

equal, and also that if they are both right angles in one such quadrangle the same will be the case in all such quadrangles, and similarly if they are both obtuse, and also if they are both acute. Now it was clear that if the parallel axiom was true one would have the first of these three cases, and on the other hand Saccheri could show that in the first of the three cases, or, as Saccheri put it: under the hypothesis of the right angle, one could prove the parallel axiom.

Moreover, Saccheri showed that in the second of the three cases, under the hypothesis of the obtuse angle, one could also prove the parallel axiom from which, as already mentioned, the hypothesis of the right angle would follow. So Saccheri had a contradiction: If the two angles were both obtuse, they were both right. Therefore, if he could also deduce a contradiction in the third case, under the hypothesis of the acute angle, he would have given an indirect proof of the parallel axiom.

So this is what Saccheri then started out to do: to draw consequence after consequence from the hypothesis of the acute angle to see if he could end up with a contradiction. He found more such strange consequences than anyone had done who before him had had similar ideas. But even if he found them strange he could not honestly say that they contradicted each other or the axioms (other than the parallel axiom) or other theorems deduced from these, so he continued to draw consequences until he arrived at this one:

The distance between two lines who do not meet can decrease and they will then have a common perpendicular in a point infinitely far away in which they touch each other.

This he deemed to be “repugnant to the nature of the straight line” and took it to be the contradiction he had set out to find. He was, however, not quite content with it and tried to find a better one using the points equidistant to a line on one side of it; and he found one, unfortunately as a result of a mistake in a computation of an arc length. But still he was not satisfied, mainly because he was quite aware that under the hypothesis of the acute angle he could not be sure that these points constituted a straight line. So he finished his book *Euclides ab omni naevo vindicatus* (Euclid vindicated of all blemish) on a note of doubt, comparing the clear contradiction he had reached under the hypothesis of the obtuse angle with the obscure ones he had reached under the hypothesis of the acute angle. Perhaps he wanted to come to a conclusion; the book was in fact published in the year of his death.

Half a century after Saccheri a similar approach was used by Johann Heinrich Lambert, the main difference being that he started from quadrangles with three right angles; the question was then if the fourth angle was right, obtuse or acute. Alhazen had worked with such quadrangles, but today they are mostly known as Lambert-quadrangles. Since a Lambert-quadrangle can be seen as half a Saccheri-quadrangle

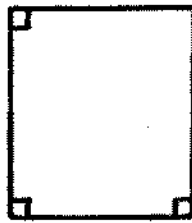

it is not surprising that Lambert was able to show first that the hypothesis of the right angle gives the parallel axiom, next that the hypothesis of the obtuse angle gives a contradiction, and finally that the hypothesis of the acute angle gives a long row of strange consequences. Of these he found more than even Saccheri had found, in particular that in every triangle the sum of the angles is less than 180 degrees. And just as Saccheri he ended up with a contradiction, again something about all points equidistant from a line. But he did not publish anything, so maybe he was not quite convinced after all. His book *Theorie der Parallellinien* (Theory of parallel lines) came out nine years after his death, twenty years after he had written it.

One of Lambert’s most remarkable statements was that one must nearly draw the conclusion that all the strange consequences of the hypothesis of the acute angle were true on an imaginary sphere (just as the consequences of the hypothesis of the obtuse angle are true on a usual sphere). How such an imaginary sphere would look he did not say explicitly.

But one hundred years after Saccheri and fifty years after Lambert three very different mathematicians became convinced (at nearly the same time) that no contradiction would ever appear:

Carl Friedrich Gauss (1777-1855, German, the prince of mathematicians)

Nikolai Ivanovich Lobachevsky (1792-1856, Russian)
János Bolyai (1802-1860, Hungarian)

All three said that one could have a geometry different from the Euclidean geometry whose uniqueness and truth had never been doubted in all the long history from Proclus to Legendre: a geometry in which all the strange consequences of denying the parallel axiom were valid geometric theorems.

Gauss, Bolyai and Lobachevsky

The first to arrive at the conviction that such a non-Euclidean geometry existed was Carl Friedrich Gauss. It probably happened around 1820, but he did not publish anything about it throughout his long life. He only wrote of it for his own pleasure and to a very few correspondents. He was the most famous mathematician of his time, he was quite sure that publication of these thoughts would create controversy, and he would not (as he said) expose himself to the yellings of the Boiotians (in antiquity the people from Boiotia were considered by all other Greeks to be very coarse and not very intelligent). And for this reason Gauss's work on this subject is known only from his notes and from letters published after his death.

János Bolyai was the son of an old friend and fellow student of Gauss, Farkas Bolyai (1775-1856), who had himself worked in vain on the parallel axiom and who had warned his son against having anything to do with it. But in 1823 the son wrote to his father that he had created a strange new world out of nothing. In 1832 he published his discoveries as an appendix in Latin to a large book by his father. This book, also in Latin, was an extensive survey of endeavours to prove the parallel axiom; it is usually called *Tentamen* (Attempt) after the first word in its very long title. The appendix itself also has a long title of which this is only the beginning: *Appendix scientiam spatii absolute veram exhibens* (Supplement containing the absolutely true science of space). It is usual to call it *Science of space* or simply Bolyai's *Appendix*.

Farkas Bolyai sent his book with his son's appendix in it to Gauss who wrote back that he could not praise the work of his old friend's son since that would be self-praise - because he had himself had the same thoughts many years ago. János Bolyai was of course furious, and he never wrote on the subject again. But his father did; in 1851 he published a book, *Kurzes Grundriss eines Versuches ...* (A short sketch of an attempt ...) in which he believed he had proved the parallel postulate. He assumed the truth of the statement we have already mentioned that through three points not on a line passes a circle, which is in fact equivalent to the parallel axiom. Sad to say he had not understood his son's discovery.

Nikolai Ivanovich Lobachevsky spent most of his life in Kazan 720 km directly east of Moscow, on the Volga. He grew up there, he was a student at the University of Kazan (which was founded in 1804 and was regarded as the easternmost university in the world), he became a professor at the same university and was finally for many years its vice-chancellor.

One of Lobachevsky's teachers at the university had been J.M.C.Bartels (1769-1836, German) who was a friend of Gauss. It seems that in 1815-17 Lobachevsky was trying to prove the parallel axiom, but that between 1823 and 1825 he became convinced that such a proof was not possible. He gave his first lecture on his discoveries in 1826 and published his first treatise on them in 1829: *O nachalah geometrii* (On the principles of geometry), in the journal of the Kazan University. So if Lobachevsky was not the first discoverer of non-Euclidean geometry, he was the first to publish on it, but in Russian, and at a place very far away from the mathematical centres of Europe.

Over the years, and in between his many professional and administrative duties, Lobachevsky wrote many articles and books on his imaginary geometry, as he called it, and not only in Russian but also in French and German, without ever attracting the attention it merited; the mathematical world did not care much about what someone in Kazan might think of. It would surely have been different if Gauss had published anything on the subject. However, Lobachevsky sent his book *Geometrische Untersuchungen zur Theorie der Parallellinien* (Geometrical researches on the theory of parallel lines) from 1840 to Gauss who replied appreciatively and saw to that Lobachevsky was elected to become a member of the Scientific Academy of Göttingen.

So three men were in possession of an epoch-making discovery, but nobody really noticed or understood what had happened before an Italian in 1868 proved what these three had only conjectured: that no contradiction would ever occur in this new non-Euclidean geometry (provided that no contradictions were hidden in the old Euclidean geometry, which was considered unthinkable). But then all three discoverers were dead.

Beltrami, Riemann, Klein and Poincaré

Four mathematicians are especially important in the next period of the history of non-Euclidean geometry:

Bernhard Riemann (1826-1866, German)

Eugenio Beltrami (1835-1900, Italian)

Felix Klein (1849-1925, German)

Henri Poincaré (1854-1912, French)

In 1868 Eugenio Beltrami showed that in the Euclidean space geometry one could build a model of the plane geometry of Gauss, Bolyai and Lobachevsky, or in other words: in Euclidean space one can find a surface whose "intrinsic" or "inner" geometry is non-Euclidean, that is: one can on (or rather in) this surface find curves which - taken as the lines of the geometry - satisfy all the Euclidean axioms except the parallel axiom, and instead of that its negation.

If one accepts Euclidean geometry, in the sense that one takes for granted that no contradiction will ever appear in it, then the existence of such a model forces one to acknowledge that no contradiction will ever appear in non-Euclidean geometry either

(since the model is embedded in Euclidean space) - and one is therefore forced to accept also non-Euclidean geometry.

So Beltrami's proof of the existence of such a model was a decisive turn, for until then everybody had understood the matter in this way (if they had at all taken an interest in it) that either was Euclidean geometry true, or non-Euclidean; and since one was convinced of the truth of Euclidean geometry one rejected non-Euclidean geometry. But Beltrami's work showed definitively that if Euclidean geometry was true then non-Euclidean geometry was also true.

And on the other hand already Lobachevsky had known - and maybe a few people before him - that if one imagines a non-Euclidean space, then in it one can find a type of surfaces whose "intrinsic" geometry is Euclidean, so Euclidean and non-Euclidean geometry are equally true. And with this the word 'truth' changes its meaning in mathematics. Until this moment mathematics and especially geometry had been considered as a system of true statements on the world around us, deduced from self-evident truths, but from now on one was forced to regard mathematics quite differently, namely as something one imagines. Also Euclidean space was now not more real than non-Euclidean space - they were both something we (only) imagine - and with this mathematics became an independent science in a new and previously quite unknown way. It became a quite separate science, without counterparts, detached from the natural sciences, more closely related to branches of art such as music and the visual arts, or to a large system of games as for example chess and draughts etc.

In 1854 Bernhard Riemann gave a lecture with the title *Über die Hypothesen, welche der Geometrie zu grunde liegen* (On the hypotheses which are fundamental to geometry); it was published in 1868 after his death. In this lecture Riemann showed something that now could be seen to match perfectly with Beltrami's result, namely that if the other axioms of Euclid are relaxed somewhat then Saccheri's and Lambert's hypothesis of the obtuse angle no longer leads to a contradiction. In this way one then gets a third type of plane geometry, in which there are no parallel lines and where it is a theorem that the sum of the angles in a triangle is more than 180 degrees and less than 900 degrees. A suitable model in Euclidean space geometry for this Riemannian non-Euclidean geometry is simply the "intrinsic" geometry of the surface of a Euclidean sphere in which the great circles are taken as lines. Of course this geometry had been known since antiquity, but no one had seen it in this way before. In counterpoint to this Beltrami's Euclidean surface whose "intrinsic" geometry was a model for the Lobachevskian non-Euclidean geometry became known as a pseudo-sphere: its Gaussian curvature is -1 in every point just as the Gaussian curvature of the usual sphere (with radius 1) is 1 in every point.

It should be mentioned that when Riemann gave his lecture Gauss was in the auditorium, and more than that: the lecture was part of Riemann's doctoral work, and he had (as it was customary) submitted three different subjects for his lecture; one of them was geometrical, and it was Gauss who had decided that this was the one he should speak about.

So now one had three plane geometries, all equally true: the Lobachevskian, the Euclidean and the Riemannian or, as they are also called, the hyperbolic, the

parabolic and the elliptic geometry. This new insight - and also the understanding of its consequences for mathematics as a whole - spread rapidly in the mathematical world in the last quarter of the 19. century. It is significant that the English mathematician William Kingdom Clifford (1845-1879) already in 1872 called Lobachevsky the Copernicus of mathematics - because he had opened a new world. Also it was very important that two of the leading mathematicians of the time, Felix Klein and Henri Poincaré, were both intensely engaged in the non-Euclidean hyperbolic geometry, and in the uses it could - in many surprising ways - be put to in other parts of mathematics. They each constructed a plane Euclidean model (as opposed to Beltrami's model on a curved Euclidean surface) of the Lobachevskian geometry, Klein in 1871, and Poincaré (even in two versions) in 1882. Klein's model uses chords of a Euclidean circle as non-Euclidean lines, and Poincaré's models use respectively diameters and circular arcs of a special type in a Euclidean circle, and half-lines and semicircles in a Euclidean half-plane.

A similar change took place in other parts of mathematics which also contributed to this new understanding. In algebra the correspondence between complex numbers and the points of the plane had been established independently in 1797 by Caspar Wessel (1745-1818, Norwegian), in 1806 by Jean-Robert Argand (1768-1822, Swiss), and at some point in between (but not used explicitly in any of his publications before 1848) by Gauss. Already in 1797 Wessel had tried - in vain - to generalize the complex numbers in such a way that a similar correspondence could be established between this generalization and the points in space, but his paper went unnoticed. In 1837 William Rowan Hamilton (1805-1865, Irish) expressed the same wish - in the paper in which he had interpreted the complex numbers as pairs of real numbers - but his work only bore fruit when in 1843 he discovered that one should not generalize to triplets of real numbers but to quadruples, and so invented his quaternions. By this he did for algebra the same as Gauss, Bolyai and Lobachevsky had done for geometry: If you ask somebody who is not a mathematician to give you an arithmetical fact you might get the answer that the order of the factors (in a product of two numbers) is arbitrary; but this is precisely not the case with the quaternions: their multiplication is not commutative. It is interesting that the two Bolyais, father and son, also tried their hand in this area - from where they lived later in life, in a little town in Transylvania, then in Hungary, now in Rumania.

In our time mathematics really only deals with itself; to a mathematician it is strange (but of course also pleasant) that it can be used to describe phenomena outside mathematics.

Non-Euclidean geometry and physics, philosophy and art

It appears from the previous sections that around 1830 - and effectively from around 1870 - a decisive change took place in mathematicians' understanding of their own science. Geometry was no longer a part of physics - of course one could still use it for description of physical situations and phenomena, but now one could choose among different geometries. This choice is not made by the mathematician but by the physicist, and he should choose the geometry which gives him the best

description - that is the one which fits his experiments or his theory best. He cannot choose the "true" geometry, for mathematically they are equally true.

And in time the mathematicians have given the physicist many geometries to choose among - it may also happen that a new geometry is invented to fit the physicist's specification; this was the case with Einstein's theory of relativity. Even so-called finite geometries have been invented; for instance one can have a "plane" consisting of nine "points" distributed on twelve "lines" with three points on each. Also for such geometries there are eminently practical applications.

For a physicist or some other practician geometry is then now a toolbox for descriptions, and maybe also a guideline for theories, while for a mathematician it is the study of all the many different geometries. They behave differently, and the behaviour of a geometry depends on the choice of fundamental relations between points and lines and planes - and here the mathematician chooses freely and independently. For him geometry is something quite different from the intuitive ideas one can have of the organization of physical space - they can be used for inspiration, but geometries can be built in many ways and can be studied without any regard to physical ideas.

Outside the worlds of mathematics and physics the new geometrical insight spread more slowly, and sometimes under protest - many philosophers even raised very angry protests. One reason why Gauss never published anything on non-Euclidean geometry was probably that the German philosopher Immanuel Kant (1724-1804) in 1781 in his very famous and influential book *Kritik der reinen Vernunft* (Critique of pure reason) had placed Euclidean geometry as an a priori form of comprehension; when Gauss talked of the Boiotians he can very well have meant the numerous students and followers of Kant.

All the time since the inception of non-Euclidean geometry there have been philosophers who could not come to terms with it. Let me mention just one curious example, Kristian Kromann (1846-1925, Danish) who was professor of philosophy at the University of Copenhagen for 38 years (1884-1922) and who lectured on pedagogy at my own institution until 1914. As late as in 1920 he published a small book both in Danish and in English in which he believed he had proved the parallel axiom and thereby refuted non-Euclidean geometry. What he did was just to use the argument one can sometimes meet - as we have seen - in elementary school textbooks, of moving a small line segment along the sides and around the corners of a triangle.

Many artists however seized the new mathematical ideas with great interest. Much of modern art - from cubism to the very newest - would be unthinkable without the original inspiration from non-Euclidean geometry, and also from the geometries of more than three dimensions - both Euclidean and non-Euclidean - which mathematicians began to cultivate in the last years of the 19. century. In this connection one must also mention the graphical artist M.C.Escher (1898-1972, Dutch); many of his striking pictures build directly on Poincaré's circle model of hyperbolic geometry.

Outside the circles of mathematicians, physicists, philosophers and artists, however, there are probably very few who are at all aware of the existence of non-

Euclidean geometries, and this is presumably also true for many mathematics teachers, especially at the primary and lower secondary level where most pupils get their one and lasting impressing of what geometry is.

Non-Euclidean geometry and the mathematics teacher

Many mathematics teachers have not in their own education heard anything about non-Euclidean geometry, and it may therefore come as something of a shock to them that geometry is really not a part of physics and fundamentally does not deal with our physical surroundings, and that geometrical theorems are not true in any straightforward physical sense. It may then be a consolation to know that this also surprised and annoyed many mathematicians when it all began to be known around 125 years ago, and that many of them only with difficulty got accustomed to these new ideas.

But does it matter if a teacher does not know about non-Euclidean geometry, one could ask. Nobody would after all expect him or her to teach it to children. The answer is that it does matter, profoundly. If a teacher knows that geometry is true on its own conditions and not as a sort of physics or a part of it, then this teacher will maybe teach Euclidean geometry differently from how he or she would otherwise have done it. Moreover, a knowledge of the existence of non-Euclidean geometry gives one a different view of what mathematics really is, and this may leave its mark everywhere on one's teaching of mathematics.

Also, in many of the subjects in school - physics, chemistry, biology, literature, history etc. - one tries to be rather up to date: one would like to give the pupils an impression of or a feeling for what goes on in these subjects in our own time. It is very difficult to do the same in mathematics, one of the reasons being that the mathematics that one teaches is not new. Quadratic equations were solved and parabolas were drawn already in antiquity; coordinate systems which created a connection between equations and curves were invented around 1640; the first real textbooks of differential and integral calculus were written already from around 1700. It is of course not quite true - but nearly - that in school one can only teach mathematics which is at least a couple of hundreds of years old. It would be desirable if mathematics was taught in a spirit that could tell the pupils something about what mathematics actually is in our time. This can only happen if teachers of mathematics are themselves acquainted with this spirit, and therefore they should know about non-Euclidean geometry.

References

The literature on non-Euclidean geometry and its history is of course enormous. On request, the author will be pleased to send a list of references, containing c. 40 titles.

HISTORY OF COMBINATORICS

Robin Wilson, The Open University, England

In his *Dissertatio de arte combinatoria*, Leibniz described combinatorics as the study of placing, ordering and choosing a number of objects. Several books on the subject appeared in the 18th and 19th centuries, and one of these (by Nicholson) defined the subject as 'a branch of mathematics which teaches us to ascertain and exhibit all the possible ways in which a given number of things may be associated and mixed together'. By the 20th century, designs were also included, and the subject is now taken to include the whole of finite or discrete mathematics.

Broadly speaking, combinatorial problems fit into one or more of the following categories:

- existence problems: does ... exist? is it possible to ...?
- construction problems: if ... exists, how can we construct it?
- enumeration problems: how many ... are there? can we list them all?
- optimization problems: if there are several ..., which is the best?

Much of this article is concerned with enumeration problems, although other types of problem will appear.

Extended versions of this article may be found in Biggs, Lloyd and Wilson [1] and Wilson and Lloyd [2]. Early work on combinatorics is discussed more fully in Biggs [3]. Further information on Renaissance combinatorics is given in Knobloch [4] and in Fauvel and Wilson [5]. A more detailed account of the history of graph theory is given in Biggs, Lloyd and Wilson [6], which includes extracts from several works mentioned here.

Permutations and combinations

There are four types of selection problem in which r objects are to be selected from a set of n objects:

- if the selections are ordered and repetition is allowed, then the number of possible choices is n^r ;
- if the selections are ordered without repetition (*permutations*), then the number of choices is

$$(n)_r = n(n-1) \dots (n-r+1);$$

- if the selections are unordered without repetition (*combinations*), then the number of choices is

$$\binom{n}{r} = \frac{n!}{r!(n-r)!}.$$

- if the selections are unordered with repetition, then the number of choices is

$$\binom{n+r-1}{r} = \frac{(n+r-1)!}{(n-1)!r!}.$$

Possibly the earliest example of ordered selections with repetition occurred in the 7th century BC *I Ching* (Book of changes), where the symbols for the yin and yang were combined into hexagrams (systems of six symbols) in $2^8 = 64$ ways.

There are also early examples from India. In a medical treatise of Susruta, there is a discussion of the combinations of tastes that can be made from the six basic qualities sweet, acid, saline, pungent, bitter and astringent. A systematic list is given of the combinations — there are six possibilities when taken separately, fifteen when taken in twos, twenty in threes, fifteen in fours, six in fives, and one when taken all together.

Other Hindu examples occur around 200 BC in the work of the Jainas, where there are discussions involving combinations of males, females and eunuchs, and in the writings of Pingala, concerning the metrical rhythms that can be constructed from a given number of short and long syllables. Later, in the sixth-century *Brhat Samhita* of Varahamihara, it is clearly stated that the number of ways of choosing four out of sixteen ingredients to make perfume is

$$\binom{16}{4} = 1820.$$

In the 11th century, Bhaskara's *Lilavati* asks for the number of variations of the god Sambhu by the exchange of the ten attributes held in his several hands — the rope, elephant's hook, serpent, tabor, skull, trident, bedstead, dagger, arrow and bow; the answer ($10!$) is correctly given as 3628800.

Much European interest in permutations and combinations arises from theological concerns — both Jewish and Christian. An 8th-century Jewish text *Sefer yetsirah* (Book of creation) calculates the number of ways of arranging the 22 letters of the Hebrew alphabet; this was of importance, because some combinations of letters had powers over nature. A later Jewish writer Rabbi ibn Ezra used combinations in an astrological context to calculate the number of possible conjunctions of the planets.

The 13th-century Catalan mystic Ramon Lull believed that all knowledge arises from a number of basic categories, and by moving through all possible combinations of these categories one can thereby discover everything. He used combinatorial diagrams to present the active manifestations of the divine attributes (goodness, power, etc.), and constructed models to demonstrate combinations of these. His work was taken up by many other Renaissance religious teachers, including Marin Mersenne (who used combinations in a musical context, and exhibited all factorials up to $64!$, a 90-digit number) and Athanasius Kircher (who exhibited all permutations of the letters in the words ORA, AMEN and PATER and a table of the 324 ordered pairs of the 18 attributes). Leibniz was also an enthusiast for Lull's work in his earlier years, and Lull's influence is clearly visible in the work mentioned at the beginning of this article.

The importance of combinations arises not only from their combinatorial interest, but also from their appearance as binomial coefficients. In particular, they appear in the well-known 'Pascal triangle'. Pascal discussed his triangle in his *Traite du triangle arithmetique*, but it had appeared many years earlier in Jordanus de Nemore's *De arithmetica* (c. 1225), al-Tusi's *Handbook of arithmetic using chalk and dust* (1265), and in a Chinese text of 1303. A full discussion of the triangle and its history appears in Edwards [7].

Partitions

A long-standing problem is to find the number $p(n)$ of ways of partitioning the positive integer n into positive integers; the order in which the numbers appear is irrelevant. For example, there are five partitions of the number 4—namely,

$$4, 3 + 1, 2 + 2, 2 + 1 + 1 \text{ and } 1 + 1 + 1 + 1$$

—and so $p(4) = 5$.

It is a simple matter to write down the values of $p(n)$ for small values of n ; for example,

$$p(1) = 1, p(2) = 2, p(3) = 3, p(4) = 5, p(5) = 7,$$

and so on, and a natural question is to ask for a general formula for $p(n)$. Similarly, one can ask for the number of partitions of a given number into odd parts, or even parts, or distinct parts.

In his *Introductio in analysin infinitorum* of 1748, Euler noted many theorems on partitions, including the following results:

- the number of partitions of n into odd parts is equal to the number of partitions into distinct parts;
- the number of partitions of n into odd parts is equal to the number of partitions into even parts, except when n is a number of the form $n(3n \pm 1)/2$, in which case these numbers differ by 1.

He also obtained his fundamental *partition-generation function*

$$1 + p(1)x + p(2)x^2 + p(3)x^3 + \dots = [(1-x)(1-x^2)(1-x^3) \dots]^{-1}$$

from which one can successively calculate $p(1), p(2), p(3), \dots$.

The values of $p(n)$ increase very rapidly with n . Euler calculated the values of $p(n)$ up to $n = 69$, and in the 1890s Percy MacMahon constructed a table up to $p(200) = 3972999029388$, but these results pale into insignificance in comparison with a 1918 paper of Hardy and Ramanujan. In this truly remarkable paper, the authors obtained an almost unbelievable formula for $p(n)$ as the nearest integer to an expression involving square roots, derivatives, exponentials and $24q$ -th roots of unity. Studying MacMahon's table of values, Ramanujan was able to prove several other results, such as

$$p(5n+4) \text{ is divisible by } 5, \text{ and } p(7n+5) \text{ is divisible by } 7.$$

Graph theory

The subject of graph theory originated with Leonhard Euler's 1735 presentation of the Königsberg bridges problem, in which four land areas are connected by seven bridges and it is required to find a route that crosses each of these bridges just once. Euler proved that there can be no such route, and showed how his method can be extended to any arrangement of islands and bridges. Although his approach was essentially graph-theoretic, he did not use graphs as such, and the four-vertex graph

usually drawn to represent the problem did not appear until the end of the 19th century when Rouse Ball included the problem in his book on recreational mathematics.

Another type of traversal problem was discussed by Sir William Rowan Hamilton, whose studies on non-commutative algebras led him to consider cycles on a dodecahedron passing just once through each vertex. Problems of this type had already been discussed by the Rev. Thomas Kirkman, who investigated which polyhedra have such a cycle. Unlike the Eulerian problem, which has a simple solution, traversal problems of this kind are hard to solve.

It was known in the 19th century that certain graphs cannot be embedded without crossings in the plane. For example, August Möbius observed that one cannot draw five mutually adjacent regions in a plane, and one can easily deduce that it is impossible to embed in the plane the complete graph K_5 in which each of five points is joined to each of the other four. Another graph that cannot be embedded in the plane is the complete bipartite graph $K_{3,3}$ consisting of three non-adjacent points all joined to three other non-adjacent points; this problem has been known for many years as the *gas-water-electricity problem*, although its exact origins are unknown.

The most famous problem in graph theory is the four colour problem, which asks whether every map can be coloured with just four colours in such a way that neighbouring countries are differently coloured. This problem, due to Francis Guthrie in 1852, was communicated to Augustus De Morgan, who in turn communicated it to other mathematicians. In 1879, Alfred Kempe proved that every map can indeed be so coloured, but his proof was later found to be fallacious by Percy Heawood (1890), and a correct proof was not produced until 1976 when Kenneth Appel and Wolfgang Haken produced an argument that involved the detailed analysis of almost 2000 different configurations of countries and hundreds of hours of computer time. Heawood also gave a formula for the number of colours needed for maps on surfaces other than the plane or sphere, but his proof was deficient and the gap was not filled until 1968 by Gerhard Ringel and Ted Youngs.

Counting with symmetry

Particularly important among graph problems are those involving trees — connected graphs with no cycles. Their mathematical study dates from the 19th century, and although they originally arose in connection with a problem in the differential calculus, they also arise naturally in chemistry, where isomer-counting problems frequently reduce to those of counting trees with certain properties. In particular, mathematicians and chemists became interested in enumerating alkanes (paraffins) with formula $C_n H_{2n+2}$, for a given number n of carbon atoms; this problem was solved in the 1870s by Arthur Cayley using techniques devised by himself, J.J. Sylvester and Camille Jordan.

In any enumeration problem of this kind, it is important to decide exactly when two structures are to be considered different. For example, two different structures can become the same if one is rotated or reflected into the other, and it is necessary to formulate the appropriate enumeration problem carefully. Cauchy and Frobenius expressed the number of essentially different structures in a formula often erroneously called *Burnside's lemma*. A refinement of these ideas led to more general

enumeration problems involving symmetry, and the key ideas to solving such problems were presented independently in the 1920s and 1930s by Howard Redfield and Georg Polya, and is now known as *Polya's theorem*.

Designs

In 1835 the geometer Julius Plücker observed that a system $S(n)$ of n symbols, arranged into triples in such a way that any two points lie in just one triple, is possible only when $n = 1$ or $3 \pmod{6}$. In 1847, Kirkman showed how to construct such a system $S(n)$ for any number n of this form, and described a system $S(15)$ with 35 triples partitioned into seven sets of 5 triples in such a way that each symbol occurs just once in each set of 5; this system gives a solution of the *Kirkman schoolgirls problem* (1850) in which 'fifteen young ladies in a school walk out three abreast for seven days in succession; it is required to arrange them daily, so that no two shall walk twice abreast'. The system $S(n)$ is now known as a *Steiner triple system*, after Jakob Steiner who studied them in 1853, several years after Kirkman had done so. In 1971, D.K. Ray-Chaudhuri and R.M. Wilson proved that there is a Steiner triple system $S(n)$ that can be partitioned as in Kirkman's schoolgirls problem whenever $n = 3 \pmod{6}$.

Kirkman also constructed geometric systems with r^2+r+1 points and r^2+r+1 lines, with $r+1$ points on each line and $r+1$ lines passing through each point, where r is a prime number or 4 or 8; these systems are now known as *finite projective planes* of order r , and are known to exist whenever r is a power of a prime number. In 1900 Gaston Tarry proved that there is no finite projective plane of order 6, and after a long computer search in the 1980s, Clement Lam proved the non-existence of a projective plane of order 10. It is not known whether there exists a projective plane of order r for any other composite value of r .

Much of the recent interest in such systems arises from the design of agricultural experiments in which a field may need to be planted with varieties of wheat that are to be compared in pairs. Pioneering work in this area was carried out in the 1930s by Ronald Fisher and Frank Yates, and led to the general study of balanced incomplete block designs; these have been extensively investigated in the past few years.

References

1. N.L. Biggs, E.K. Lloyd and R.J. Wilson, The history of combinatorics, *Handbook of combinatorics* (ed. R. Graham et al.), Elsevier Science B.V., 1995.
2. R.J. Wilson and E.K. Lloyd, Combinatorics, *Companion encyclopaedia of the history and philosophy of mathematics* (ed. I. Grattan-Guinness), Routledge, 1993.
3. N.L. Biggs, The roots of combinatorics, *Historia mathematica* **6** (1979), 109-136.
4. E. Knobloch, Musurgia universalis: Unknown combinatorial studies in the age of Baroque absolutism, *History of science* **17** (1979), 258-275.

5. J. Fauvel and R.J. Wilson, The Lull before the storm: combinatorics and religion in the Renaissance, *Bull. Inst. Comb. Appl.* **11** (1994), 49-58.
6. N.L. Biggs, E.K. Lloyd and R.J. Wilson, *Graph theory 1736-1936*, Clarendon Press, Oxford, 1986.
7. A.W.F. Edwards, *Pascal's arithmetical triangle*, Griffin, 1987.

PROBLEM SOLVING FROM THE HISTORY OF MATHEMATICS

Frank J. Swetz

Teachers have always labored to find good problems for their students, that is, problems whose solutions require the application of certain mathematical concepts and techniques whose contents demand a certain amount of interpretation and whose presentation can capture and hold the interest of a student. A really good problem is one that possesses all these qualities and furthermore gives rise to other problems; it is a stimulus for mathematical exploration and classroom discussions. Such problems can be found in the realities of daily life, the demands of the workplace and in universal issues of popular concern: the population explosion, pollution, inflation, and so on. But while contemporary relevance can supply a focus for problem-solving activities, historical excursions based on problems devised by our forebears also enliven and enrich classroom presentations.

Since earliest times, written records of mathematical instruction have almost always included problems for the reader to solve. Mathematics instruction was certainly considered an activity for self-involvement. The luxury of a written discourse and speculation on the theory of mathematics appeared fairly late in the historical period with the rise of Greek science. Prior records from older civilizations, namely those of Babylonia, Egypt and China, reveal that mathematics instruction was usually incorporated into a list of problems whose solution scheme was then given. Quite simply, the earliest known mathematics instruction concerned problem solving. Obviously, such problems, as the primary source of instruction, were carefully chosen by their authors both to be useful and to demonstrate the state of their mathematical art. The utility of these problems was based on the immediate needs of the societies in question and thus reflect aspects of daily life seldom recognized in formal history books. Such collections of problems are not limited to ancient societies but have appeared regularly throughout the history of mathematics up until the present time.

In this literature of mathematics, thousands of problems have been amassed and await as a ready reservoir for classroom exercises and assignments. The use of actual historical problems not only helps to demonstrate problem solving strategies and sharpen mathematical skills, but also:

imparts a sense of the continuity of mathematical concerns over the ages as the same problem or type of problem can be found in different societies at diverse periods of time;

illustrates the evolution of solution processes -- the way we solve a problem may well be worth comparing with the original solution process, and

supplies historical and cultural insights of the peoples and times involved.

A Survey of Historical Problems, Some General Impressions

In the examination of old mathematical problems, a continuity of attention to right triangle theory is most evident:

A reed stands against a wall. If it moves down 9 feet (at the top), the (lower) end slides away 27 feet. How long is the reed? How high is the wall? (Babylonia, 1600-1800 B.C.)

An erect (vertical) pole of 30 feet has its base moved out 18 feet. Determine the new height and the distance the top of the pole is lowered. (Egypt, 300 B.C.)

A spear 20 feet long rests against a tower. If its end is moved out 12 feet, how far up the tower does the spear reach? (Italy, A.D. 1300)

A bamboo shoot 10 feet tall has a break near the top. The configuration of the main shoot and its broken portion forms a triangle. The top touches the ground 3 feet from the stem. What is the length of the stem left standing erect? (China, 300 B.C.)

While these are simple applications of the "Pythagorean" theorem, more complex and imaginative situations were also considered:

A tree of height 20 feet has a circumference of 3 feet. There is a vine which winds seven times around the tree and reaches the top. What is the length of the vine? (China, 300 B.C.)

(Given a vertical pole of height 12 feet.) The ingenious man who can compute the length of the pole's shadows, the difference of which is known to be nineteen feet, and the difference of the hypotenuses formed, 13 feet, I take to be thoroughly acquainted with the whole of algebra as well as arithmetic. (India, 1000 A.D.)

Problem similarities are not only limited to mathematical contexts. Societal concerns also allow for comparisons. Early societies concern with food, particularly grain is evident from the context of many problems:

Suppose a scribe says to thee, four overseers have drawn 100 great baskets of grain, their gangs consisting, respectively, of 12, 8, 6 and 4 men. How much does each overseer receive? (Egypt, 1600 B.C.)

The yield of 3 sheaves of superior grain, 2 sheaves of medium grain, and 1 sheaf of inferior grain is 39 baskets. The yield (from another field) of 2 sheaves of superior grain, 3 sheaves of medium grain, and 1 sheaf of inferior grain is 34 baskets. (From a third field) the yield of 1 sheaf of superior grain, 2 sheaves of medium grain, and 3 sheaves of inferior grain is 26 baskets. What is the yield of superior, medium, and inferior grains? (China, 300 B.C.)

From a certain field, I harvest 4 wagons of grain per unit of area. From a second field, I harvest 3 units of grain per unit area. The yield of the first field was 50 wagons more than that of the second. The areas of both fields is known to be 30 units. How large is each field? (Babylonia, 1500 B.C.)

Early society's concern with grain, its harvesting, storage and distribution reflects their agricultural status. One chapter of the famous Chinese mathematical classic *Jiuzhang suanshu* (300 B.C. - 200 A.D.) is entitled millet and rices -- it concerns the use of proportions in the distribution of these grains. Throughout the ages, the division and pricing of foodstuffs has provided the basis for many problems.

There were two men, of whom the first had 3 small loaves of bread and the other 2; they walked to a spring, where they sat down and ate. A soldier joined them and shared their meal, each of the three men eating the same amount. When all the bread was eaten the soldier departed, leaving 5 bezants to pay for his meal. The first man accepted 3 of the bezants, since he had three loaves; the other took the remaining 2 bezants for his 2 loaves. Was the division fair? (Italy, 1202).

Even the size of a loaf of bread from 15th century Venice can be deduced from a problems contents:

When a bushel of wheat is worth 8 lire, the bakers make a loaf weighing 6 ounces; required the number of ounces in the weight of a loaf when a bushel is worth 5 lire.

Insights into the use and rewards for labor can be found in problems:

It is known that the digging of a canal becomes more difficult the deeper one goes. In order to compensate for this fact, differential work allotments were computed: a laborer working at the top level was expected to remove $\frac{1}{3}$ sar of earth in one day, while a laborer at the middle level removed $\frac{1}{6}$ sar and at the bottom level, $\frac{1}{9}$ sar. If a fixed amount of earth is to be removed from a canal in one day, how much digging time should be spent at each level? (Babylonia, 1500 B.C.)

Warner receives \$2.50 a day for his labor and pays \$.50 a day for his board; at the finish of 40 days, he has saved \$50. How many days did he work and how many days was he idle? (United States, 1873).

Compensation for work performed reveal social injustices and societal inequities:

If 100 bushels of corn be distributed among 100 people in such a manner that each man receives 3 bushel, each woman 2, and each child $\frac{1}{2}$ bushel, how many men, women and children were there? (England, 800 A.D.)

If 20 man, 40 women and 50 children receive £ 350 for seven weeks work, and 2 men receive as much as 3 women or 5 children, what sum does a woman receive for a week's work? (England, 1880)

In a 1000 years, has the status of a woman's labor improved?

Alcuin of York compiling problems in about the year 800, notes the need for military conscription:

A king recruiting his army, conscripts 1 man in the first town, 2 in the second, 4 in the third, 8 in the fourth, and so on until he has taken men from 30 towns. How many men does he collect in all?

Apparently in Victorian England the practice was still taking place, although at a less dramatic level.

The number of disposable seamen at Portsmouth is 800; at Plymouth 756; and at Sheerness 404. A ship is commissioned whose complement is 490 seamen. How many must be drafted from each place so as to take an equal proportion? Hamblin's Treatise of Arithmetic (1880).

Geometric situations also provided the setting for problems:

A circular field of land can contain an equilateral triangle of side 36 feet. What is the size of the field? (Egypt, 300 B.C.)

Given a right triangle with legs 8 and 15 feet, respectively. What is the largest circle that can be inscribed in this triangle? (China, 300 B.C.)

The radius of an inscribed circle of a triangle is 4, and the segments into which one side is divided by a point of contact are 6 and 8. Determine the length of the two remaining sides of the triangle. (Renaissance Europe).

As mathematical knowledge became more sophisticated, the computational demands of problems increased. Girolamo Cardano in his Ars Magna (1545) challenged his readers to solve cubic equations through the use of problems such as the following:

An oracle ordered a prince to build a sacred building whose space would be 400 cubits, the length being 6 cubits more than the width, and the width 3 cubits more than the height. Find the dimensions of the building.

Problems as a Mathematical Testament

While problems can supply much information about the societies and times in question, they also illustrate the mathematical needs and ingenuity of our ancestors. From examining a problem's contents, students are often amazed to discover that before the Christian era, people were solving systems of linear equations and applying iterative algorithms to compute square and cube roots of numbers to a good degree of accuracy. At various periods of history certain problems denote the mathematical environment. While ancient Chinese and Egyptian mathematics focused on utilitarian needs, Greek mathematicians were busy with such non-utilitarian concerns as:

1. The duplication of the cube
2. The trisection of an angle
3. The quadrature of the circle

These problems were to be solved with the use of a straightedge and compass alone. It was over two thousand years before this feat was proved impossible, but yet, in the interim search for solutions, many useful mathematical discoveries were made, including a theory of conic sections and the development of cubic, quadratic, and transcendental curves. Out of this particular legacy emerged a series of geometric problems that can challenge and fascinate modern students. In the search to achieve a quadrature of the circle, a theory of lunes developed and problems like those that follow resulted.

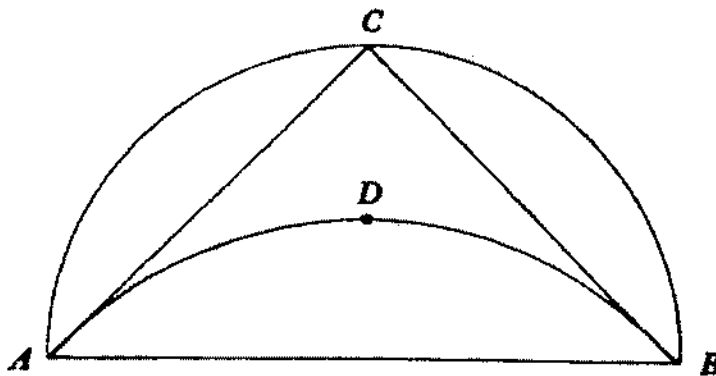

Given a semicircle with diameter AB , arc ADB is inscribed in the semicircle. The region bounded between the semicircle and the arc is called a lune. Show that the area of the lune $ACBD$ is equal to the area of the inscribed triangle ACB where $\overline{AC} \cong \overline{CB}$.

Problems become more complex and further removed from reality, as shown by a consideration of the arbelos and its properties

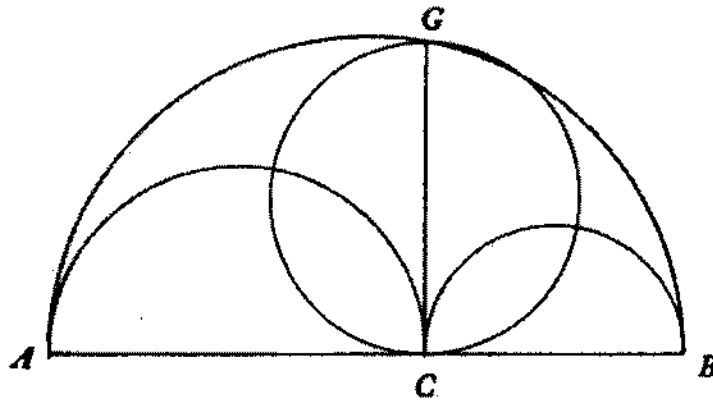

Let A, C, and B be three points on a straight line. Construct semicircles on the same side of the line with AB, AC, and CB as diameters. The region bounded by these three semicircles is called an *arbelos*. At C construct a perpendicular line to AB intersecting the largest semicircle at point G. Show that the area of the circle constructed with CG as a diameter equals the area of the arbelos.

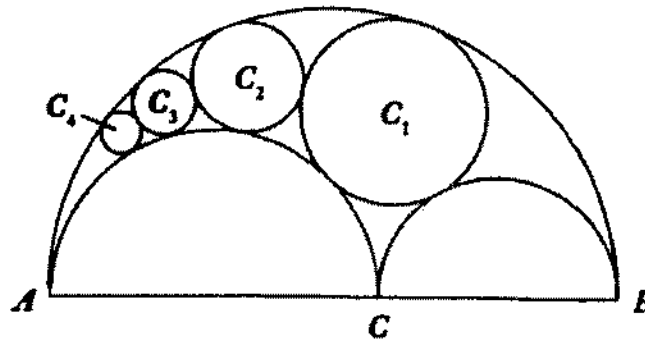

Given an arbelos packed with circles C_1, C_2, C_3, \dots , as indicated, show that the perpendicular distance from the center of the n th circle to the line ACB is n times the diameter of the n th circle.

It was well into the nineteenth century before the three classical Greek problems were shown to be unsolvable by construction but their legacy has left us with much interesting mathematics.

Collections of mathematical problems often yield riddle or puzzle situations that seem to be pure intellectual exercises. Perhaps the most famous of such problems concern a goat, a wolf and a cabbage:

A wolf, a goat and a cabbage must be transported across a river in a boat holding only one besides the ferryman. How must he carry them across so that the goat shall not eat the cabbage, nor the wolf the goat? (Alcuin, 800 A.D.)

Such problems still fascinate and amuse students.

Conclusion

The history of mathematics contains a wealth of material that can be used to inform and instruct in today's classrooms. Among this material are historical problems and problem solving situations. While historical problem solving can be a focus of a lesson, it is probably a better pedagogical practice to disperse such problems throughout the instructional process. Teachers who like to assign a "problem of the week" will find that historical problems nicely suit the task. Ample supplies of historical problems can be found in old mathematics books and in many survey books on the history of mathematics. These problems let us touch the past but they also enhance the present. Questions originating hundreds or even thousand of years ago can be understood and answered in today's classrooms. What a dramatic realization that is!

COMPUTATIONAL DEVICES IN HISTORY

John Fauvel, The Open University, UK

Last month the European space programme suffered an enormous set-back. The great space rocket Ariane 5 started going in the wrong direction just after take-off and had to be blown up, scattering half a billion pounds-worth of investment over the jungles of Guiana. What went wrong? The problem, we are told by the “experts”, lay in the computers; in particular, in the software. The rocket went off course not because the the hard technology was at fault (as was the case with the Challenger disaster in the United States, for example) but because the computer software was feeding wrong instructions through to the rockets. *“Something went wrong with the electronic brain which sent the wrong command to the booster engines”*, as one of the investigators explained. At one level this explanation sounds rather like the excuse when you receive a final electricity demand for 0 escudos: it is blamed on “the computer”, when you know that the computer has in fact done exactly what it was programmed to do. At another level, though, we may reflect on the Ariane calamity as a microcosm of the role of computational devices in today’s society, and the delicate train of human and electronic and technological events which carry a heavy social meaning and significance.

In the same week as the electronic brain went wrong, I noticed another symbol of human relations with computers and technology in my daily newspaper, in a full-page advertisement of a computer company, the Digital Equipment Corporation. Under a photograph of three children making some adjustments to a bicycle, the text reads, in part,

The principles we’re building the future of computing around weren’t all learned at university. Long before we learned the first thing about building computers, some fundamentals equally crucial to information technology took root in our little heads: Like, co-operating. Sharing. Working with others. [. . .] In short, together we’re building something no one could construct alone. It’s called, a future.

The warm glow that this advertisement creates seems designed to humanise the world of computational technology, and to help restore the balance in an area that has often been represented as inhuman and soul-less, even when not giving the wrong instructions to rocket engines. In recent months and years, indeed centuries, the inhumanity of science and technology has been a recurrent theme of cultural criticism, from the Prometheus myth all the way to the Unabomber. This critique has often focussed on computational devices and on any apparent handing over of human judgement to mechanical devices.

Let me give you another example. In 1823 Charles Babbage sought funding from the British government for the construction of the Difference Engine that he planned would calculate accurate logarithm tables mechanically—calculate by steam, as he put it in the moment of inspiration. To

check on the functioning of this computational engine he used the test formula $x^2 + x + 41$, a famous formula because of its use by Euler to generate a very long run of prime numbers (right up to $x = 40$, in fact). The British Home Secretary at the time was Robert Peel, who turned the proposal down, explaining in a letter to a friend

"Aut haec in nostros fabricata est machina muros, aut aliquis latet error." I should like a little previous consideration before I move in a thin house of country gentlemen, a large vote for the creation of a wooden man to calculate tables from the formula $x^2 + x + 41$.

[Robert Peel to J. W. Croker, 8 March 1823, cited Hyman p.52]

This is an interesting and illuminating text. The Latin quotation is from the second book of the *Aeneid* of Virgil, the Roman poet of the 1st century BC, and means something like *"Either it is an engine designed against our walls or some other mischief lies in it"*. This refers of course to the Trojan horse, which has long stood as a metaphor for treacherous enemy incursion, and betrayal from within. This kind of rhetoric using quotations from Greek or Latin poetry was characteristic of the period, but it captures his meaning very exactly, perhaps better than he knew. Peel was a highly educated man; he was indeed the first 'double first' at Oxford, that is, placed in the first class in both classics and mathematics in 1808. Nonetheless, he could not or chose not to see the advantages of public support for Mr Babbage's engine, using as his argument the incomprehension of members of parliament about the point of a formula for generating prime numbers

In fact if Peel or the House of Commons had known a little more history they need not have been so surprised. Since the dawn of time a variety of material models have been used to help in the process of calculation, and in presenting the results. Sometimes, indeed, such material models determine and further influence how computations can be carried out, and lead to further conceptual advances in how people think and see mathematically. Nowadays we are in a good position to help young people do better than Peel, and understand that, historically, one of the characteristics of being human has been using material computational models. Indeed, the long human quest for calculation and for registering the results of mathematical activity has been pursued since the dawn of time, and for long has been one of the most sophisticated forms of human activity, often at the forefront of technological developments.

The earliest mathematical modelling we know of was concerned with time: perhaps that in which the lunar cycle was modelled by notches on a baboon bone, or where the passage of time has been modelled by recording solar movements, through the shadows cast by a gnomon of a sundial. Soon, the cosmos itself was to be modelled by an astrolabe, an astronomical instrument of great beauty and considerable mathematical power. There is a lot of interesting material here that can be explored in a school context.

But I want to explore an even more basic level, and look at the foundations of our written number system. Numerals themselves may be

thought of as a modelling device, that is, as representations of the results of human activity in a (generally) simpler way for a specific purpose. If this idea seems a bit strange at first, I ask you to consider the quipu, say. This Peruvian way of recording numbers enabled them to be carried for long distances, or put in archives, so that the results of economic activity and other statistical information could be represented in string, modelled by knots on a cord. In ancient Mesopotamia, a system of written numerals was evolved, as a way of modelling numbers in clay marks. Recent research, notably that of Denise Schmandt-Besserat, shows that writing itself developed out of activities of mathematical modelling in a commercial and administrative setting. Mathematical modelling is historically prior, antecedent to, the development of writing. This is a striking result which should give a morale boost to the mathematics teacher. Of the traditional “three Rs”—reading, writing and arithmetic—it is arithmetic which is the basic foundational one.

From the computational point of view, the Hindu-Arabic numerals were a major development because they form a system in which both computation and the registering of numerical results could be carried out quite efficiently. Hitherto, numerals tended to be for registering the results of a computation carried out on something else, whether a counting-board or abacus, or indeed a computer like an astrolabe. The algorithmic quality of Hindu-Arabic numerals, the fact that you can devise fairly straightforward procedures for doing calculations with the numerals themselves, was a major factor in their success.

In the dialectic between computational methods and material devices, the Hindu-Arabic numerals themselves fed back into computational devices. A good example of pen-and-paper computation passing closely into the technology of a harder material is the relation between Napier’s bones and the ancient gelosia or lattice multiplication technique from which it derives. At the beginning of the seventeenth century, the Scottish laird John Napier devised a system of multiplying using small strips or blocks, made of wood or bone, which can be seen to reproduce, in material, precisely the mediaeval Italian way of doing the same computation in which you drew it on paper, stemming in turn from the decimal place-value nature of Hindu-Arabic numerals.

It was another of Napier’s inventions, *logarithms*, which led ultimately, through the interplay between concepts and technologies over a long period, into modern universal calculating devices. Within a few years they formed the basis for a material model, the *slide rule*, but it was in table form that they were of most utility for precision calculations in navigation and elsewhere. The consequences of inaccurate logarithm tables could be fatal, and it was to overcome this problem that Charles Babbage worked on the mechanical computation of logarithm tables, using the *method of differences*—hence the name of his machine, the *difference engine* which I mentioned earlier. A principle of the mechanisation of calculation is to repeat basic arithmetical steps a large number of times. On the TV programme I’ll play you shortly, this process (which was envisioned in Adam Smith’s description of manufacturing techniques) is modelled by school-children in their school hall.

With another machine he designed, the Analytic Engine, Babbage developed the remarkable conception of a programmable computing machine with conditional pathing (that is, a calculation done by the machine, or a path the programme follows, could be dependent on the result of an earlier calculation). This machine was never built, for various reasons, but the similarity with the system design of modern computers is remarkable. In fact there seems little direct connection from Babbage's Analytic Engine to the modern computer, and the detailed design of Babbage's work has only become rediscovered in recent years.

In some ways the high point of Victorian mechanical computation is not a digital machine at all but an analogue one, that is, modelling a process by a device showing analogous behaviour. Lord Kelvin's *tide predictor* is a superb tribute to Victorian mathematical modelling skills and brass technology, and we'll see this on the TV programme also.

The main message I want to leave you with, from this very rapid survey of computation through the ages, is the way that computational concepts and methods and technology all nourish each other. In our own day we see that developments in mathematics lead to advances in computer hardware and software which in turn make possible new mathematics. Whole new areas of mathematics have blossomed—chaos theory and fractals are obvious cases in point—which could not really be envisioned without the computer. Yet in equipping young people for the world they will face, we can hardly do better than go back to the beginning and explore with them the basic principles, which are still true and relevant, of algorithms and computational processes which will give them a solid basis for their development.

Some further reading

Ishango Bone

Alexander Marshack, *The roots of civilisation*, Weidenfeld & Nicolson 1972

Babylonian mathematics

Denise Schmandt-Besserat, *Before writing: from counting to cuneiform*, University of Texas Press 1992

Georges Ifrah, *From one to zero: a universal history of numbers*, Penguin 1987. ISBN 0 1400 9919 0

Quipus

Marcia Ascher, *Ethnomathematics: a multicultural view of mathematical ideas*, Brooks/Cole 1991. ISBN 0-534-14880-8

Tally sticks

Karl Menninger, *Number words and number symbols: a cultural history of numbers*, MIT Press 1969. ISBN 0-262-13040-0

Babbage's Difference Engine

Doron Swade, *Charles Babbage and his calculating engines*, Science Museum 1991. ISBN 0 901805 45 9

MATHÉMATIQUES ET NAVIGATION: LE TRAITÉ DE PIERRE BOUGUER DE 1753

Xavier Lefort, IREM Pays de Loire, France

Il est certain qu'on ne nous instruit jamais mieux
ni plus aisément que lorsqu'on nous fait au moins
entrevoir les raisons des choses qu'on nous explique.
(Préface page VIII)

Sans doute de nouvelles méthodes ont pu reléguer au second plan les techniques traditionnelles de navigation, mais celles-ci sont toujours enseignées, et, si le satellite semble avoir détrôné le sextant, son maniement est toujours au programme des écoles de marine. Les supports mathématiques sont souvent très élaborés, mais il arrive qu'ils soient aussi suffisamment simples pour être utilisés dans nos enseignements.

En particulier les navigateurs du XVIII^{ème} siècle usaient de certaines techniques dont l'exposé ferait entrer dans nos cours non seulement le souffle de l'histoire, mais aussi celui de la haute mer! Cette époque est également celle de la transition entre des techniques artisanales et des méthodes plus scientifiques, et son aspect de charnière n'est pas le dernier de ses intérêts.

Bouguer

PIERRE BOUGUER est né au Croisic le 10 février 1698. Ce port était à cette époque l'un des plus grands centres européens pour le trafic du sel. Son importance avait conduit à y fonder une école d'hydrographie, c'est-à-dire une école de navigation ou exerçait JEAN BOUGUER, le père de notre auteur. Cette filiation conduisit rapidement ce dernier vers des études scientifiques dans lesquelles il se montra suffisamment brillant pour briguer la succession de son père, à la mort de celui-ci, en 1714. Malgré sa jeunesse, sa candidature fut agréée et le nouveau maître se rendit rapidement célèbre.

Ses travaux personnels le firent également connaître de l'Académie Royale des Sciences qui le récompensa en 1727 pour un ouvrage sur la mâture des navires, avant de le nommer en 1730 hydrographe royal au Havre. L'année suivante, il entra dans les rangs de l'Académie, et produisit nombre d'ouvrages relatifs à la navigation.

En 1735, PIERRE BOUGUER était envoyé au Pérou avec GODIN et LA CONDAMINE, pour mesurer à l'équateur la longueur d'un degré de méridien. Une polémique était en effet née entre



Pierre BOUGUER

l'Académie Royale des Sciences et son équivalente anglaise sur la forme de la terre. Les travaux de NEWTON conduisaient à concevoir la terre comme aplatie aux pôles, alors que les mesures effectuées par CASSINI pour dresser la carte de France à l'échelle pouvaient laisser croire qu'elle était allongée aux pôles. Deux expéditions étaient alors envoyées par l'Académie, l'une en Laponie, l'autre au Pérou, pour comparer les mesures de degré de méridien.

Cette dernière expédition dura dix ans et démontra la justesse de la théorie newtonienne. Mais elle fut aussi une véritable aventure, marquée, par les difficultés liées à la géographie, et par les discussions d'amour-propre entre les participants. Il s'agit également d'un des points de départ de l'application des mathématiques à la navigation.

De retour en France, BOUGUER ne récolta pas la gloire escomptée devancé par LA COMDAMINE, plus à l'aise dans la relation de leur voyage. Devenu sensible à l'excès, il ne se consacra plus qu'à des travaux théoriques. Le "Nouveau traité de navigation" est l'un de ceux-ci, paru en 1753.

Il faut aussi noter, entre autre, que BOUGUER est considéré comme l'inventeur de la photométrie, auteur d'un ouvrage posthume, "Traité d'optique sur la gradation de la lumière" qui est le premier du genre. N'ayant pas retrouvé sa santé après le voyage au Pérou, aigri et reclus, BOUGUER mourut le 15 août 1758.

Le Traité

La Géométrie

JEAN BOUGUER avait fait paraître en 1698 un premier traité de navigation, réédité dès 1706. Les techniques et les instruments évoluant, son fils préféra un nouvel ouvrage plutôt qu'une réédition actualisée. Par ailleurs le besoin d'un tel livre se faisait sentir, au point de répondre à une commande ministérielle:

" Je satisfais par la publication de cet ouvrage à un engagement que j'avais contracté il y a quelques années, et je remplis en même temps des ordres supérieurs auxquels j'ai dû me conformer avec empressement. Mr ROUILLE ayant considéré que dans l'art de naviguer, la théorie devrait éclairer continuellement la pratique, et que d'un autre côté la pratique ne devait rien emprunter inutilement de la théorie, me fit l'honneur de me demander un traité de pilotage sur ce plan. J'ai travaillé à exécuter ces ordres, et je n'ai fait autre chose dans cet ouvrage, que tâcher de me conformer aux vues éclairées d'un Ministre, qui continuellement occupé du soin de procurer de nouveaux progrès à la marine, protège toutes les sciences qui y ont rapport." (Préface page V)

L'ouvrage est divisé en cinq "livres", dont le premier est consacré aux "premières connaissances de géométrie qui sont nécessaires aux pilotes". Ce n'est pas un exposé théorique, mais essentiellement pratique, sans démonstrations. Les notions euclidiennes sont survolées pour laisser place à des techniques et à des exemples concrets. La résolution des triangles prend une place importante, et la formule fondamentale selon laquelle, dans un triangle, le rapport du sinus d'un angle au côté opposé est constant est énoncée. Elle est illustrée par l'exemple suivant issu des travaux de l'Abbé PICARD, lorsque COLBERT l'avait chargé de lever les côtes de France:

“Nous rapporterons ici l’opération par laquelle Mr PICARD et DE LA HIRE déterminèrent la largeur du Pas-de-Calais, qui est l’endroit le plus étroit de la Manche, ou du canal qui sépare la France de l’Angleterre. Ils mesurèrent sur la grève, en commençant à la pointe du Bastion du Risban de Calais une base CB de 2510 toises de longueur. Ils prirent ensuite avec un instrument exact la mesure des angles C et B, en visant des deux points de station, au milieu des deux tours les plus apparentes du château de Douvres. Ils trouvèrent l’angle en C de $37^{\circ}58'$, l’angle en B de $137^{\circ}30'$. Ainsi l’angle à Douvres qui est le reste à 180° , puisque les trois d’un triangle forment toujours le demi-cercle était de $4^{\circ}32'$, et c’est donc la valeur de l’angle D. Cela supposé, il ne reste plus qu’à chercher dans les tables les sinus des angles B et D et à former cette analogie ou règle de trois: le sinus de l’angle D est au coté opposé CB ou à la base mesurée, comme le sinus de l’angle B est au coté CD, qui est celui qu’on voulait découvrir.” (21369 toises)

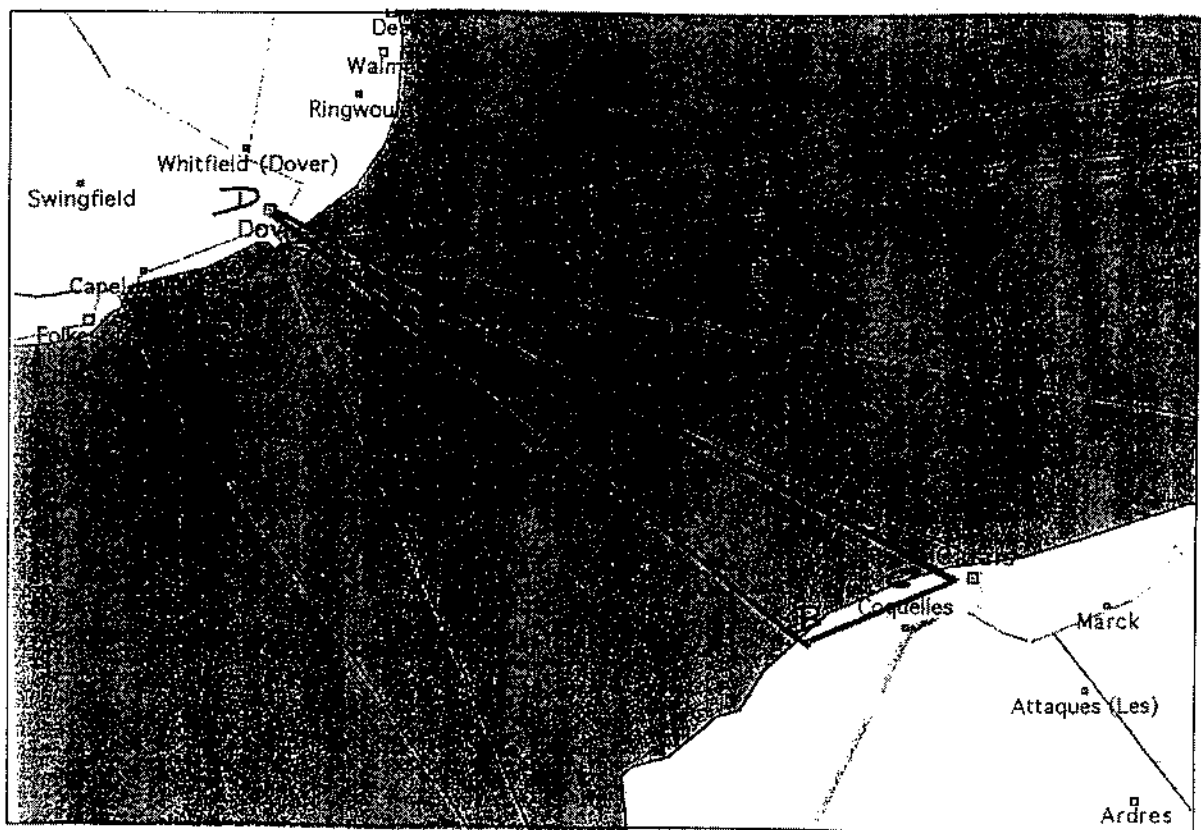

Pour terminer ce premier livre, BOUGUER indique qu’il est plus aisé pour les calculs, d’utiliser les logarithmes, mais, bien sur, sans les présenter de manière théorique. Il traite le problème précédent comme exemple, en utilisant une table de logarithmes, incluant es logarithmes des sinus, table se trouvant en annexe de ce premier livre.

Figure de la Terre

Il n’est pas étonnant de constater que BOUGUER accorde une large place au problème de la forme de la terre. Non seulement cette question a occupé une importante partie de sa vie, puisqu’il a été envoyé au Pérou pour mesurer le degré de méridien, mais aussi,

bien entendu, parce qu'il s'agit également de représenter la terre c'est-à-dire de traiter du problème des cartes. Le second livre commence par l'exposé des notions élémentaires de repérage terrestre: pôles, tropiques, latitude, longitude. La boussole, sa construction comme son utilisation occupe le second chapitre. Cet instrument étant de première importance, l'auteur s'y attarde, d'autant que les directions indiquées par la boussole sont évidemment les routes suivies par les navires, et correspondent aux loxodromies, en langage mathématique. Une telle direction est appelée "rumb de vent". On aurait pu attendre une théorie, même succincte, de la représentation de la terre; BOUGUER en décrit la difficulté, et si les inconvénients des cartes plates sont mis en évidence, il n'y a pas dans l'ouvrage de justification mathématique, tout au plus une indication des corrections à effectuer dans certaines situations.

Le livre III est consacré aux "premières notions d'astronomie qui sont utiles aux navigateurs". Cette partie est deux fois plus courte que la précédente, et ne contient que quelques descriptions élémentaires. L'essentiel consiste en la reconnaissance des étoiles fixes, nécessaires pour faire le point en mer, ainsi que des considérations sur les années bissextiles et sur le mouvement de la lune.

Les Instruments

Les deux derniers livres de l'ouvrage de BOUGUER sont consacrés aux "usages qu'ont dans la navigation les différentes connaissances (...) données dans le chapitre précédent", plus précisément, il s'agit de se situer sur la surface de la terre, de déterminer la route à suivre et de la reporter correctement sur une carte.

Pour se situer, pour faire le point, l'auteur donne les moyens de trouver latitude et longitude. Il indique l'utilisation de la position des astres pour résoudre le problème, et explique la construction et l'usage des instruments de l'époque. Certains, comme l'arbalétrille sont pourtant dépassés techniquement, mais leur conception relativement simple en permet la description et l'usage sans faire beaucoup appel à la théorie.

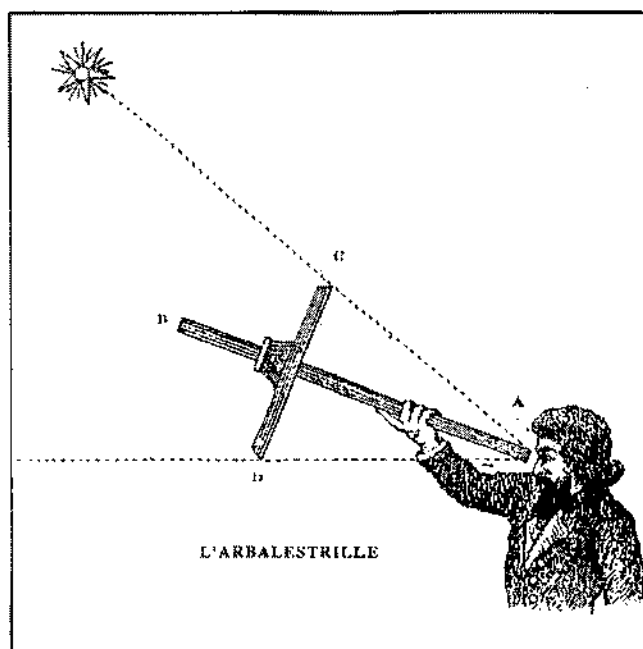

En 1731 HADLEY avait présenté à la Royal Society un nouvel instrument appelé "octant", puisque les mesures étaient effectuées sur un huitième de cercle. Cet instrument est donc construit autour d'un secteur circulaire balayé par un alidade fixé au centre du secteur. Sur ce centre, solidaire de l'alidade, est fixé un petit miroir. Deux "pinnules", c'est-à-dire deux petites ouvertures, sont fixées sur les cotés du secteur, à égale distance du centre, et permettent par visée de régler l'horizontalité de l'appareil. Une de ces deux ouvertures est faite au travers d'un second miroir. On aligne la réflexion de l'astre visé avec l'horizon en déplaçant l'alidade. La graduation sur le secteur donne alors l'angle sous lequel on "voit" l'astre visé. Un raisonnement simple permet de se rendre compte que, pour faire une lecture directe de la mesure, il est nécessaire de graduer l'arc de cercle par demi-degré. Ultérieurement on portera le secteur à un sixième de cercle pour donner ce qui est connu aujourd'hui sous le nom de sextant.

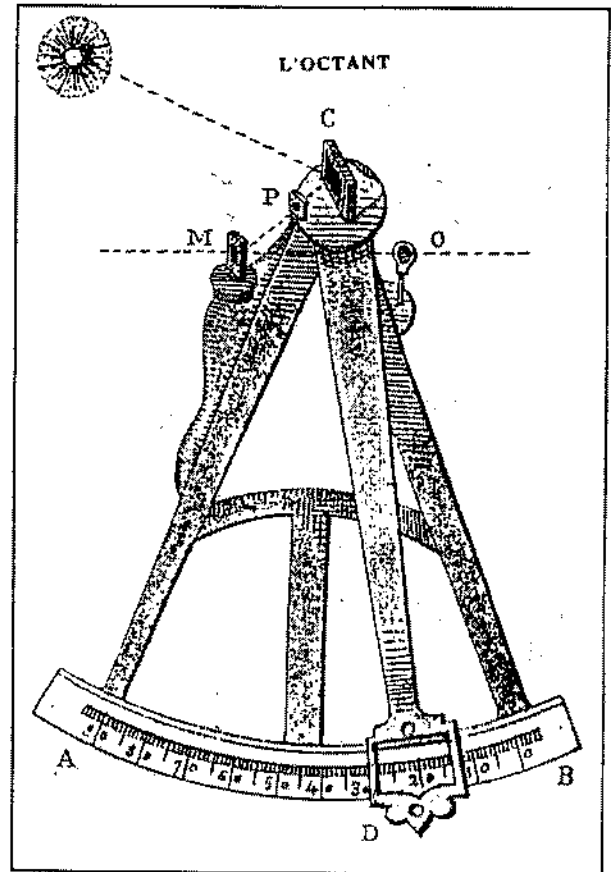

L'OCTANT PRINCIPE

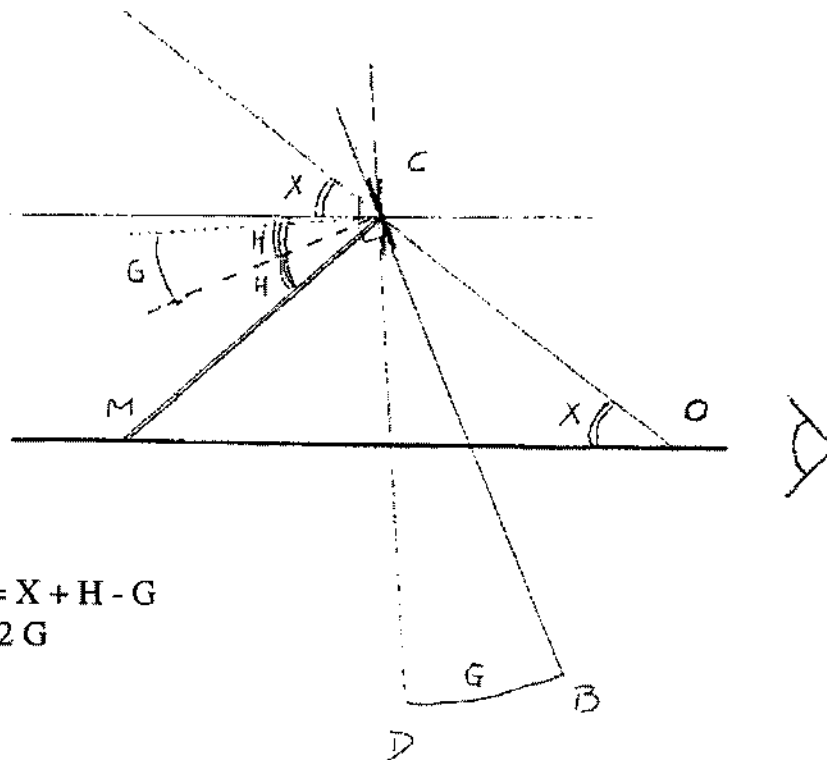

$$H + G = X + H - G$$

$$\Rightarrow X = 2G$$

La dernière partie du traité montre comment reporter sur une carte la route suivie, ou comment prévoir la route à suivre. C'est à nouveau un problème de représentation et son importance fait que BOUGUER doive expliquer en détail les techniques à utiliser.

L'ouvrage ne répondra pas tout à fait à la commande. Dès 1760 il est réédité, mais remanié et allégé par l'Abbé DE LA CAILLE. Celui-ci s'en explique dans la préface: l'édition de 1753 était trop volumineuse et trop chère pour être un vrai manuel; elle était plus adaptée aux enseignants qu'aux élèves "pilotes". Il était malgré tout nécessaire de connaître à priori certaines notions mathématiques et d'avoir l'habitude de les pratiquer pour aborder la lecture du "Traité de navigation" dans sa forme initiale. D'autre part le livre est encombré de passages mis entre guillemets, que l'auteur mentionne comme pouvant ne pas être lus par les débutants. Le format, le nombre de pages, le caractère théorique, et jusqu'au vocabulaire utilisé ne pouvaient faire de ce traité la référence que les marins du XVIIIème siècle auraient emportées à bord. Il fut pourtant réédité, tant dans sa forme initiale que dans la version remaniée, jusqu'à la fin du siècle. Cependant, les méthodes et techniques obsolètes, telles l'arbalestrille, disparurent au profit de la description d'instruments plus performants.

BOUGUER fut plus théoricien que navigateur. De plus, il n'avait plus enseigné depuis une douzaine d'années quand il a rédigé ce traité. Ses expériences concrètes se trouvent essentiellement dans les pratiques effectuées dans la première partie de sa vie, au Croisic, et dans son voyage en Amérique du sud. Une fois revenu en France, il ne quitta plus Paris. Mais, de ce fait, il a beaucoup écrit, en majorité sur des termes relevant de la physique et fut un des savants français les plus prolifique de son époque.

ANNEXE I

FORME DE LA TERRE

Si la Terre est sphérique, pour une différence de α° en latitude, la distance, à la surface, est la même.

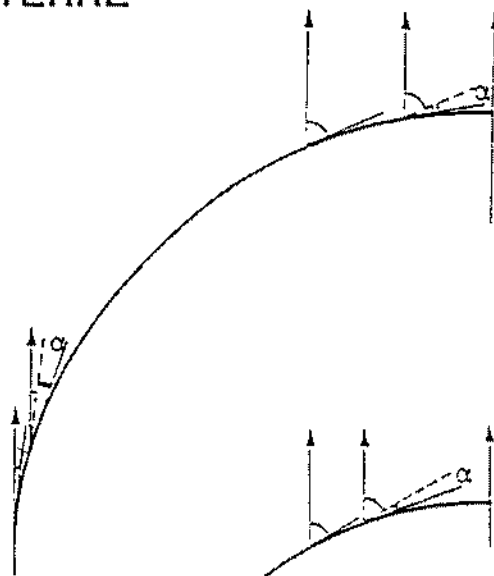

Si la Terre est aplatie à l'équateur, pour une différence de α° en latitude, la distance est plus longue à l'équateur qu'aux pôles.

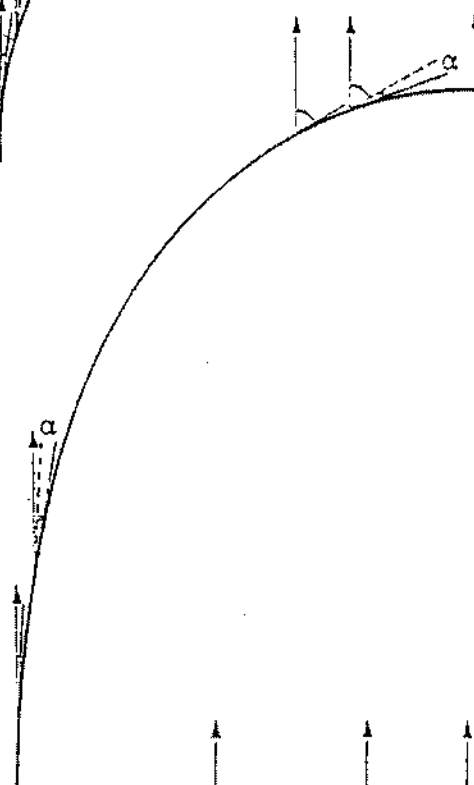

Si la Terre est aplatie aux pôles, pour une différence de α° en latitude, la distance, à la surface, est plus longue au pôle qu'à l'équateur.

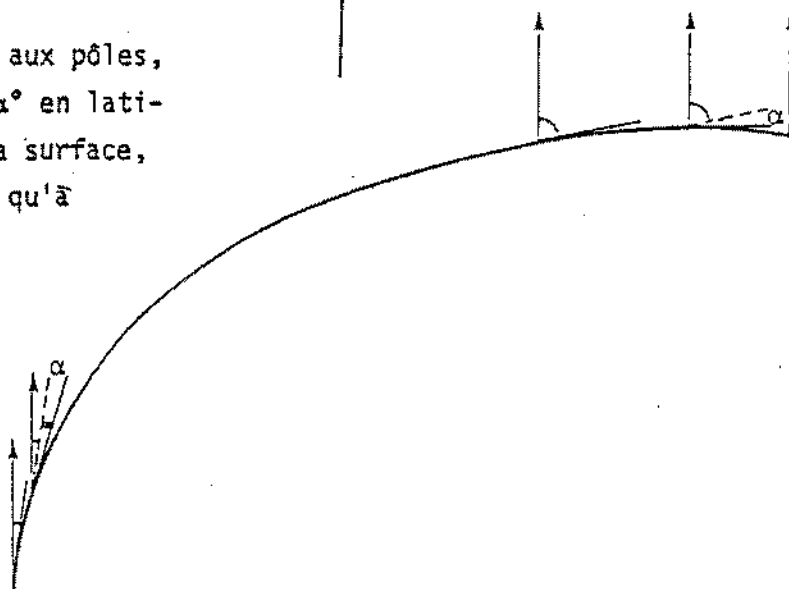

ANNEXE II

NOUVEAU TRAITÉ DE NAVIGATION PIERRE BOUGUER 1753

TABLE DES MATIERES

LIVRE I Dans lequel on donne les premières connaissances de géométrie qui sont nécessaires au pilotes	
ch1- Du cercle et de sa division en degrés	p3
ch2- Des différentes situations que peuvent avoir deux lignes droites l'une par rapport à l'autre	p7
ch3- Des triangles	p16
ch4- De l'échelle de dixme et de la construction de plusieurs autres échelles	p20
ch5- Usage des triangles semblables pour mesurer les distances inaccessibles, lever des plans	p23
ch6- De la résolution des triangles par le calcul	p32
Table des sinus, tangentes, sécantes et de leurs logarithmes	
Table de logarithmes	p46
LIVRE II Dans lequel on donne une idée générale du pilotage, en traitant de la figure et de la grandeur de la terre	p56
ch1- Des principaux points de la terre latitude longitude	p63
ch2- De la construction de la boussole	p75
ch3- De la manière de mesurer avec le loch	p95
ch4- De la construction des cartes marines	p111
ch5- Opérations sur les cartes et de leur usage	p121
ch6- Remarques générales sur la navigation, sur la manière de s'approcher de la terre de sonder	p137
ch7- Du flux et du reflux de la mer	p149
LIVRE III Dans lequel on donne les premières notions d'astronomie qui sont utiles aux navigateurs	
ch1- De la situation des étoiles fixes	p161
ch2- Des planètes (sphère armillaire)	p171
ch3- De la distinction des années bissextiles (table des ascensions droites et des déclinaisons du soleil)	p180
ch4- Du mouvement particulier de la lune	p202
ch5- Méthode plus exacte que celle de l'article III du chapitre précédent pour calculer les lunaisons	p213

LIVRE IV Usages qu'ont dans la navigation les différentes connaissances
d'astronomie données dans le chapitre précédent

- ch1-Méthode plus exacte ... pour trouver l'heure du flux et
du reflux p224
- ch2- Des moyens qu'on emploie pour observer la hauteur
des astres (arbalestrille, quartier anglais, octant) p233
- ch3-Des corrections qu'il faut appliquer à l'observation de
la hauteur des astres p250
- ch4- Moyen de trouver la latitude p268
- ch5- Moyen de déterminer l'heure qu'il est lorsqu'on est
en mer (table du lever et du coucher du soleil) p277
- ch6- Trouver l'amplitude ou la distance du lever et du
coucher du soleil au vrai point de l'orient et de
l'occident p300
- ch7-Connaissant le vrai rumb de vent... trouver la
variation p308
- ch8-Moyen de trouver immédiatement la longitude p313

LIVRE V De la résolution des routes navigables par diverses méthodes

Première section: Dans laquelle on explique la manière de
naviguer par le quartier de réduction

- ch1- Description du quartier de réduction p326
- ch2- Résolution des problèmes généraux de navigation par
le quartier de réduction p337
- ch3- Détail des opérations qu'on nomme corrections p353
- ch4- Des règles composées par le quartier de réduction p366

Seconde section: Dans laquelle on explique la résolution des
routes de navigation par diverses méthodes, soit en se
servant de la règle et du compas, soit en employant
uniquement le calcul

- ch1- De la réduction des routes par le compas de proportion
et par l'échelle des cordes simples p380
- ch2- Méthode de résoudre... en se servant des tables p391
- ch3- Méthode... par échelle de logarithmes p410
- ch4- De la construction des tables de latitudes croissantes p419
- ch5- Du changement que doit apporter dans toutes les règles
ou méthodes précédentes le défaut de rondeur de la
terre p434

GEOMETRIE DES ARPENTEURS DE L'ANTIQUITE AVEC DES ENFANTS DE 8 A 13 ANS

Patrice Johan, Institut Universitaire de Formation des Maîtres, Créteil, France

Le présent exposé tire ses origines de constats effectués sur l'enseignement de la géométrie dans des classes élémentaires françaises (enfants de 6 à 11 ans). Des études de manuels, des enquêtes dans les classes, des confidences de maîtres, nous ont conduits à des conclusions très préoccupantes: la géométrie est peu enseignée à l'école élémentaire, et lorsqu'elle l'est, les objectifs en sont très flous.

Nous nous proposons d'analyser rapidement les raisons de ces difficultés, puis de suggérer des activités que nous pensons être de nature à aider les maîtres dans cet enseignement difficile. Les activités en question ont été empruntées à l'histoire.

Dans l'histoire, on peut distinguer (en simplifiant) trois époques correspondant à des conceptions différentes de la géométrie:

- Une époque de "géométrie expérimentale" où elle est un ensemble de techniques de repérage et de mesurage, c'est celle des arpenteurs, des métreurs, des astronomes et des architectes.

- Une époque où, après les écoles de Thalès et de Pythagore, Platon et les platoniciens distinguent les êtres géométriques abstraits (et parfaits) des objets réels. La géométrie se constitue alors comme une science (ce stade peut être considéré comme atteint au 3ème siècle avant notre ère avec "les éléments" d'Euclide) et sa place est si grande dans les mathématiques que les termes *géomètre* et *mathématicien* sont synonymes.

- Une troisième époque débutera au tournant des XVIIIème et XIXème siècles avec la géométrie descriptive de Monge, la géométrie projective de Poncelet, l'apparition des géométries non euclidiennes (Gauss, Bolyai, Lobatchevski, Riemann) et l'intervention des groupes de transformations où la géométrie se détachera totalement du monde sensible, et où, finalement, elle cessera d'exister en tant que telle, pour n'être plus qu'une illustration particulière de structures mathématiques plus générales.

L'évolution historique des connaissances mathématiques évoquée ci-dessus montre que le rôle de la figure est constamment allé en s'amenuisant. Simple support du raisonnement dans la géométrie déductive héritée des grecs, son exactitude n'était même pas nécessaire (qui n'a entendu dire que la géométrie était "l'art de raisonner juste sur une figure fausse"?). Aux époques ultérieures, les "points" pourront être des nombres, des courbes, des fonctions... et la géométrie ne s'exercera plus sur des corps concrets de l'espace physique ni sur des figures mais sur des objets définis par des axiomes.

Si la détermination des contenus "officiels" d'enseignement se fait en tenant compte des "savoirs savants" des mathématiciens, elle se fait aussi en fonction des besoins culturels et sociaux de l'époque et de la société dans laquelle se place le projet éducatif. Le survol historique qui vient d'être fait montre l'évolution (relativement lente) des savoirs des mathématiciens; mais les besoins culturels et sociaux ont eux très vite évolué notamment dans cette seconde moitié du XXème siècle: la France d'aujourd'hui n'est plus celle des paysans et des artisans dans laquelle des connaissances d'ordre géométrique étaient indispensables (aires et périmètres en relation avec les clôtures ou les quantités d'engrais et de semence,

taille des pierres ou tracés des charpentes, etc...); sur ce plan également, la figure et ses procédés d'obtention ont perdu de leur importance.

Or, c'est à l'école élémentaire et aux premières années de collège que ce rôle de la géométrie (tracés de figures, premières définitions...) est traditionnellement dévolu. Les maîtres de ces niveaux se trouvent placés devant cette contradiction qui consiste à enseigner des connaissances qui n'ont plus guère de nécessité sociale et dont la nécessité mathématique semble très floue.

Il faut ajouter à cela que la majorité des maîtres d'aujourd'hui a été confrontée (à un moment ou à un autre de sa formation) à ce qui s'est appelé, en France, "la réforme des math. modernes". Ces programmes (en vigueur dans les années soixante-dix) se proposant de combler le fossé entre "la science déjà faite et la science qui se fait" avaient donc -conformément à ce projet- considérablement réduit la place de la géométrie pour les élèves les plus jeunes et développé aux niveaux supérieurs la géométrie analytique ou le calcul libère de la figure et remplace l'intuition liée à cette figure.

Toutes ces raisons peuvent expliquer les difficultés de l'enseignement de la géométrie à l'école élémentaire, mais en aucun cas elles ne peuvent justifier son abandon.

La géométrie déductive a toujours su garder son importance au collège (à partir de la classe de quatrième, soit vers 14 ans) en raison de la force irremplaçable de ses méthodes d'investigation, et en dépit de son aspect historique suranné. Cependant, les objets sur lesquels elle raisonne (ces concepts idéaux, cercles, triangles... indépendants de toute existence matérielle) ne peuvent pas se passer d'une élaboration préalable. **Un jeune enfant ne peut pas accéder directement à des abstractions que l'humanité a mis tant de siècles à construire.** Pour cette raison, il nous paraît indispensable que, dans les classes antérieures, l'enfant puisse s'interroger sur ses relations à l'espace, coordonner entre elles les informations qu'il tire de son environnement par ses yeux, ses mains et sa parole et que c'est au prix de constructions, de tracés, de savoirs empiriques qu'il pourra ultérieurement structurer intellectuellement le "stock" d'informations qu'il aura constitué. **A défaut d'un tel travail, il est à craindre que les élèves ne retiennent de l'enseignement secondaire qu'un discours formel d'où le sens serait absent!**

La difficile transition entre le réel sensible et les êtres géométriques abstraits peut être facilitée par un travail sur le **schéma**, représentation de la réalité, et sur son évolution en **figure** nécessaire à l'élaboration de la pensée. C'est sur ces étapes, renvoyant à la géométrie pré-hellénique, que les activités que nous avons choisies se proposent de s'appuyer.

Présentation des instruments et de leur usage

Nous allons donc proposer des activités dans lesquelles la géométrie retrouve une conception proche de celle de la première époque historique (celle des arpenteurs ...) et du passage de la première à la deuxième de ces époques (passage où l'objet géométrique abstrait naît progressivement du réel sensible).

Cette conception de l'activité géométrique présente, à nos yeux, l'avantage d'utiliser à la fois des éléments matériels, réels, concrets (les instruments, les objets

que l'on mesure) et des éléments abstraits, idéaux (les rayons visuels); elle permet également de s'intéresser tout particulièrement à l'articulation entre les deux types d'éléments, lorsque le dessin de la réalité devient la figure géométrique. Par exemple, des rayons visuels ou des cordes tendues seront facilement assimilés aux traits de crayon tracés le long de la règle, puis à des droites "abstraites"; les arbres, les instruments, devront passer par le truchement d'une schématisation pour finalement acquérir le même statut.

Les expériences décrites ci-dessous ont fait pratiquer par les élèves une "**géométrie de terrain**" inspirée des pratiques des arpenteurs et des topographes de l'Antiquité et du Moyen-âge.

Nous avons choisi des instruments "d'époque" destinés à effectuer des visées permettant de déterminer des distances inaccessibles: largeur d'une rivière, éloignement d'un bateau, hauteur d'une tour, d'un arbre etc... Leur usage se fonde sur les propriétés des triangles isocèles et/ou rectangles. La présence d'éléments réels sur l'instrument donnant existence à des triangles virtuels dans l'espace nous a paru être de nature à la fois à éveiller l'intérêt des élèves et à faire sentir le besoin de la notion même de triangle.

Nous avons comme objectifs, à partir de répliques de ces instruments, de faire manipuler les enfants sur le terrain, en leur présentant des situations stimulant leur intérêt et de les amener, par ces mesures réelles puis des croquis sur papier, à comprendre la nécessité d'acquérir des compétences dans la précision des figures et des connaissances des propriétés de certains triangles.

Les instruments:

a) L'instrument (dont il est fait état dans la *Géométrie* de Gerbert d'Aurillac au 10^e siècle¹) pour *mesurer des hauteurs dont le pied est accessible, le sol dans un certain rayon étant supposé horizontal* : il est constitué de deux bâtons ajustés perpendiculairement.

b) L'instrument signalé par Errard de Bar-le-Duc² (1594) pour *mesurer une distance horizontale dont une extrémité est inaccessible*. Il est constitué de deux bâtons "articulés" avec un frottement suffisant pour qu'ils gardent un angle choisi.

¹ Gerberti (postea Silvestri II papae) "*Opera mathematicae (972-1003)*" Berlin 1899, in-8°.

Le fait que Gerbert d'Aurillac ait été par la suite Pape (le Pape de l'an Mil: Sylvestre II) a beaucoup surpris et intéressé les enfants .

² "*La géométrie et pratique générale d'icelle*" Errard de Bar-le-Duc. Paris 1594.

Jean Errard, dit Errard de Bar-le-Duc (1554-1610), ingénieur militaire au service d'Henri IV et de Sully fut surnommé "le père de la fortification".

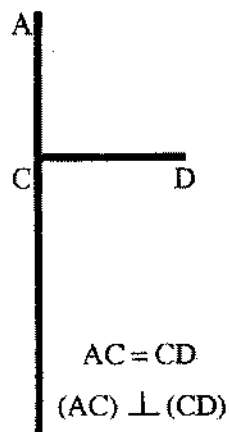

a) Instrument de Gerbert

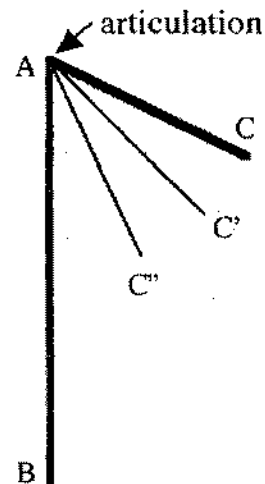

b) Instrument d'Errard

Ces deux instruments ont été munis d'un fil à plomb afin de s'assurer de leur positionnement vertical.

c) Une corde d'une vingtaine de mètres graduée tous les vingt centimètres (ou un décamètre usuel) pour mesurer les distances au sol.

Leur usage a été testé avec des élèves de 8 à 11 ans.

Deux autres instruments seront envisagés plus loin (l'un signalé par Gerbert, l'autre par Errard) pour être expérimentés avec des élèves plus âgés (11 à 13 ans)

Compte-rendu des séances en classes primaires.

Les enfants sont placés devant la situation problème: *comment faire pour mesurer la hauteur du grand sapin qui est dans la cour?*

Les propositions sont nombreuses (certaines fort acrobatiques) mais la mise en commun et le débat font aisément reconnaître leur inadaptation.

Nous leur montrons l'instrument "de Gerbert d'Aurillac": *voici l'instrument avec lequel on faisait ce genre de mesure dans l'Antiquité et au Moyen-âge, comment pouvait-on bien faire?*

Après discussion, l'idée que *l'on va viser le haut* est reconnue comme pertinente. *Il faut tenir le bâton bien droit* émerge également, la présence du fil à plomb sur l'appareil ayant intrigué les enfants.

Nous n'avions (à dessein) pas montré la corde et l'idée d'une mesure au sol n'a pas été émise.

La décision est prise d'aller dans la cour pour procéder à l'exécution de cette tâche.

Les enfants, en groupes, observés par le maître et nous-mêmes, parviennent à placer l'instrument en bonne position, c'est-à-dire vertical (*bien droit!*) et visant le haut de l'arbre. Ils marquent alors au sol l'emplacement du pied de l'instrument.

- *Comment utiliser ces marques de craie? Comment vont-elles nous permettre de trouver la hauteur de l'arbre?*

- *Si on se met plus loin, on vise plus haut! Si on se met plus près on vise plus bas!*

- *Il n'y a qu'à mesurer à quelle distance on est de l'arbre!*

Ces réponses (authentiques) sont le résultat d'un tri parmi des interventions nombreuses.

Un triangle "virtuel" émerge:

ses sommets:

- le faîte de l'arbre,

- le pied de l'arbre,

- la place de l'instrument (ce sommet-là devra être modifié par la suite, mais cela pourra se faire en classe).

ses côtés:

- l'arbre,

- la "ligne" qu'on va mesurer au sol,

- le rayon visuel.

C'est de ces trois éléments si différents: un arbre, une ligne que l'on pourrait tracer (que l'on peut parcourir) et "quelque chose" de totalement virtuel, que va émerger cette notion **géométrique** commune: **le côté d'un triangle**.

On mesure alors la distance entre le pied de l'arbre et le pied de l'instrument. Comme les élèves ont compris que cette distance est d'autant plus grande que l'arbre est haut, ils sont alors persuadés qu'ils ont la réponse cherchée.

En classe: *Vous allez dessiner ce que nous avons fait l'autre jour pour trouver la hauteur de l'arbre.* (le support est un papier quadrillé)

Après un premier jet, on procède à une mise en commun, au cours de laquelle apparaît la nécessité de:

- utiliser les lignes du quadrillage pour représenter l'arbre, l'instrument et le sol.

- aligner les points A et D de l'instrument avec le sommet de l'arbre.

- bien dessiner l'instrument. C'est à ce moment que son observation (motivée) montre que ACD est rectangle et isocèle.

Nous sommes ici au stade crucial où le schéma représentant la réalité va devenir figure prenant en compte des propriétés.

On dessine à nouveau la situation, et on constate que la distance entre le pied de l'arbre et le pied de l'instrument (SB) n'est pas égale à la hauteur de l'arbre dessiné (figure 1).

- *Alors, on n'a pas trouvé la hauteur de l'arbre l'autre jour?*

- *Non, mais revenons au dessin. Le petit triangle ACD est rectangle et isocèle, n'y en a-t-il pas aussi un grand?*

Le triangle "intéressant" n'est pas celui auquel on pensait, mais celui obtenu en prolongeant le rayon visuel vers le sol. Il est rectangle et isocèle et on trouve au sol une distance égale à la hauteur de l'arbre.

- *Mais ce n'est pas celle que l'on a mesurée, il va falloir recommencer!*

A ce stade, il a fallu aider les enfants à "voir" le troisième triangle rectangle isocèle, ABS' (figure 2); AB est donc égal à BS' , il suffit alors d'ajouter à la distance SB "de l'autre jour" la hauteur AB de l'instrument.

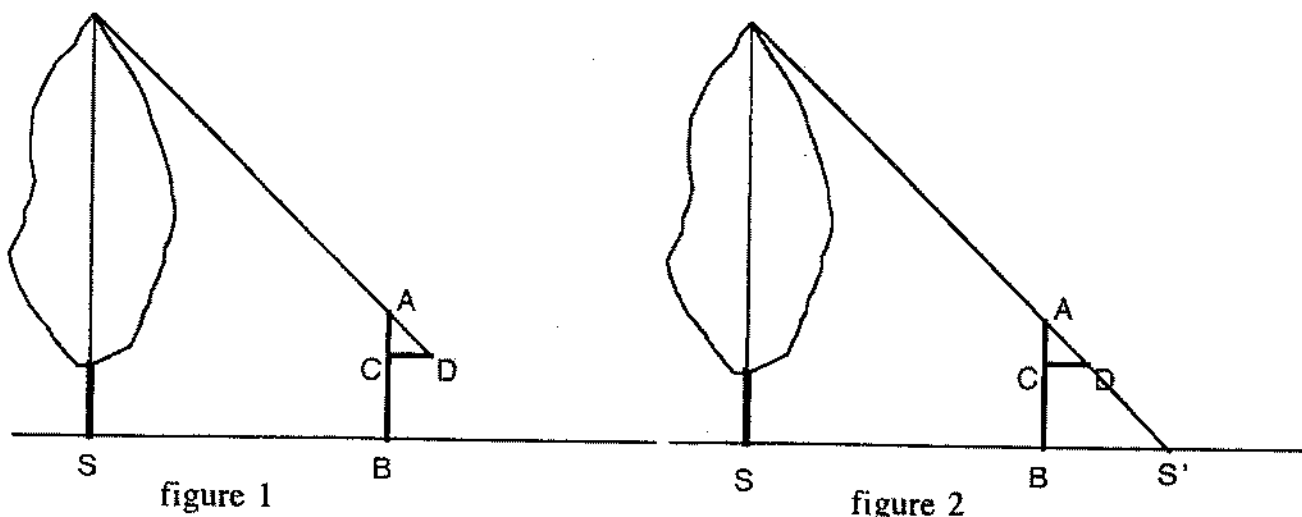

On connaît la hauteur de l'arbre. Elle diffère légèrement d'un groupe à l'autre: 12,60 m, 12,80 m, 13,20 m; la précision est satisfaisante pour nous (5%), mais non pour les enfants: *Qui a bon?*

Pour la nouvelle activité (détermination de distances horizontales inaccessibles), la démarche pédagogique sera similaire:

1) énoncé de la situation problème: "nous sommes au bord d'une rivière impossible à traverser et dont nous voudrions connaître la largeur",

2) recherche individuelle,

3) mise en commun, discussion,

4) nous montrons l'appareil (instrument d'Errard)

5) observation, mise en relation avec le problème posé...

Les élèves découvrent rapidement que:

- l'instrument doit, ici encore, être placé verticalement,

- il doit être au bord de la rivière,

- le bâton articulé doit "viser" l'autre rive.

Mais que faire de cet angle que "garde" l'instrument?

Nous serons en possession d'un triangle virtuel, rectangle (horizontale/verticale) dont, cette fois, un côté (l'instrument) sera connu, ainsi qu'un angle:

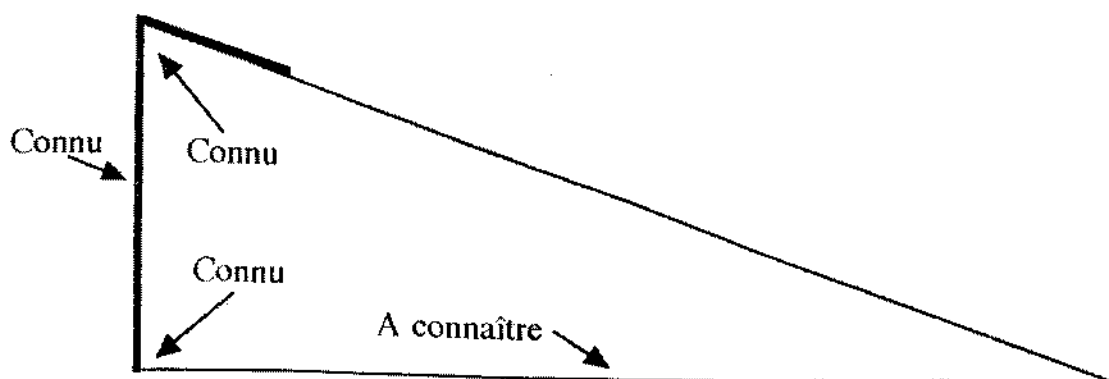

L'idée est émise de tourner l'instrument vers la terre ferme:

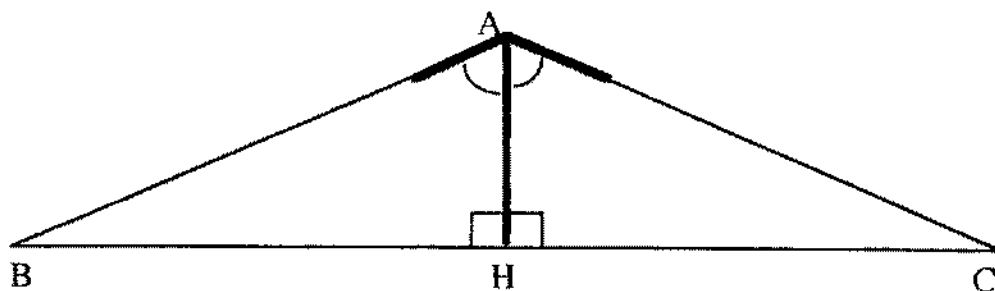

Dans son traité, Errard démontre que les triangles AHC et AHB sont égaux. En ce qui nous concerne, en CM2, nous nous contentons de faire observer que les propriétés de la figure (angles en A égaux et angles droits en H) confèrent à (AH) un statut d'axe de symétrie ce qui permet à ABC d'être perçu comme isocèle. La nécessité d'effectuer la visée dans un plan perpendiculaire à la rive n'apparaîtra que sur notre sollicitation, et fournira le contenu de la séance suivante.

Le seul "procédé" que connaissent les enfants pour la construction des perpendiculaires (l'utilisation de l'équerre) permettra-t-il de résoudre le sous-problème qui leur est posé: "comment effectuer la visée perpendiculairement à la rive?" ou encore: "trouver un point *juste en face*, sur la rive opposée".

On a, bien sûr, déjà compris qu'il faudra tracer sur la terre ferme une perpendiculaire à la rive où nous sommes (et non mettre une équerre dans l'eau!).

Après avoir rappelé aux enfants, la construction d'un triangle de côtés connus à l'aide du compas (et en avoir construit quelques-uns sur papier uni), nous faisons observer la propriété des triangles de côtés 3 cm, 4 cm, 5 cm (ou 6, 8, 10 ou 9, 12, 15...) d'être rectangles. Cette propriété admise sans difficulté (l'observation de plusieurs exemples a suffi!) nous fournit un nouveau procédé de construction des perpendiculaires, dont nous nous servirons sur le terrain en traçant, à l'aide de notre corde graduée, un triangle de côtés 3, 4, 5 (en mètres)³.

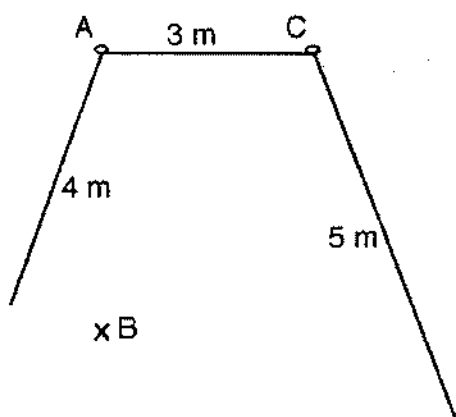

La corde est tendue entre deux piquets plantés au sol dans les boucles A et C. Les extrémités des deux brins libres tendus décrivent des arcs de cercles qui se rencontreront au point cherché B.

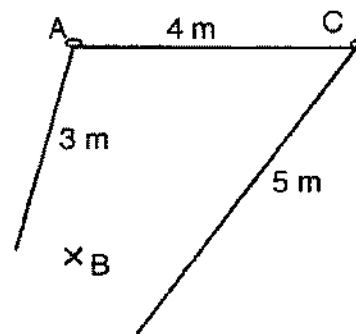

Le déroulement est conforme aux prévisions. Les résultats obtenus montrent une précision du même ordre que dans les activités précédentes (5% d'écart entre les mesures extrêmes).

³ Les charpentiers (et les carreleurs) utilisent couramment ce procédé sous l'appellation: "tirer un trait carré".

Expériences en classes de collège

Parmi les ancêtres des instruments d'arpentage et de topographie, beaucoup utilisent les propriétés des triangles rectangles semblables; les propositions d'activités suivantes trouveront aisément leur place dans les premières années de collège (enfants de 11 à 13 ans).

L'un des instruments que nous avons choisis est constitué d'une équerre placée à l'extrémité d'un bâton et articulée avec celui-ci. Là encore, à l'articulation, le frottement doit être suffisant pour que l'équerre garde sa position par rapport au bâton lorsqu'on déplace l'ensemble.

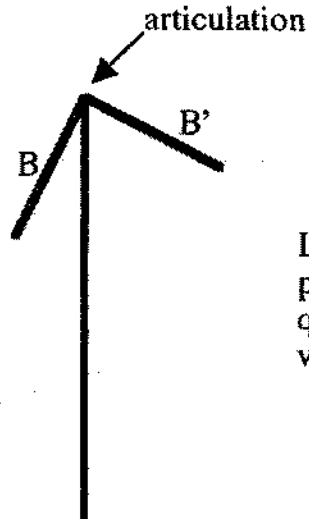

Les branches B et B' sont perpendiculaires, et c'est l'équerre BB' qui, à l'articulation, pivote dans un plan vertical.

Dans les cas de grandes distances horizontales inaccessibles il permet de mesurer au sol des distances plus petites:

On a, bien entendu: $BC = SB^2/AB$ (voir figure ci-dessous)

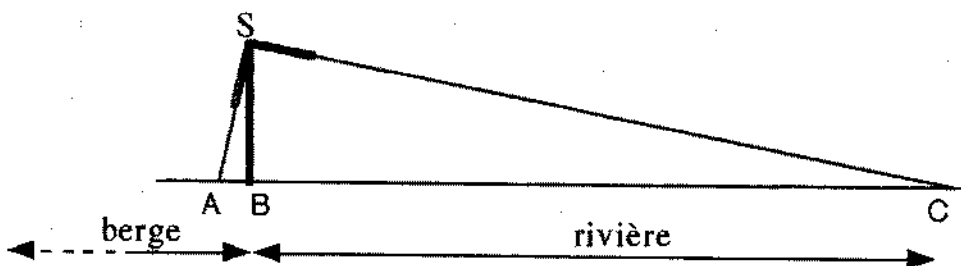

La notion de triangles semblables et la proportionnalité des côtés nous ont semblé difficiles pour des élèves de cet âge, mais il a été possible de leur faire sentir la propriété sur laquelle se fonde l'usage de cet instrument, en procédant de la façon suivante:

Sur feuille, chacun mène en un point H d'une droite D une perpendiculaire (AH) telle que $AH = 6$ cm, puis les élèves placent un point B sur D, les uns à 6 cm de H, d'autres à 4 cm, 3 cm ou 2 cm. Ils doivent ensuite construire C sur D de sorte que ABC soit rectangle en A. On mesure ensuite HC. On réunit finalement les résultats dans un tableau:

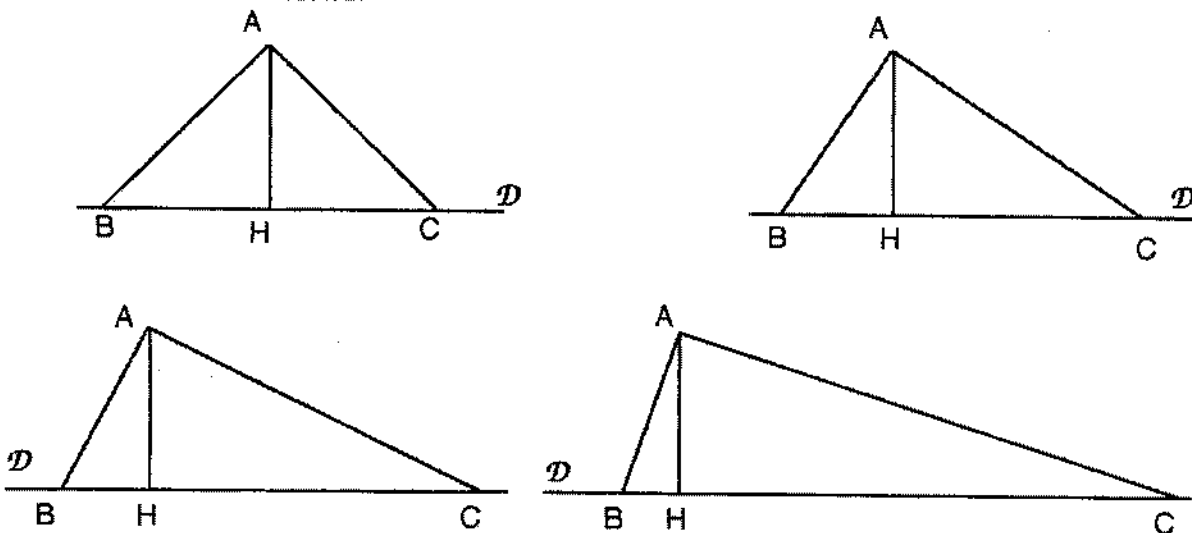

AH	AH ²	HB	HC	HB x HC
6	36	6	6	36
6	36	4	9	36
6	36	3	12	36
6	36	2	18	36

On observe alors que (pour AH fixé) HB et HC varient en sens inverses, quand l'un diminue l'autre augmente, et que cette variation respecte une "certaine loi". Il est alors facile de voir que si l'on connaît AH et HB, on peut calculer HC.

Lorsqu'on l'utilise pour des hauteurs, cet instrument présente l'avantage de pouvoir être placé en n'importe quel endroit pour faire la visée, ce qui n'était pas le cas pour le premier instrument (celui de Gerbert).

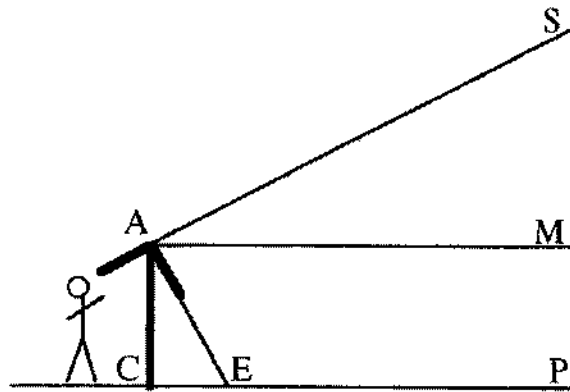

L'instrument est placé en un endroit quelconque C, on mesure PC. Une des branches vise le sommet de la hauteur inconnue, l'autre branche détermine alors au sol un point E (par visée) dont on mesure la distance à C. Les triangles ACE et AMS sont semblables (angles égaux), leurs côtés sont proportionnels et trois d'entre eux sont connus: AC, CE, AM (qui est égal à CP). On peut alors calculer SM puis en déduire SP.

Le dernier instrument que nous ayons utilisé est signalé dans la *Géométrie de Gerbert* (déjà citée), il se résume à une simple équerre dont les deux branches ont des longueurs de 30 cm et 40 cm (ou d'autres dimensions dans le même rapport) fixée (ou non) à l'extrémité d'un bâton, nous l'appelons "Gerbert 2". Il permet, moyennant l'utilisation d'une proportionnalité simple (de coefficient 3/4 ou 4/3) de déterminer des hauteurs.

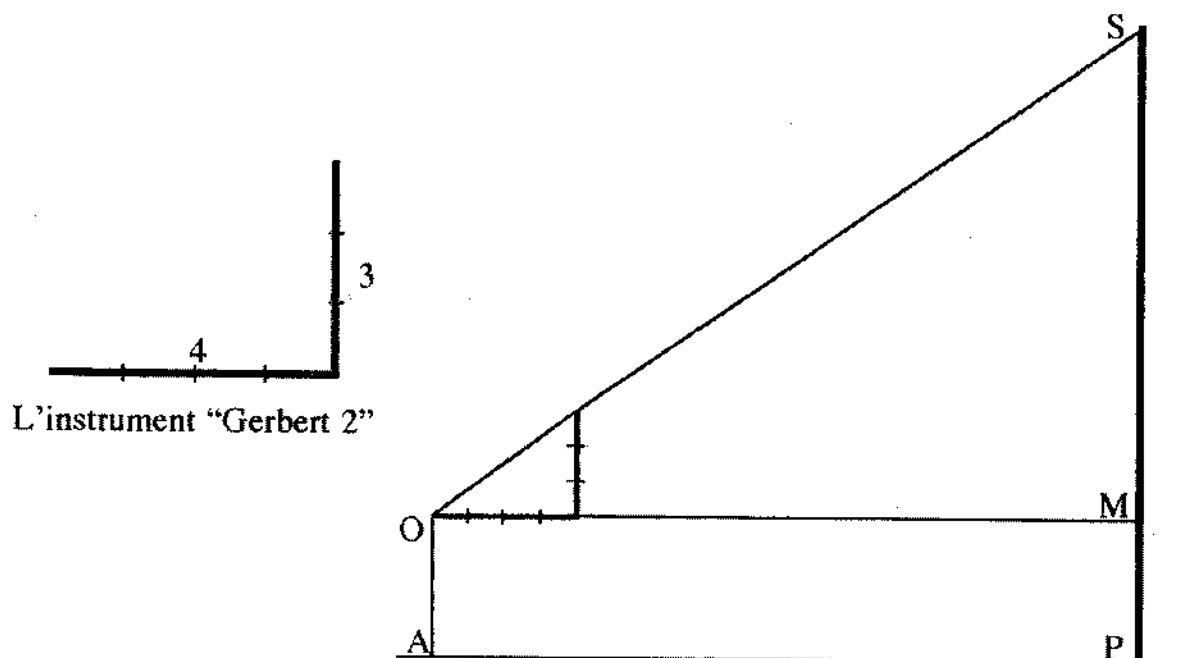

L'observateur se place de façon à viser le point S lorsque (par exemple) le petit côté de l'équerre est vertical. On mesure AP (ce qui donne OM), on mesure OA (distance de l'œil de l'observateur au sol). SM vaut les $\frac{3}{4}$ de OM (rapport des côtés de l'équerre). Il suffit alors d'ajouter OA à SM.

Le premier instrument de Gerbert obligeait à faire la visée à une distance du pied pratiquement égale à la hauteur cherchée, celui-ci offre deux possibilités de placement (l'une plus proche, l'autre plus éloignée). La panoplie constituée des deux instruments permettra donc une plus grande liberté.

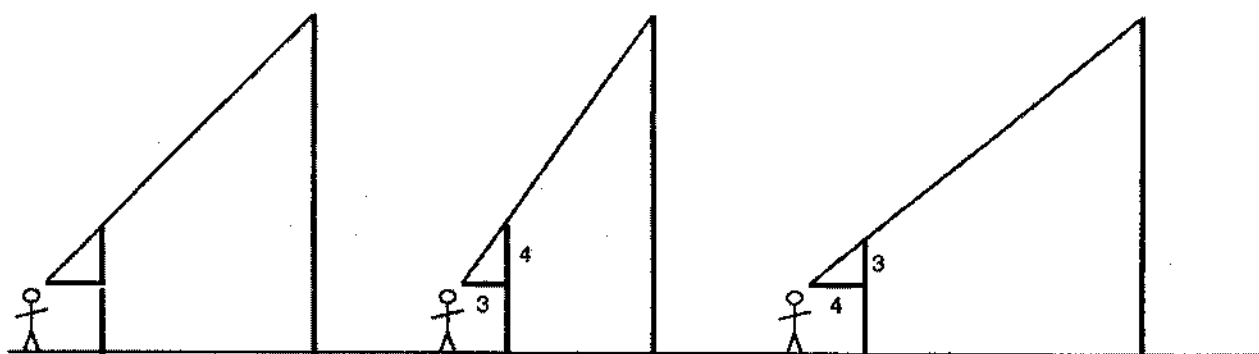

La position du premier instrument comparée aux deux positions possibles de l'instrument "Gerbert 2" ..

Conclusion

Pour conclure cet exposé, je voudrais commencer par citer mon amie Evelyne Barbin:

"Une figure géométrique peut avoir au moins deux statuts [...] représentation d'éléments d'une réalité construite [...] représentation de concepts idéaux d'une théorie. Le premier statut, celui de schéma, est souvent négligé dans l'enseignement et, en tous cas, le passage d'un statut à l'autre est ignoré. Or, ce passage, qui correspond au clivage entre enseignements primaire et secondaire, désigne une étape importante dans la construction du sens de la figure géométrique. L'absence de cette étape conduit, à mon avis, à l'une des principales difficultés auxquelles se heurte l'enseignement de la géométrie au collège. Un apprentissage de la démonstration sur des objets dont le sens n'est pas construit ne peut que produire un non-sens chez la plupart des élèves."⁴

Les activités décrites dans cet exposé ont souhaité insister sur cette étape dont parle E. Barbin, étape où le schéma, représentation de la réalité, devient figure "abstraite", nécessaire à l'élaboration de la pensée. La vie quotidienne, présente et à venir, de nos élèves étant passablement "dégéométrisée" (combien d'entre eux

⁴ Evelyne Barbin: contribution à la table-ronde "Le rôle de la démonstration dans l'étude des figures géométriques" Le Quesnoy, Juin 1994. Article à paraître.

auront à arpenter des champs? combien deviendront charpentiers ou tailleurs de pierres?), nous avons demandé à l'Histoire de nous fournir les situations nécessaires. En dépit de leur caractère un peu artificiel (*Ils n'avaient rien d'autre à faire les Grecs que de mesurer des arbres?* ainsi que nous l'a fait remarquer un enfant de CM2) ces activités peuvent être un bon support pour motiver les enfants à tracer des figures géométriques en leur donnant du sens: les rayons visuels devenant des droites, les arbres devenant des segments, les positions devenant des points qui, à leur tour, engendrent des triangles, triangles dont l'étude des propriétés est nécessaire pour atteindre le but fixé... sont autant d'éléments de cette construction de sens.

MATEMÁTICAS E TÉCNICAS

Ubiratan D'Ambrósio, Universidade de S. Paulo, Brasil

Conceituar Matemática é uma tarefa difícil. O mais usual é pensar Matemática como "Ciência que investiga relações entre entidades definidas abstrata e logicamente" (*Novo Dicionário da Língua Portuguesa*, 1986) ou "a science that deals with the relationship and symbolism of numbers and magnitudes and that includes quantitative operations and the solution of quantitative problems" (*Webster's Third New International Dictionary*, 1971). Obras mais antigas não diferem na conceituação. A *Encyclopédie, ou Dictionnaire Raisonné Des Sciences, des Arts et des Métiers*, 1757, diz no verbete Mathématique: "c'est la science qui a pour objet les propriétés de la grandeur entant qu'elle est calculable ou mesurable".

Na verdade, a palavra Matemática começou a ser usada no século XIV e no sentido mais próximo ao que mencionamos acima somente a partir do século XVII. Sem dúvida, está relacionada com a raiz grega *mátēma*, que significa o que se aprende. Há espaço para interpretar essa raiz como explicação, entendimento. A busca de uma capacidade de explicar as coisas que o impactam, de conhecer a natureza, de lidar com a natureza é notada desde cedo na evolução da espécie. O desenvolvimento de maneiras de explicar, de conhecer, de lidar com a natureza e com os fenômenos naturais é, portanto, presente em todas as culturas. Com um abuso etimológico podemos construir a palavra matemá-tica com esse sentido, que certamente inclui as definições dadas acima.

Particularmente interessante é identificar essas práticas e suas teorizações com as religiões, as artes e as técnicas propriamente ditas. Quando falamos em prática estamos nos referindo ao fazer. Mas o fazer implica um saber. Quem faz está sabendo -- que é a essência do livro *arbitrio*. Ora, o saber permite

* Rua Peixoto Gomide 1772/83; 01409-002 São Paulo, SP, BRASIL.
tel: 55-11-280.0266 fax: 55-11-282.5437 e-mail: ubi@usp.br

fazer, que é a essência da inteligência.² A dicotomia saber/fazer, bem como intelectual/manual, mente/corpo, espiritual/material, teoria/prática e inúmeras outras variantes que hoje estamos tentando superar, são resquícios da distinção aristotélica entre *episteme* e *techné*. A percepção de uma relação simbiótica entre todas essas dicotomias está ligada a uma percepção da essência de ser humano, que é a busca solidária de sobrevivência e de transcendência, inerente a todas as ações.³ Ora, nesse sentido amplo podemos identificar práticas e suas teorizações em todas as culturas, na forma de diferentes etno-matemáticas.

Nas buscas de sobrevivência e de transcendência a espécie humana desenvolveu meios de lidar com o ambiente mais imediato, que fornece o ar, a água, os alimentos, o outro, e tudo o que é necessário para a sobrevivência do indivíduo e da espécie. São as técnicas e os estilos de comportamento. Mas ao mesmo tempo foram se desenvolvendo as percepções do que se respira, do que se bebe, do que se come, de como se relacionar com o outro e igualmente meios de se lidar com o ambiente mais remoto, passado e futuro, fonte de experiências acumuladas necessárias para a sobrevivência. A memória, individual e coletiva, e as artes divinatórias, que permitem perceber o futuro, essenciais para a sobrevivência, são ao mesmo tempo as primeiras instâncias da transcendência. Na memória estão a história e as tradições, que nos falam sobre o que aconteceu. Nas artes divinatórias estão envolvidas todas as tentativas de se saber o que ainda está para acontecer, a astrologia, os oráculos, a lógica do *I Ching*, a numerologia e finalmente as ciências.

Neste trabalho estamos interessados em analisar como essas práticas e as teorizações associadas se desenvolveram na Europa, em particular nos séculos XVI, XVII e XVIII. Mas para isso é importante uma rápida vista sobre o que se passou nas civilizações que mais diretamente influenciaram a formação da mentalidade européia nesse período, que são as civilizações da antiguidade clássica, Grécia e Roma.

Na Grécia, de acordo com a historiografia mais aceita se localiza o nascimento da Matemática e igualmente da Filosofia. Nos diz René Thom que aí se

². Veja a belíssima obra de ficção de George G. Simpson: *The Dechronization of Sam Magruder*, St. Martin's Press, New York, 1996. O livro, escrito por um grande paleontólogo, tem prefácio de Arthur Clarke e posfácio de Stephen Jay Gould, fala sobre Sam Magruder, um cientista do século XXIII, especialista em viagens no tempo, que é jogado para 80.000.000 de anos no passado.

³. Ver meu livro *Transdisciplinaridade*, Editora Palas Athena, São Paulo, no prelo.

distinguem um corpo de conhecimentos teóricos, voltado à explicações -- *mathématique de l'intelligibilité* -- e um outro prático, voltado às aplicações -- *mathématique de la maîtrise*. Na verdade a distinção se faz nas explicitações, isto é, nas tentativas de contar e transmitir o que se faz, registrar o que se fez, o que não nos diz sobre o processo cognitivo envolvido na elaboração desses conhecimentos.⁴ Essas duas explicitações da matemática são amplamente reconhecidas e não contestadas em Arquimedes, Ctesíbio, Herão e vários outros. Já em Roma reconhece-se um predomínio das *mathématique de la maîtrise* nas explicitações, o que tem levado alguns historiadores a dizer que não houve matemática em Roma! O livro de Marcus Vitruvius Polio *De Architectura*, em dez partes, escrito no século I a.C., nos mostra muito claramente a existência de uma matemática voltada à finalidades imediatas e claramente associada a reflexões de natureza teórica. Não há preocupação em explicitar a teorização das práticas, o que é uma característica do pensamento romano no que se refere aos conhecimentos de natureza científica.

A medida que vai se avançando pela Idade Média, as artes divinatórias -- isto é, as ciências -- vão se organizando, intelectual e socialmente, subordinadas ao corpus de conhecimentos então vigentes. A Astrologia e Religião tem uma posição privilegiada nessa organização. Dentre essas, a Matemática.

Procuramos identificar, no período da organização da Matemática, a influência das técnicas. Eu diria mesmo que Matemáticas e Técnicas se desenvolveram em simbiose. Assim, conclui-se que outros enfoques no lidar com a natureza levam, necessariamente, ao desenvolvimento de um outro corpo de conhecimento que poderá ter pontos de encontro com a Matemática, mas que tem uma organização intelectual -- epistemologia -- distinta. Procuramos fazer um estudo comparativo do desenvolvimento das técnicas nos séculos XVI, XVII e XVIII e identificar a utilização de conhecimentos matemáticos anteriores para satisfazer as necessidades dessas técnicas emergentes. E ao mesmo tempo reconhecer como esses conhecimentos foram sendo modificados e aprimorados para satisfazer novos requerimentos das técnicas e se organizando num corpo de conhecimento com especificidades, até ser capaz de alimentar seu próprio desenvolvimento. De uma certa forma, criar as suas próprias necessidades de fazeres/saberes, fechar-se num universo próprio de estímulos e motivações. Reconhece-se essa autonomia do conhecimento

⁴. Pode-se dizer que a história tem sido feita, particularmente a história da matemática, sobre o que ficou. Seria muito importante fazer a história do processo cognitivo envolvido, uma forma de meta-cognição histórica. Este é um dos objetivos do Programa Etnomatemática.

matemático somente mais tarde, no século XIX, quando o fazer/saber matemático é um objetivo em si. Antes dessa época, o objetivo era exterior ao corpo de conhecimento.

Seria extremamente simplista ver nos comentários acima uma insinuação da inutilidade da matemática nesse estágio de alimentar-se de suas próprias motivações. Pois ao torna-se um corpo autônomo de conhecimentos ela se incorpora ao conjunto de fatos disponível para como informação e recursos no processo de explicar, de conhecer, de lidar com a natureza e com os fenômenos naturais. De que maneira pode servir, não podemos saber. Daí o interesse em se divulgar toda a matemática disponível, sem necessariamente dizer que vai ser útil para isto ou aquilo. Simplesmente são recursos -- fatos -- disponíveis para o ser humano sobreviver e transcender. De que maneira? Não podemos saber.⁵

A organização do tempo e do espaço são fundamentais para a análise histórica. Com relação ao tempo, é interessante notar em um quadro que se encontra em Siena mostrando uma reunião de cientistas em 1576, discutindo a reformulação do calendário proposta por Gregório XIII, argumentando sobre os signos do Zodíaco, evidenciando a presença da Astrologia nas discussões astronômicas, o que é raramente lembrado na História das Ciências. A marginalização de formas de conhecimento então vigentes provocam distorções na interpretação da evolução da Ciência, sugerindo uma linearidade fictícia. Como diz Gérard Fourez no seu interessante estudo sobre a ética das ciências, "...a história da ciência freqüentemente suprimiu a sua dimensão histórica. Ao escrevê-la, só raras vezes se buscou reencontrar a singularidade do passado; pelo contrário, procurou-se mostrar o desenrolar do progresso científico, percebido em geral como inexorável e tão linear quanto o universo de Laplace....A história da ciência assemelha-se portanto aos raciocínios apresentados nos artigos científicos: só se relata aquilo que, *a posteriori*, parece útil, racional, científico. Desse ponto de vista, o 'progresso' avança sempre com uma lógica implacável, racionalizando os caminhos percorridos para se chegar onde se está."⁶

⁵. Mais uma vez recorro à excelente metáfora proposta por G. G. Simpson na obra citada na Nota 2. A matemática, e na verdade todo o conhecimento, não se enquadra numa imagem que muitos tem, de um jogo de contas de vidro do Herman Hesse. Em outros termos, não há conhecimento inútil.

⁶. Gérard Fourez: *A Construção das Ciências. Introdução à Filosofia e à ética das Ciências*, trad. Luiz P. Rouanet, Editora UNESP, São Paulo, 1995 (copyright original 1988); p.167.

Obviamente, ao se tratar dessa maneira a história das idéias dominantes no mundo moderno, está-se sugerindo uma inevitabilidade dos sucessos sociais e políticos e portanto um conformismo paralisador do progresso social. Particularmente prejudiciais são as implicações dessas distorções na Didática das Ciências, sobretudo na organização curricular e metodológica.

Ao longo da história, a relação entre saberes científicos e técnicos sempre foi íntima, ao contrário do que diz, em sintonia com a concepção dominante de ciência, Giles-G. Granger: "Quando os saberes técnicos ainda não estão impregnados de conhecimento científico".⁷ Mas o que Granger está efetivamente dizendo é impregnados de conhecimento científico hoje reconhecido como tal. Em outros termos, tem-se falado do conhecimento do passado com a ótica do conhecimento de hoje. Um certo maniqueísmo tem dominado essa forma de se fazer história das ciências.

Vou tentar ilustrar essa observação examinando o que se passou com a Arquitetura na transição do Renascimento. Assim estarei ilustrando o que quero dizer com a simbiose entre a Matemática e as Técnicas. Os grandes tratados da época, em especial *De re aedificatoria*, de Leon Battista Alberti (1404-1472), *Architettura*, de Sebastiano Serlio (1475-1554) e *I Quattro Libri dell'Architettura*, de Andrea Palladio (1508-1580), ao retomar Vitruvius vão dando ao corpo de conhecimento matemático uma organização própria. Esses três livros, bem como o de Vitruvius, são disponíveis em fac-símiles da Dover Publications, Inc., das edições em inglês publicadas respectivamente em 1775 (Alberti), em 1611 (Serlio) e em 1738 (Palladio).

Nesses três clássicos fica evidente a importância atribuída à obra de Vitruvius, embora se reconheça que este não dava uma fundamentação matemática, típico da atitude romana com relação à matemática, isto é, conhece-la e utiliza-la, mas não se preocupar com as teorizações. Naturalmente, o conhecimento matemático prossegue na Idade Média cristã sem ser reconhecido como tal. Desenvolve-se vertentes novas de conhecimento em duas direções fortemente relacionadas: uma prática sofisticada que se manifesta nas Artes plásticas e na Arquitetura e a construção da Filosofia Cristã. A vertente que chamamos *mathématique de l'intelligibilité* está presente na obra religiosa, que culmina com a *Summa Teologica* de São Tomás de Aquino. No desenvolvimento das

⁷. Giles-Gaston Granger: *A ciência e as ciências*, trad. Roberto Leal Ferreira, Editora UNESP, São Paulo, 1994 (copyright original 1993); p. 36.

técnicas, nas pinturas de Giotto e Cimabué e no estilo gótico reconhecemos a *mathématique de la maîtrise*. E a influência mútua está evidenciada nas três obras mencionadas.

Também é muito interessante um estudo comparativo com novas formas de Arquitetura das civilizações "descobertas" pelos europeus nessa época e com os esforços dos conquistadores e colonizadores interferirem na organização local de espaço -- cidades -- e de tempo -- trabalho -- com uma organização específica de idéias de natureza matemática.⁸ Na construção de minas no México, a teoria utilizada na Espanha, baseada na obra de Agricola, *De re metallica* (1528), mostrou-se inadequada. Foi necessário um novo instrumental matemático, que se teorizou com a denominação "geometria subterrânea", para lidar com a situação nova.

O livro de Alberti, estruturado em dez livros, de modo semelhante ao de Vitruvius, mostra uma preocupação teórica com Matemática: "Como organizar os ângulos [na construção do alicerce] não seria fácil explicar usando apenas palavras; o método pelo qual eles são desenhados é derivado da matemática e requer ilustrações gráficas. Além disso, seria estranho ao nosso objetivo aqui, e de qualquer modo o assunto já foi tratado em outra obra, o nosso *Comentários Matemáticos*." Isto mostra a existência de um estudo específico de fundamentação teórica, num certo sentido propedêutico, para a arquitetura. A *Commentarii rerum mathematicarum* de Alberti é uma obra desconhecida. No livro IX, capítulos 5 e 6, Alberti discute as proporções, com freqüente referência à mística dos números e teorizações sobre média aritmética e geométrica. A regra de três é mostrada como sendo um instrumental necessário para as construções, mesmo em se considerando assuntos de natureza mais filosófica que técnica.

Em Serlio encontramos uma Geometria propedêutica. O tratado é dividido em cinco livros, sendo os dois primeiros dedicados à Geometria básico, essencialmente um tratado de Perspectiva, fortemente inclinado a teorizações mas sempre se referindo aos casos concretos da arquitetura.

Enquanto em Alberti há uma clara referência a uma Matemática necessária para o arquiteto e Serlio nos dá efetivamente uma introdução matemática antes de

⁸. Veja o importante estudo de José Sala Catalá: *Ciencia y Técnica en la Metropolitización de América*, Theatrum Machinae, Madrid, 1994.

entrar na arquitetura propriamente, Palladio utiliza livremente o que de matemática é necessário para tratar os problemas da arquitetura. Embora fortemente orientado à estética, a matemática utilizada é um tanto sofisticada, mas é assumida como conhecida, o que pode revelar o fato de a matemática ter se incorporado à cultura do arquiteto, o que é muito significativo para ilustrar a crescente incorporação da matemática à técnica. Em outros termos, a matemática se mostra o instrumental teórico essencial da técnica.

MATHEMATICS AND MUSIC

John Fauvel, The Open University, UK

In 1920, the nineteen-year-old Werner Heisenberg attended a Youth Congress in a castle deep in the Bavarian Alps. A number of young people of southern Germany met to discuss truth, values, the future, order and disorder, in the light of Germany's recent defeat in the Great War. The arguments were getting more and more complicated, heated and confusing when an event took place which seems to have been a pivotal moment in Heisenberg's development, in the growing understanding which led him to the Nobel Prize for physics only twelve years later.

Quite suddenly a young violinist appeared on a balcony above the courtyard. There was a hush as, high above us, he struck up the first great D minor chords of Bach's Chaconne. All at once, and with utter certainty, I had found my link with the centre. . . . The clear phrases of the Chaconne touched me like a cool wind, breaking through the mist and revealing the towering structures beyond. There had always been a path to the central order in the language of music, . . . today no less than in Plato's day and in Bach's. That I now knew from my own experience.

Werner Heisenberg, *Physics and beyond*, Allen & Unwin 1971, p.11

In recognising that music provides a path to the central order, the young physicist was rediscovering for himself a truth which has been known for well over 2000 years, and probably far longer than that. One of the earliest fragments we have of ancient Greek thought is a remark made by the Pythagorean Archytas of Taranto, who lived in the early fourth century BC. Talking about the scientific thinkers who have come before, he remarks

And so they have handed down to us clear knowledge of the speed of the heavenly bodies and their risings and settings, of geometry, numbers and, not least, of the science of music. For these sciences seem to be related.

Archytas of Taranto, early C-4

This hint became greatly developed and explored as time went by. These four subjects, astronomy, geometry, arithmetic and music, have lived on as a connected bundle, what was later called the quadrivium. This does indeed provide an epistemological classification of our ways of understanding. If you grant a Greek distinction between *quantity* and *magnitude*—'how many?' and 'how great?', if you like—the relation between the elements of the quadrivium was explained in this way by Proclus in the fifth century:

Arithmetic, then, studies quantity as such, music the relations between quantities, geometry magnitude at rest, spherics magnitude inherently moving.

Proclus, *Commentary on the first book of Euclid's Elements*, C5

These four subjects constituted mathematics, and were taught in this way throughout the Middle Ages, as four of the seven liberal arts (the others being

grammar, logic and rhetoric). As the English scholar Roger Bacon explained in the late thirteenth century,

This science [mathematics] is the easiest. This is clearly proved by the fact that mathematics is not beyond the intellectual grasp of any one. For the people at large and those wholly illiterate know how to draw figures and compute and sing, all of which are mathematical operations.

Roger Bacon, c. 1265—*Opus Majus*, 4, iii.

This may seem fanciful at first sight—even while encouraging for mathematics teachers!—but we may note that the belief that in doing music you are really doing mathematics is now deep in western culture. Five and a half centuries later Leibniz was saying essentially the same thing:

Music is a hidden exercise in arithmetic, of a mind unconscious of dealing with numbers.

G. W. Leibniz, letter to Goldbach, 17.iv.1712

Let us not worry about words and categories: whether music is a part of mathematics isn't really the point; here I only want to establish that for well over 2000 years they have been seen as intimately connected. Nor is this a purely historical connection. Recent research in the United States has shown that musical training improves childrens' mathematical abilities: classes of five- to seven-year olds given special music lessons became better at mathematics than a control group after only seven months. There does appear to be something about the way that musical training stretches the mind, or acts on the mind, which provides mental skills transferrable to other areas, to mathematics in particular, and good teachers have always known this.

The Greek insight

Let me go back to the beginning of the story now and look at why music and mathematics have for so long been seen as intimately connected. In doing this I am not going to trace a single story-line, but rather to look at some of the range of ways in which connections can and have been made: from simple numerical correlations to deep facts about the universe; from the mathematical structure of the scale to the structuring of musical works; from the design of the cosmos to the experiences of young people in whom a fondness for mathematics and for music often go together. The richness of the many and very different ways in which connections have been found has been of immeasurable benefit to the development of both subjects and their teaching, and there are direct classroom benefits from exploring this material.

You probably know of the fundamental Greek insight, attributed to Pythagoras, that music and number are ultimately, deeply, the same thing, because of the amazing fact that beautiful, consonant sounds arise from string lengths in simple ratios of numbers. So I won't spend much time on this, other than observing that there are many teaching possibilities here which develop mathematical understanding. One thing to explore is the basic idea of ratio and proportion, and how these can be represented in the notation of fractions. Then

for the right pupils there is an opportunity for work with fractions which feeds back into musical sounds, as when you discover the difference between an 'octave' (1 : 2) and a 'fifth' (2 : 3) to be $1/2$ divided by $2/3$ ie 3 : 4 (a 'fourth'). Or to put it another way, a fifth (2 : 3) plus a fourth (3 : 4) is an octave (1 : 2); $2/3 \times 3/4 = 2/4 = 1/2$. Another thing to explore is the way different means—arithmetic mean, geometric mean and harmonic mean—form ways of finding lengths in between two others with different properties. So the geometric mean of lengths a and c is the length b such that a is to b as b is to c , or $a/b = b/c$, or b is the square root of ac . Or in musical terms, the string length such that the two musical intervals are equal, whereas the arithmetic mean produces a length halfway between, but giving rise therefore to unequal musical intervals. I think this is really quite a valuable way of helping pupils understand, in a context other than statistics, why or how there can be different means or averages.

At another level, the way in which addition of musical intervals corresponds to multiplication of ratios, and subtracting intervals corresponds to division of ratios, is an intriguing result of a kind which we later find at the heart of the idea of logarithms (I don't suggest any historic link, though the French historian Paul Tannery explored the possibility.) So one way and another there's a wonderful richness of material from Greek harmonic theory yearning to be used in the mathematics classroom, and indeed which was a staple of mathematics education well into the late Middle Ages and Renaissance.

The major Pythagorean insight that mathematics and music are deeply the same provided a "path to the central order" (in Heisenberg's words) for many subsequent mathematicians and other thinkers, reaching its zenith in the sixteenth and seventeenth centuries. The whole cosmos was seen, by thinkers in the tradition of Pythagoras and Plato, as harmonically structured with correspondences between the planetary orbits, the human body and soul, and the elements, all bound together with the intervals of musical harmony. Such a worldview is used by Shakespeare, for example, when he has Richard II speak of his sad state in prison:

How sour sweet music is
When time is broke and no proportion kept!
So is it in the music of men's lives,
And here have I the daintiness of ear
To check time broke in a disordered string,
But for the concord of my state and time
Had not an ear to hear my true time broke.

This was not a purely poetic conceit, but an important component of some scientific thinking, notably in the work of Johannes Kepler whose book on the *Harmonies of the world* both discussed the music of the spheres, showing the polyphony of the planets in six-part counterpoint, and contained his third law of planetary motion.

Equal temperament

There is actually a major problem with the Pythagorean scale, that is, taking the notes determined by these simple ratios and filling in a few more to make a scale. This is the question of what happens when you choose another starting note for the scale—a different key, in other words. The notes of the new scale don't quite coincide with notes of the old one. Various solutions to this problem have been advanced, the most successful of which, adopted in the early 18th century, was to construct a so-called 'equal-tempered' scale. This involves considering the octave as divided into twelve equal intervals, each exactly the twelfth root of 2. So the 'fifth' is then $2^{7/12} = 1.4990$ which is fairly close to the Pythagorean value of $3/2 = 1.5$ but not exact, and similarly for the others.

Whatever the solution to the problem, a interesting mathematical issue arose with fretted string instruments such as lute and guitar: how to determine where the frets should be placed so that the instrument can be played in a variety of keys? There was a great deal of activity on this front in the seventeenth and eighteenth centuries.

Mathematical structure in music

Mathematics and music are not only related at the cosmic and instrumental levels. The mathematical form of music is something which has intrigued both musicians and commentators. Some compositional devices, such as fugue or canon, have obvious mathematical correlations: the geometric operation of translation in this case. Some composers have written works which have other symmetries, such as reading the same forwards and backwards, or which are the same when you turn the music upside down. In a more serious vein, several composers have used mathematical ideas to structure their compositions. The Hungarian composer Bela Bartok is a case in point. And in the area of change-ringing, of ringing bells in a constantly permuting order, the group structure of the performance—group structure in a mathematical sense—has long been known and indeed revelled in by its aficionados.

Over-enthusiastic analysis, however, can find mathematics which may not be there. For a century or more there has been a great cultural enthusiasm for the golden section, or golden ratio, a ratio which was certainly well known to the Greeks, though not by that name (it is that division of a line which establishes the proportion *smaller : larger* is as *larger : whole line*). Commentators have found this ratio, and the related Fibonacci series, in many of the arts as well as in nature. It takes quite careful analysis, such as that of John Putz recently, to establish that Mozart (in his case) did not set out to use the golden section as some writers have hoped. On the other hand, mathematics can also be a productive analytical tool or language for discussing musical structure. Work by the Swiss researchers Kenneth and Andrew Hsü has shown that Bach's music can be analysed by fractals, in order to show something about

the relation between small and large sections of the music, but without making any claim that the eighteenth century composer J. S. Bach knew anything about fractals (any more than fish know anything about fluid dynamics).

In this vein, I am not quite sure how to read the analogy made by the geometer H. S. M. Coxeter:

It is, perhaps, not too fanciful to compare the form of a Beethoven sonata with the structure of a typical mathematical theorem and proof, such as Pythagoras' proof that the square root of two is irrational.

In the mathematical procedure we can trace the occurrence of an Introduction (a motivation for the theorem), an Exposition, with its First Subject (the enunciation of the theorem itself), Transition (remark), and Second Subject (a Lemma or subsidiary theorem that will be needed later on), a Development (the proof of the theorem itself), a Recapitulation, and a Coda.

This analogy seems to illuminate the mathematics (which is in any case only dubiously connected with Pythagoras in this form) rather more than the music. I suspect that "fanciful" is exactly what this comparison is.

Mathematicians and musicians

Several of the great mathematicians have written works on music, starting with Euclid who is supposed to have written an *Elements of music*. This is now lost, but a short work on *Division of the scale* is attributed to him. Among the more recent mathematicians, one of the greatest was Leonhard Euler. His *Tentamen novae theoriae musicae* (1739) has received a mixed press. It was memorably described by David Brewster, at the beginning of the 19th century, as "too much geometry for musicians and too much music for geometers". And one American writer was even more caustic, saying "Were his authority in such matters not so great, it might perhaps be said that he had missed the point of the whole subject." [Safford 1859]. Interestingly, the book that this American thought very highly of was written by an English contemporary of Euler, Robert Smith's *Harmonics* (1759), remembered today as the founder of the Smith's mathematical prizes at Cambridge.

Of course, being interested in music theory is not the same as being musical, or enjoying music. Isaac Newton, notoriously, "never was at more than one Opera. The first Act, he heard with pleasure, the 2nd stretch'd his patience, at the 3rd he ran away." More tellingly still, perhaps, on hearing Handel play upon the harpsichord, Newton "could find nothing worthy to remark but the elasticity of his fingers" [Gouk, 101]. A similar story is told of Niels Henrik Abel, who had little interest in music but one day was seen to be unusually attentive to a friend's piano-playing; he explained he was trying to find a relation between the number of times each key was struck by each of the player's fingers.

Many mathematicians have been very musical, though, all the way from Bolyai, who was a violinist, Cardano and De Morgan (who played the flute), to Poincaré, Stevin and Brook Taylor. There is a well known story about Albert Einstein rehearsing a violin sonata with the great pianist Artur Rubenstein, who is supposed to have said at one particularly frustrating place in the rehearsal, "The trouble with you, Einstein, is that you can't count." This is the kind of story which if it isn't true it ought to be—so maybe isn't.

Thus far we've been looking particularly at mathematicians with musical interests (or not), but it has worked the other way round too. The great English mediaeval composer John Dunstable was celebrated as a mathematician and astronomer in his own day, and Mozart is an example of a musician with intense mathematical interests all his life. His sister recorded that when Mozart was learning arithmetic, he "talked of nothing, thought of nothing but figures", and the manuscript of his *Fantasia and fugue in C major* has on it his calculation of the probability of winning a lottery [Putz, 276]. Mozart's interest in numerological aspects of composition has been well explored by Ivor Grattan-Guinness, sometimes with quite convincing results.

At their best, mathematicians and musicians have for centuries tried to understand just what their disciplines have in common and how they complement each other. The great 19th century mathematician James Joseph Sylvester, whose enthusiasm for music extended to taking singing lessons from Gounod, wrote

May not Music be described as the Mathematic of Sense, Mathematic as the Music of reason? the soul of each the same! Thus the musician *feels* Mathematic, the mathematician *thinks* Music,—Music the dream, Mathematic the working life,—each to receive its consummation from the other when the human intelligence, elevated to the perfect type, shall shine forth glorified in some future Mozart-Dirichlet, or Beethoven-Gauss—a union already not indistinctly foreshadowed in the genius and labours of a Helmholtz!

J.J. Sylvester, 'Algebraical researches containing a disquisition on Newton's rule for the discovery of imaginary roots', *Phil. Trans.* 154 (1865), 613

Musical notation

I want to end, though, on a rather crisper note, with one of the most interesting, yet not well-explored, aspects of interaction between music and mathematics: the area of musical notation. Both sciences have developed notational issues over a long time. In the case of European music, the fourteenth century was crucial, in what was called *Ars nova*, the new art. Philippe de Vitry was making a notational and conceptual change in which written notes could take values either two or three times the next note value. This may sound rather a small detail, but it had major consequences which involved greater variety of rhythm, a larger range of note lengths, greater structural control of the musical material, and more shapely melodic lines with the voice parts having the

possibility of moving more independently. It was truly one of the most revolutionary developments in all music.

What has this *ars nova* to do with mathematics? There are two considerations: the people concerned in the musical developments and the general level of numeracy or mathematical awareness in the circles that produced and consumed this sort of work. All the young intellectuals promoting the *ars nova* were people who had studied the quadrivium, mostly at the University of Paris, and you can pin down specific contacts between mathematicians and musicians during the period. For instance, De Vitry asked the Provençal mathematician Rabbi Levi ben Gerson (c. 1288-1344) to write a work *De numeris harmonicis* about the mathematical justification for the *ars nova*'s use of double and triple divisions simultaneously. And most strongly, the culture needed to understand, sing, perform and appreciate the new music was and had to be an arithmetical culture, precisely that in which Europe was becoming more alert to the new numeration, the Hindu-Arabic numerals with their powerful new feature of being computational numerals, numbers for computing with.

I leave this provocative thought with you: maybe the Greeks were right, music and mathematics *are* the same thing, and that this is the best explanation for these analogies and relationships we've been exploring. If so, the reason may be that expressed some years ago by the German writer Victor Zuckerkandl:

In mathematics, just as in music (and nowhere else), doing is inseparable from thinking; more than that, in both doing is identical with thinking. What is true of tones is also true of numbers: to think them is to create them.

Victor Zuckerkandl *Sound and symbol*, 1956

Bibliography and further reading

- Archibald, R. C., 'Mathematicians and music', *American mathematical monthly* Jan 1924, 1-25
- Coxeter, H. S. M., 'Music and mathematics', *Mathematics teacher* 61 (1968), 312-320
- Field, J. V., *Kepler's geometrical cosmology*, Athlone Press 1988
- Gouk, Penelope, 'The harmonic roots of Newtonian science', in John Fauvel, Raymond Flood, Michael Shortland and Robin J Wilson (eds), *Let Newton be!*, 1988, 100-125
- Grattan-Guinness, Ivor, 'Counting the notes: numerology in the works of Mozart, especially *Die Zauberflöte*', *Annals of science* 49 (1992), 201-232
- Grattan-Guinness, Ivor, 'Some numerological features of Beethoven's output', *Annals of science* 51 (1994), 103-135

- Kassler, Jamie Croy, 'Music as a model in early modern science', *History of science* 20 (1982), 103-139
- Knobloch, Eberhard, 'Harmony and cosmos: mathematics serving a teleological understanding of the world', *Physis* 32 (1995), 55-89
- Lewin, Roger, 'The fractal structure of music', *New Scientist* 4 May 1991, 19
- Putz, John F., 'The golden section and the piano sonatas of Mozart', *Mathematics magazine* 68 (1995), 275-282
- Safford, Truman Henry, 'Researches in the mathematical theory of music', *Mathematical monthly* 1 (1859), 308-312
- Szamosi, Geza, 'Polyphonic music and classical physics: the origin of Newtonian time', *History of science* 28 (1990), 175-191

MATHEMATICS AND CULTURE

Mathematics is a construction of the human mind closely linked to **Culture**, understood as the area in which spiritual and creative human activity unfurls. Mathematics has not developed linearly and its content has not simply accumulated throughout history but it has been the result of the different cultural components of each historical period and, at the same time, a decisive factor in their global configuration.

If we compare the results of mathematics in two great cultures of the Ancient World: the Greek and the Chinese, through their compiler books : “The Thirteen Books of the Elements” (Euclid/ beginning c. III B.C.) and “The Nine Chapters on the Mathematical Art” (c. I B.C.), we will see two completely different attitudes related to the same figures and geometrical forms.

Of all the manifestations of the Greek genius none is more impressive than that which is revealed by the history of Greek mathematics. As “The Elements” shows, mathematics are for the Greeks fundamentally geometry. Certainly there is some arithmetic in the “Elements”, but considered as a theoretical discipline (theory of numbers) and not as an art of calculation (Logistic). It is clear that the euclidean text has no intention to make concessions to a practical utility.

Mathematics had, also, a very great development in Ancient China and if they developed no Euclidean deductive geometry, there was plenty of empirical geometry there. In any case, like the ancient Babylonians, the Chinese always preferred algebraic methods, and indeed by the thirteen century A.D., they were the best algebraists in the world.

The contents of the “Nine chapters on the mathematical art” are closely connected with practical life, reflecting the collective wisdom and abilities of the people of ancient China. The book is presented in question and answer form. It contains a total of 246 problems; each chapter has a specific title: “Field measurements”, “Cereals”, “Distributions by proportion”, “construction consultations”, “Fair taxes”, etc...

But, I will now focus on my main purpose: to show you that modern mathematics, that which has led to the scientific revolution of our occidental culture, although, heir to Greek mathematics, is essentially different from it. In our opinion, there are two main differences between them:

- The first is related to the concept of “infinite” and the way the infinite processes, which emerge when we try to apprehend reality using the reason, are treated.

- The second is linked to the conception of Nature. For the Ancients, Nature is admired and imitated by man. For the Moderns, Nature is an object, while man sets himself up as a subject, perceiving the world as a system of objects both alien to him and “mute” with respect to its own ultimate purpose.

For the Greeks, Nature was a model, mathematics a source of virtue; the beauty and rationality of the universe were the highest manifestations of good and Greek science was equivalent to "virtue" because its focus, the Cosmos, was their preeminent ethical model.

For Ortega y Gasset "*it is an obvious fact that the euclidean method, the exemplary rigor of the "geometric more" has its origin in ethics*".

And from ethics to aesthetics: Plato identified the beautiful with the good in the unity of perfect reality. Ancient Greece, until Euclid, considered Geometry an art more than a science such as we understand it today. Platonic ideas about the COSMOS, harmoniously organized in accord with preexisting and eternal archetypes, endowed with Symmetry, in the original sense of the word, as something well proportioned and in which the parts are in agreement with the whole, designed a Geometry with the desire to capture the real world. Greek Geometry measures the relationships of magnitude, size and shape among solid bodies. It is a geometry of finite space, of small distances, wherein the paradigm is the human body.

But at some point in the first half of the fifth century B.C. a discovery takes place that is terrible for Pythagorean arithmetic: the existence of incommensurable magnitudes. Natural numbers are no longer sufficient to quantify and measure all of the straight line segments produced by geometrical constructions. Perceptible reality for a Greek is Apollonian, and the appearance of incommensurable magnitudes and of infinite processes is disturbing to Hellenic serenity. The great mathematician Eudoxus of Cnidus developed an entire complicated theory of proportion (which later will constitute Book V of Euclid's "Elements") and in this manner the theory of similarities in geometry is also saved. The same Eudoxus shows how to save the difficulty of infinite processes with the so-called method of exhaustion, where one arrives by *reductio ad absurdum* at the equality of two areas or volumes, demonstrating that, if a difference between them exists, it would be smaller than any number no matter how small.

Eudoxus is the great master of the infinite in antiquity and Aristotle the authority who called for the prohibition of "actual" infinity, both physical and mental. Aristotle, the great scholar of this Culture, compiler of all learning from his era, vetoes the concept of infinity as something strange, imperfect, indeterminate, unnameable. Aristotle has shown that something invented by Reason itself can represent a danger for Reason: "*but the consideration of infinity bears a difficulty (aporia), so that affirming its existence becomes as impossible as affirming its nonexistence*" (physics 203 b 30-32).

Ever since Zeno of Elea, in the 5th century A.D., brought the emerging Reason to an impasse by confronting it with certain infinite processes, the History of Mathematics has been a continuous dodging of the difficulties which those processes bring with them. Aristotle came out badly in his confrontation with the aporias of Zeno; the lesser evil is to accept the infinite divisibility of a segment, but only "potentially," in a process of successive divisions, and not "actually" as an infinite collection given exhaustively from all its points.

This "prohibition" of actual infinity, however, does not impede mathematicians from developing their lines of reasoning: "*Our discourse is not trying to suppress the research of mathematicians by the fact of ruling out the existence of actual infinity. In reality, they (the mathematicians), in the present state, do not feel the need for infinity, and in reality they do not use it, but instead only a quantity as large as one wishes, although always finite...*" (Physics 207 b, 31).

In 300 A.D. Euclid, following Aristotelian directives, compiles and organizes all of existing mathematics, endowing it with an axiomatic-deductive structure which was the model for 2,000 years for any discipline that sought to be scientific and rigorous. We must not confuse the geometry of Euclid with the "Euclidean geometry" that we (pervaded with infinitude) understand today. There is not a single passage nor commentary in the "Elements" that indicates the idea of an infinite space (plane).

And with Euclid stand the other two great mathematicians who shape the Golden Age of Greek mathematics: Apollonius of Perga and Archimedes of Syracuse. Apollonius's treatise on conics has to wait hundreds of years to be understood and applied to the natural sciences. Archimedes, great scholar of antiquity, is the one whose characteristics most prefigure those of the modern scientist. He improves Eudoxus's technique of exhaustion and constructs an authentic Calculus, exquisitely respectful of the Aristotelian ban on the use of actual infinity, which does not stop him from using rather unorthodox but tremendously beautiful and imaginative techniques, in order to achieve results that he will later demonstrate in Geometry, that is, in the rigor of the Greeks, with the method of exhaustion. It is in 1906 that the Danish philologist Heiberg discovers in a palimpsest the Mechanical Method of Archimedes, in which the latter explains to his friend Eratosthenes, librarian of Alexandria, his method of discovering results which he later proves correct through other means.

And I would like to emphasize the close relationship between Mathematics, Art and Beauty in the Greek period. Mathematics itself is an Art, and thus Aristotle says in his Metaphysics (Book XII, cap. III): "*The forms that best express beauty are order, symmetry and precision. And the mathematical sciences are the ones which pay attention to these especially.*"

In summary, the Greek world is finite, harmonious, Apollonian, removed from extremes (*horror vacui, horror infinitus*) and its mathematics is an admiring reflection of the Cosmos and admirable fruit of human reason.

It is with the advent of the Christian God, endowed with infinite attributes and who rewards with eternal bliss or punishes with eternal damnation, that the immense, the infinite will gradually and subtly pervade western thought and culture.

In the fourth century, the neo-Platonic Saint Augustine, bishop of Hippo, constructs the Christian theology in harmony with the most profound ideas from Greek philosophy, but in disobedience of the Aristotelian precept he accepts the existence of "actual infinity" in the mind of God. Says Saint Augustine in his book "De civitate Dei:"

"Each number is characterized by its property, so that any two numbers are different; therefore, numbers are distinct and taken singularly they are finite and taken together they are infinite. God, then, because of his infinitude, knows them all. How would it be possible for the Science of God to know some numbers and ignore others? Would not he who maintained this be demented?"

Written with the passion characteristic of Saint Augustine, this passage will take on exceptional importance in the development of the mathematics of Infinity. Thus, he inaugurates a procedure through which man will resort to the divine figure in order to approach and manipulate the mathematical infinite.

Already in the 13th century, Thomas of Aquinas, more reflective and less enthusiastic, will say: *"...if actual infinity can exist according to the nature of things, or even if it cannot exist in this manner by virtue of an impediment which is not the very reason for infinity, I affirm that God can make infinity exist in an actual way. But if actual existence contradicts infinity by virtue of its very reason, then God cannot produce its existence, just as he could not make man be an animal that does not reason..."*

It is Saint Thomas who officially incorporates the scientific corpus and the Aristotelian vision of the cosmos into the doctrines of the Church. It is the physics of "common sense" which governs the Universe, itself finite, where each thing is in its place, and where the arched roof of the fixed stars revolves around the Earth and Man, center of the World by the will of Almighty God.

But the artist constructs the Gothic Cathedral, expression of an awed sense of the limitless which longs for infinity, and music, the Dionysian art, will fill the space with infinite sonorities by means of that gigantic instrument which is the organ. Art shows the way for Philosophy and Science: Nicholas of Cusa and Giordano Bruno speak of an infinite universe; there is a new rebirth of Platonism; Copernicus and Galileo shake the foundations of the Aristotelian-Ptolemaic cosmology and a new geometry will be developed, in accord with the new spiritual ordination of an open world, the Geometry of Descartes.

Lest we jump ahead of ourselves, now is the time to mention the figure that Jorge L. Borges would place in the central chapter of his unfinished history of the infinite: the Cardinal Nicholas of Cusa; who, influenced by Saint Augustine, will initiate certain close and long lasting relationships between Christian Theology and the Mathematics of Infinity.

Cusa continually combines theology with mathematics, whose figures (those of geometry) lend themselves to an ideal "infinitezation" which causes them to coincide with their opposites, thanks to which human intelligence gains access to the ineffable and "unfigurable" infinite. There is a virtual immanence of the infinite in each finite mathematical figure which only the "intellectual" mathematics can transmute gradually. It is thus that an infinite circle will coincide with the infinite straight line and the "infinitezation" of the figures cancels out the laws which rule rational

mathematics, which works with abstract but limited and quantifiable figures. The infinite figure thus acquires a meta-mathematical value which makes it suitable for try to apprehend the simple Infinite. The mathematical figure is converted into a theological figure.

Nicholas of Cusa is an early figure in this crucial period of our History which has come to be named the Renaissance, a period of rupture, the 15th and 16th centuries, in which the New World is being opened up. Copernicus, Bruno, Kepler and Galileo build a new vision of the Universe, limitless, disturbing, in which man ceases to be the center of a cosmology which is already made up of infinite worlds.

In 1623 Galileo publishes his book "Il saggiatore" in which for the first time he explains his scientific method, the new way of "questioning" Nature:

"Philosophy is written in that immense book which we have open before our eyes, in other words, the Universe, but it cannot be understood if first one does not learn to understand the language, to know the characters in which it is written. It is written in mathematical language and its characters are triangles, circles and other geometrical figures, without which it is impossible to understand even one word; without them it is like vainly going around in circles within a dark labyrinth."

Galilean science searches to explain natural phenomena by discovering the laws which regulate them. Their causation is a relationship between phenomena which disregards the knowledge about their meaning or their purpose. Certainly one has to suppose that those laws which rule nature do exist, but Galileo has seen how his admired Archimedes has used mathematics in order to understand certain problems in physics. In "On the Equilibrium of Planes" and in "On Floating Bodies" Archimedes obtains a set of results and propositions which follow an order inspired by the Euclidean deductive model, and Galileo himself has discovered, by putting movement into geometrical form, the laws of falling bodies. Now he has almost total confidence in his method: to explain a phenomenon of nature it is necessary to construct a mathematical theory, which will consist of definitions, axioms and theorems, and once the alleged law is obtained, it must be tested though experimentation. This Galilean combination of experimentation and mathematical abstraction will become the basis of all modern science.

Descartes, a first-rate philosopher, is nothing more than a secondary figure as a mathematician, according to the historians of mathematics. However, his influence on subsequent mathematics was immense, and with him a new mathematics begins, the mathematics of the scientific revolution and the modern age. Descartes breaks away from the modes and precepts of the Greeks' mathematics and he especially breaks away from the Aristotelian veto of infinity. Descartes lives in a convulsive era in which a closed world has passed into an infinite universe, in which certainties have disappeared and in which skepticism and doubt are the norm. In a kind of flight forward, Descartes is going to doubt everything, except mathematics, and God, that

guarantee him the veracity of clear and distinct reasoning which he achieves with his Method, whose conception is based on the mathematics of the Greeks.

In 1650 Rene Descartes dies, leaving an intellectual legacy of fundamental importance for the development of the new science. The Universe is now a complex framework governed by mechanical laws, and man, that finite and imperfect creature, yet endowed with a mind in which are sown the seeds of knowledge, can and must try to puzzle out and master those laws. The new scientist, conscious of living in an "infinite" universe in motion, radically different from the closed world of the ancients, will have to abandon the spirit of Greek mathematics. Now utility will prevail above aesthetics. Geometry will not have to fear "contamination" from the movement of the Mechanical; rigor, the maximum accomplishment which the Greeks required of themselves, will take on less importance. The "irrational number" will be accepted without having to resort to the cumbersome definition of Eudoxus's ratio of incommensurable magnitudes and the new scientist will have to dare to use infinite processes. Archimedean demonstrations will continue to be done, but avoiding the long and tedious method of exhaustion. All this because the ends justify the means. And the end is that of extracting the secrets out of Nature: "...*Knowing the force and the action of fire, of water, of air, of the stars, of the heavens and of all the other bodies which surround us...and becoming the masters and owners of Nature.*" In this manner, said Descartes, with study and work man will recuperate Paradise lost.

This message travels throughout all of cultured Europe and the "Discourse on the Method" will be the most read and most influential scientific-philosophical book of the second half of the 17th century. This message is received by Isaac Newton, who ever since extreme youth aspires to be a philosopher of nature. Newton is going to spend many hours conquering the reading difficulties enclosed in a book such as "La Geometrie" by Descartes, but he will draw two fundamental conclusions:

-To aspire to be a philosopher of nature, it is necessary to learn the art of mathematics, to skillfully manipulate the techniques of calculus, in a world that demands quantitative knowledge. Mathematics will be conceived of not as an end in itself, but rather at the service of Physics and the Philosophy of Nature.

-There is no problem which cannot be solved if we work with the proper method and with the necessary tenacity.

Following Cartesian guidelines, Newton becomes an expert in algebra and he will learn from Wallis, from his "Aritmetica infinitorum," to use infinite algorithms without fear and without rigor (quadratures, calculations of tangents, maxima and minima, indivisible arithmetic, infinitesimals). At 23 years of age, Newton retires to his property at Woolsthorpe and during the next two years (1665-66) he will undertake one of the most fertile works produced by the human mind. There infinitesimal calculus is engendered and there, too, is outlined one of the books which has most

decidedly influenced the history of science and progress: "Mathematical Principles of Natural Philosophy."

The powerful techniques of algebra, together with infinitesimal reasoning full of intuition even though lacking in rigor, bring about extraordinary advances in the new science, and thus the Newtonian Universe is a limpid and serene immensity, an infinite and homogeneous space. Now the natural order manifests itself in rules presided over by necessity; the territory of man, on the other hand, is governed by will-freedom and human activity no longer has to be determined according to the natural order but instead according to the human will, individual or general; Nature serves at most as a reference point for human activity.

Mathematics in European culture, the one which produces the eclosion of modern science, is a fortunate combination of Greek geometry and the new infinitesimal techniques (aided by the metaphysics which underlies Christianity) and algebra, that "magical" mathematics, widely developed in Chinese and Hindi cultures, which reaches Europe through the Arabs.

It is at the beginning of the 19th century when education becomes nationalized in the developed countries of Europe: France, England and Germany; and mathematics comes to be an obligatory discipline in all spheres of education. Why must a young English aristocrat, well endowed intellectually and destined to hold high administrative posts in the middle of the 19th century, study "The Elements" by Euclid? Undoubtedly, because of the formative value of that synthetic geometry, which will prepare the "best minds" in rigor and creativity.

Why does mathematics continue to have such an important role in the educational curriculum in all the developed countries today at the end of the second millennium? It is not easy to answer this question. Now we also live in a democracy which applies to everyone, unlike the elitist Greek democracy, and in which public education is a right and a duty for everyone. Science, which has reached incredible degrees of sophistication, has largely replaced Religion in the popular mythology, and mathematics, this language that for the majority is abstruse and unintelligible, seems to replace the collection of magic recipes and formulas with which the magician of the tribe used to try to gain favor with Nature's designs.

We have seen that Greek geometry is a product of human intellect in which creativity and beauty are founded, directly inspired by the order and symmetry present in Nature, the latter to be studied in a reverent and contemplative manner. Almost two thousand years later the young René Descartes will contemplate with admiration the rigor and mastery of those geometrical constructions by the "ancient ones," to such a point that he will reject the other disciplines he studies because he considers them confusing and lacking in rigor. But there is something he does not understand and that is the aesthetic character and lack of immediate practical use of these constructions. And now the objective of his geometry, Cartesian geometry, will be radically different: it will aim not to contemplate but rather to act, in order to dominate Nature and put it at the service of mankind. And now, in our postmodern society, what is the point, at present and in the immediate future, of research in mathematics? And above all, the

question which most concerns us here: Why and to what end mathematics in the education of the masses?

It is very difficult to convince a majority of high school students of the practical use of mathematics in the work life that awaits them. One way to do it could be that which I will call "**ecological**:" we live in a society "contaminated" by consumerism, the destruction of nature, overcrowding and irrationality.

If ecology presents itself to us today as the most likely candidate to be the religion of the future, it is because it addresses the immediate need to guard against the destruction of the world and the sublime illusion that a holistic life in harmony with Nature is possible; both factors point toward salvation, as emergency and dream. We will analyze a possible adaptation of the teaching of mathematics to the ecological demands of the present. Mass society and consumer society are interwoven phenomena: it is the development of the former which enables the rise of the latter. Like the other fundamental institutions in the contemporary western world, public education also does not escape this destiny. The democratic masses of students voraciously consume the growing amount of knowledge offered to them by the democratic masses of professors. Has the educational system taken care that those who consume the scholastic learning are not the privileged future members of the ruling elite but rather the offspring of the social masses? Do those students--or does society--need that increasingly specialized knowledge, or does it actually function as a selection mechanism, a fossilized mechanism which no longer performs its original function but which is perpetuated by the inertia of all the masses and all the bureaucracy?

When computers easily perform calculations which used to be exhausting, the objective and meaning of teaching mathematics cannot continue to be that of forming technicians, but rather it must aim toward a goal and a significance that is ethical: the rational formation of students through the development of their logical capacities, and aesthetic: appreciation of the formal beauty intrinsic to mathematics. Fighting against the consumerist wastefulness in mass society implies in teaching today a change in criteria concerning why one should be educated in certain subject matters, which implies a revision of the subject matters themselves.

The Aristotelian doctrine of the "golden mean" is commonly known, stating that all virtue entails a balance between an excess and a deficiency. One of the virtues of mathematics consists in the use of its teaching as a means of implementing rationality, owing to its axiomatic-deductive method, a virtue which continues to be necessary in the face of the proliferation of thought based on magic, religion, the occult, superstition, etc. It is worth noting that the desire to know everything, more alive in young people than in adults, makes our students prone to accepting any irrational explanation of those phenomena which science cannot explain. But as compensation, ever since the dawn of the modern era, with Descartes, mathematics has proposed the technical domination of the world and undoubtedly its prestige is due to the success of that undertaking. The belief in the possibility of "mathematizing" all of reality is something we continue to find throughout this century in famous scientists,

sociologists, psychologists, philosophers, etc. The reductionist urge to restrict rationality to "mathematization," that totalitarian wish to impose a model of reason upon everyone else, is the excess which diverts mathematics from virtue. Aristotle's doctrine, then, involves a way of teaching science while recognizing that it has limits, that not everything can be a subject for science, that not everything is "mathematizable," that science is always a plurality of open paths which intersect, and that it is irrational to think that there will be a future wherein science will have solved all human problems; science, like life, is always problematic.

Mathematics, as an acting force aligned with others in the complex scientific-technical framework, through which political-economic power exercises its domination over Nature, whose destruction has already reached more than alarming levels, will have to pay in the sight of present and future generations for its share of the blame in a vision of the world that requires abandonment. The recuperation of the Greek ideal of mathematical beauty, a beauty of forms applicable to inert nature and to living beings and their works, can be a valuable counterbalance and springboard for exploring the possible paths of a mathematics committed to an ecological and postmodern vision of human life in the limitless universe.

A key issue in all of the above concerns the preparation of the teachers. Our universities, affected by the "Harvard syndrome," produce specialists; and young graduates, the majority destined for teaching at the secondary level, are "ignorant technicians" in the best of cases. Orphaned of knowledge in Astronomy and Physics, they do not know Euclidean geometry, and for them Philosophy and Mathematics are disciplines whose intersection is null. It is not strange, then, that upon arriving at intermediate-level schools they behave like specialists. The cultivation of an interdisciplinary approach to learning strikes us as fundamental and necessary in order to break away from the "unculture of the specialist" so common to all of us, and we believe that this break can be accomplished better at the intermediate level of education than at the university, due to the "terminal specialization" characteristics of the latter. And it is possible: we are doing it in our "Orotava" Seminar on the History of Science, where for the past four years we have been bringing together teachings from mathematics, philosophy and the natural sciences, in a spirit of renewal which has already been fruitful.

Mathematics as education requires, above all, faithfulness to itself, which means abandoning a notion of science that is exclusively operational and instrumentalist, a notion which manifests itself, when it comes to its pedagogical transmission, in a culmination of calculations, formulas and algorithms, omitting from its teaching the reality of science; in other words, on one hand, the whole set of problems to which science has been responding, something that requires a knowledge of the history of science in order to regain a sense of its genesis and, on the other hand, the application that each scientific discovery has eventually had both inside and outside of science, which enables us to understand its usefulness and consequent conversion into one of the main forces in the transformation of the world and of life.

The mission of mathematics in secondary education is fundamentally that of cooperating, with the other disciplines of learning, to form certain capacities in the student which permit him to understand the complex world that surrounds him and to provide him with logical and methodological schemes, through which he can rationally follow argumentation. **We consider that today more than ever, the principal function of mathematics is in the formation of students and that it should be presented by means of History, in relation to Philosophy and Art, with Physics and Cosmology, as a living organism, in evolution and intimately linked to mankind's desire to understand reality.** The high school student at the end of this millennium needs a humanistic formation in this "technified" world, which gives him access to managing ideas through which he can assimilate the immense quantity of knowledge offered to him. **I propose a mathematics at the service of and as a pretext for Culture,** which might serve as a guide to the changes and occurrences during the long distance that Humanity has covered all the way up to our time.

I would like to end this exposition by making an invocation to Beauty. Speaking to high school students about the beauty of mathematics and the profound aesthetic impressions it is capable of producing, is generally taken as a provocation resulting in laughter. And yet, the History of Mathematics demonstrates that this has been the case since its beginnings in ancient Greece up to the present day. The great Portuguese poet of our century Fernando Pessoa likewise made this observation, and wished to express it in this brief poem:

"O binómio de Newton é tao belo, como a Venus de Milo.
O que á, é pouca gente para dar por isso"

Pessoa, a brilliant high school student, showed in this manner his admiration for the structural beauty which accompanies that algebraic development and at the same time he speaks to us of the difficulty of capturing it. This is because beauty cannot be imposed nor shown *per se*; it has to be discovered to be more appreciated. But just as in the children's game where someone has to guarantee the existence of the "treasure" in order to then begin looking for it, it is the mission of the mathematics teacher to announce or provide this unsuspected companion that is the beauty in mathematical constructions. We believe that it is a duty of mathematics teachers to recover the profound sense of Beauty in this magnificent construction of mankind which is Mathematics, and which cannot be presented as something abstruse, without meaning and without life.

José L. Montesinos Sirera
Seminario Orotava de Historia de la Ciencia
(Translated from Spanish to English by Linda Ribera)

panels
tables-rondes
painéis

Panel organizers were invited by the Programme Committee. In these proceedings we include the texts sent by the organizers and members of the panels.

Les organisateurs des tables-rondes ont été invités par le Comité du Programme. Dans les actes sont inclus les textes envoyés par les organisateurs et par les membres de chaque table-ronde.

Os organizadores dos painéis foram convidados pela Comissão do Programa. Foram incluídos nas actas os textos enviados pelos organizadores e pelos membros dos painéis.

Panels • Tables-rondes • Painéis

- Pan01: *History of Mathematics Education*
Organizer: Fulvia Furinguetti, Università di Genova, Italia
Members:
Charles V. Jones, Ball State University, USA
Gert Schubring, Universität Bielefeld, Germany
Harm Jan Smid, University of Delft, The Netherlands
Leo F. Rogers, Roehampton Institute, London, UK
Osamu Kôta, Rikkyo University, Japan University
- Pan02: *History, research and teaching of mathematics*
Organizer: Luis Radford, Université Laurentienne, Canada
Members:
Fulvia Furinghetti, Università di Genova, Italia
Guillermina Waldegg, Sec. Metodologia e Teoria de la Ciencia, CINVESTAV, México
Leo Rogers, Roehampton Institute, London, UK
Michael Otte, University of Bielefeld, Germany;
Rudolf Bkouche, IREM de Lille, France;
Victor Katz, University of the District of Columbia, U.S.A.
- Pan03: *Perils and Pleasures of the Internet*
Organizer: Jan van Maanen, University of Groningen, The Netherlands
Members:
Eleanor Robson, Oxford University, UK
Frederick Rickey, Bowling Green State University, USA
John Fauvel, The Open University, UK
- Pan04: *Mathematical Proof in History*
Organizers:
Jesus Hernandez, Universidad Autónoma de Madrid, Spain;
Victor Katz, University of the District of Columbia, USA
Members:
A. Durán, University of Seville, Spain
Evelyne Barbin, IREM Paris 7, France
Israel Kleiner, York University, Canada
Man-Keung Siu, University of Hong-Kong
Mariano Martinez, Universidad Complutense, Madrid, Spain

PANEL: HISTORY OF MATHEMATICS EDUCATION

Chief organizer: Fulvia Furinghetti, Dipartimento di Matematica dell'Università di Genova, Italy

It is widely recognized that mathematics has always played an important role in the global policy of education from the earliest times of the organization of the national education systems. In many modern states the professional mathematicians participated actively to the construction of curricula. Their contribution was not confined to propose mathematical contents, since they considered a wide range of elements: the teacher education, the production of textbooks, the teaching/learning problems and their link with psychology. This last point is specific to mathematics which is considered a privileged field for psychological research.

The interest of leading mathematicians for mathematics instruction is behind the major changes in mathematics curricula of the XX century: the 'Meran Syllabus' sponsored by Felix Klein and the 'modern mathematics' inspired by the French group Bourbaki. The entrance of computer in school is one of the few examples of changes in mathematics curricula coming from outside the mathematical environment.

Changes in mathematics curricula are originated by the fall-out of advances in mathematical research, and, more frequently, by the acknowledgement of the inadequacy of the current styles of teaching to the evolution of world outside school. History of Mathematics teaching shows that the efforts of the curriculum developers did not always attain a satisfactory outcome in school, since they met with the 'natural conservatism of the school world'. In this connection I quote a sentence by the Italian historian of mathematics Gino Loria which stigmatizes (with a bit of humour) the attitude of school towards changes: «second to funeral rituals, educational institutions are those most obstinately resisting innovators' efforts». There is not a single cause to this natural conservatism, but rather a concurrence of elements: teachers' attitude, publishers of textbooks, students' families, organization of instruction and school activities, assessment, evaluation, access to High school or to University, political influence in designing curricula, teacher education and re-training. All these are important issues to study in connection with history of mathematics education.

The nature itself of the discipline and the related problems of its teaching tend to amplify this conservatism and originates an issue characteristic of the history of mathematics education, the phenomenon of 'recurrence' of certain didactic problems. Examples of this recurrence may be the problem of proving (if and how), the duality intuitive/rigorous in the approach to a topic. The solutions proposed by the educators are different in the different periods and show traces of the social context as well as of some trends in mathematical research; also in the looking for solutions we find a recurrence. The paper (Swetz, 1995) offers examples showing that the practice to incorporate the use of concrete manipulatives and visual aids into the teaching is already present in Babylonian clay tablets and later on in Chinese texts. In the Italian

medieval manuals the different techniques for multiplication were represented as a chessboard, as a bell, as a cup, a little castel, ... The 'philosophy' underlying these different attempts to communicate mathematics is near to the one underlying the production and/or the use of didactic software. The conclusion of the author point out a specificity of mathematics in respect to other school subjects. He says (p.85): «many of the pedagogical techniques and principles that are favored today have experienced a long and diverse history. That history not only spans time but also cultures and testifies to the fact that while mathematics is universal, to a large extent, so is its pedagogy».

The point is that the evolution of mathematics has automatically implied a development of techniques for communicating it, giving origin to a parallel discipline, mathematics education. Such a deep concern in pedagogical problems is not present in other school subjects.

Another character specific to mathematics education, is the fact that in many countries the associations of mathematics teachers have a long and glorious history: they have fostered the rising of what we can call 'mathematics teacher identity'. Unfortunately often these associations are not politically influential and curriculum reforms are conceived without consulting them.

The way teachers accept reforms is another interesting issue to discuss. We have pointed out a certain conservatorism, but there are also examples of acceptance as it was in Italy the case of using the computer in secondary school (from age 14 onwards). In certain countries the mathematics programmes are quite prescriptive and detailed in content and/or methodology, thus leave a few space to the teacher's initiative and foster a certain passivity in applying the suggestions from the institutions.

We have outlined some general issues of the history of mathematics education. Each country presents specific problems. As an example of this we can mention the following problems intervening in the Italian history of mathematics education:

- the strong influence of the Euclidean geometry in the curricula until the 1950s
- the difficulty in accepting foreign innovations (Meran Syllabus, Bourbaki, ...)
- the difficulty in introducing analysis in the mathematics syllabus in XX Century
- rigorous versus empirical/intuitive approach to teaching
- the centralized system for the final examination in secondary school (age 19 years).

References

- Furinghetti, F.: 1994, 'Mathematics teachers and changes in curricula: problems of re-shaping beliefs and attitudes', in N. A. Malara & L. Rico (eds), *Proceedings of the 1st Italian-Spanish symposium in mathematics education*, Modena, 173-180.
- Swetz, F.: 1995, 'To know and to teach: mathematical pedagogy from a historical context', *Educational studies in mathematics*, v.29, 73-88.
- Wojciechowska, A.: 1989, 'Curriculum reform in mathematics: beyond the impossible revolution?', *Journal of curriculum studies*, 21, 151-159.

Problems of research on history of mathematics education

Gert Schubring, Universität Bielefeld

While mathematics history is a well established field of scholarly activity, history of mathematics education is a field which has found sustained interest only since a few years ago. In the interest of further progress, methodological reflection will be helpful in communicating the results of research. And given the growing cooperation on the European level, comparison between the different countries becomes essential, further enhancing the importance of methodological reflection. On the other hand, educational history used to be confined to national history, and it is thus a challenge to find the pivotal elements for a comparison.

The inherent methodological difficulties can be illustrated by another comparison with mathematics history: In the understanding of many of its practitioners, mathematics history can be largely exercised as an "internal" history, i.e. as a history of "ideas" - as investigations on the emergence and development of scientific concepts. To graft this kind of approach on the history of mathematics education would lead to insignificant results: changes in school knowledge are indicators of other processes so that registering the introduction and further utilization of certain concepts within school mathematics will only lead to surface data.

In fact, school knowledge is even less "neutral" than scientific knowledge: History of mathematics education must therefore be conceived of as a part of the social history of knowledge. School mathematics develops as a constitutive part of the institutional history of school in the respective country - it is subjected to social pressures on contents and methods of teaching, and its epistemology is affected by the social norms and values generally shared in a country at a given time.

A second methodological issue is given by the characteristic epistemological nature of mathematics which I should like to call its "double-face-nature": Mathematics belongs at the same time to the humanities and to the natural sciences. It follows immediately from this double character that mathematics education has to be analyzed historically at the crossroads of liberal education and of vocational training. Since every institutional system implies in general another function of mathematics within the educational system, this makes cross-national studies difficult.

With these methodological issues in mind, one can now outline several research dimensions which will reveal means for cross-cultural comparisons.

State of mathematics within general education for all:

There is a remarkable contradiction: Although mathematics has constituted one of the basic branches of instruction since the earliest times of institutionalized teaching (in ancient Egypt and Mesopotamia), mathematics was assigned a marginal role in medieval and pre-modern schooling. And even in modern times, when mathematics, during the nineteenth century, attained the position of a major subject in the systems of public education of most of the developed countries, this discipline, in the eyes of the greater public, retained the character of something accessible only to specially gifted people or of a craft restricted to vocational purposes.

Delimitations between secondary and higher education:

Contrary to our understanding of today, there were no systems of secondary education in pre-modern times. The emergence of a secondary school system and its differentiation from higher education, namely from the Faculty of Arts was a late and

complicated process and affected in particular mathematics teaching. The transition from the secondary to the tertiary level has always proved to be controversial regarding the delimitations of the respective knowledge to be taught. The modern system of schooling constitutes no institutional unity, but rather a hierarchy of institutions. Each type of institution incorporated a set of values of its own, according to the social functions of knowledge it taught. In agreement with these values, each institution used to mold a particular corpus of school knowledge, accompanied by particular methods and epistemologies. Particularly relevant was the delimitation between the knowledge domains for secondary schools and for universities. Characteristic is the opposition between the static and elementary nature of secondary school mathematics in the second half of the nineteenth century in Germany and the open and dynamic development of the mathematical studies in the universities.

The professional role of the mathematics teacher:

In order to counterbalance the traditional history of administrative decisions and in order to better approach school reality, the professional life of the mathematics teacher should be the focus for historical research. Since their professional activity is shaped by their personal view of and their relation to mathematics ("love of mathematics"), investigations into history of the mathematics teacher profession provide a privileged key to the reality of mathematics instruction; at the same time, they allow to establish the historical relation between school mathematics and the social dimensions of this knowledge. Investigating the modes of the teachers' formations, of their examinations, of their publications and epistemological convictions yields essential components for structural analyses.

The function of textbooks:

complements the analysis of the professional life of mathematics teachers. Within the traditional paradigm of concentrating on published texts, textbooks have played a prominent role. However, neither a systematic analysis of the production of textbooks in a given period has been undertaken, nor was there an analysis how textbook and teacher - the two main factors influencing the instructional process - interact with each other historically. Studies on France and Germany provide evidence that there is a dichotomy between improvement of teacher education and the elaboration of good textbooks: the two factors cannot be optimized simultaneously.

Relation between scientific knowledge and school knowledge

There is not just *one* source for new knowledge (say, in universities or academies) and it does not necessarily become school knowledge by a one-sided top-down-process. The *elementarization* of new knowledge to *teachable* knowledge is in itself a social process which is influenced by factors particular to each culture and state. School knowledge is, hence, not only shaped by institutional hierarchies, but also affected by cultural and social factors and constraints. These constraints used to be translated into epistemological conceptions. The teaching subjects in school syllabi of different countries are therefore not directly comparable; one has to take into account their context factors.

FORMATIVE VALUE OR SELECTION: THE RISE OF MATHEMATICS EDUCATION

H.J. Smid, University of Technology, Delft

Compulsory mathematics education started in The Netherlands in 1815. In a Royal Decree on higher education also some rules concerning the Latin schools were provided. The decree stated that after the daily lessons in Latin and Greek also modern and ancient history and geography, mythology and "the principles of mathematics" should be taught. The decree gave no further details about the content of the mathematics to be taught, nor about the amount of time to be spent on math. Furthermore, the decree gave no reasons for the obligation to teach mathematics, but from other documents around the same time it is likely that the government thought that the learning of some mathematics fitted in a more modern education and that mathematics had "formative value"; it learned young boys good thinking. The government certainly had not the intention that mathematics should become a major topic on the Latin schools, it was just something extra.

In the beginning there were considerable problems. Some schools were reluctant to teach mathematics, complaining that the learning of math spoiled children for the learning of Latin and Greek; mathematics was "the grave of a good taste". The teachers of Latin and Greek, who also - in the plans of the government - had to teach mathematics, often did not have the knowledge to do so. It was unclear what should be taught, for how many hours a week, and to what classes. In 1826 the government gave some brief indications what mathematics should be taught and from then on, the situation gradually became better. From about 1840, mathematics had become a major topic on the Latin schools. It was then taught in all classes, on average 4 hours a week, usually six year long. There were good books, which most of the schools were using. A more or less standard curriculum had emerged. The curriculum comprised:

- arithmetic; including proportion, logarithms and the decimal system,
- algebra; algebraic notations and the manipulations of formulas, extraction and calculations with roots, and equations,
- plane geometry, mainly the first books of Euclides.

Mathematics was then taught by specialized teachers. Surprisingly they usually had no university background, but most of them were teachers from elementary schools with special knowledge of mathematics. There remained one weakness: the government had no real effective way to control the level and quality of teaching and learning. Apart from the period 1845-1851 there was no central examen: each Latin school had the right to grant their pupils entrance to the universities.

There was another part of the educational system where mathematics began to play an important role: on the so-called "French schools". French schools had been established to give children an education for future jobs in trade and commerce. Until the beginning of the 19th century they mostly taught modern languages and book-keeping. Until 1863 there was no special legislation for these schools. So the content of their teaching was for themselves to decide and they responded to the educational market. In the course of the first half of the 19th century there was a growing demand in these

schools for mathematics education. For a part this demand had the same reasons as on the Latin schools: some math was thought to be suitable to a modern education, and quite some boys first went some years to a French school before they entered a Latin school. So these schools offered more or less the same math curriculum as the Latin schools.

Some of the French schools however did offer more: more algebra, trigonometry, solid geometry, some even descriptive geometry. There was a reason for this. In 1817 an admission examen was set up for the Military Academy. In the years before the program of that Academy was modernised and according to the modern principles mathematics played a major role in the curriculum. But the admission to the Academy was until 1817 not based on the knowledge of the future pupils, but more or less on family relations, protection, etc. That became unsatisfactory: too many pupils were unable to follow the modernised curriculum. So an admission examen was established. In the beginning the demands for mathematics were low, in the decades to follow they gradually became higher. But there was a more interesting aspects of these examens. The number of places available was limited, there were ususally more applicants. Now one could voluntarily take part in an auxilary examination in mathematics. Other things being equal, good results in these extra topics enhanced the chances to be admitted. So most pupils felt obliged to learn more mathematics than was formally necessary. In 1842 the Polytechnical School in Delft was established, to enter that school one had also to participate in an entrance examen. That gave another impulse to the schools training pupils -especially in math - for these kind of examens.

So in the first half of the 19th century we see in The Netherlands the rise of mathematics education, based on two motives. The first motive we can call a cultural one. A civilised person in the 19th century should, according to the standards set by The Enlightenment, know something about mathematics. In the way the government puts it: "According to the position that science has now in society, the learning of mathematics in Latin schools is necessary". This motive ususally was combined with the motive of the so-called "formative value": mathematics as good gymnastics for the brain. The second motive was that mathematics can be used as a means of selection. Now that is a motive that ususally goes silent. Most mathematics educators did not and still don't like to talk about this aspect of math teaching.

Nowadays mathematic teachers like to stress the usefulness of math in modern society, or talk about realistic math education. For them the idea of formative value of math has become obsolete, and the use of math as means of selection is something most of them preferre to ignore. I think the people outside the math profession think different. Most of them firmly believe in the formative value of mathematics, and most of them don't hesitate to use mathematics as a way to select what they think are are clever candidates for their jobs or schools. They agree that mathematics is useful for its own sake, but when you ask them what mathematics they need in their profession they often have no idea or they don't mind what math their future employees or students have done; as long as it's a lot and difficult mathematics. Mathematics education owes its dominant position still for a large part to the same motives that underlied its rise in the first half of the 19th century: its supposed formative value and its usefulness to select those who have shown they can perform something really difficult.

The Roots of the Curriculum: a Brief History of Mathematics Education in England

Leo Rogers, Roehampton Institute, London

This brief presentation will attempt to outline the principal social, economic and intellectual factors which have influenced the mathematics curriculum in England. There are two major areas which have developed since the beginning of the industrial revolution (1750), these are the separate strands of the public technical and professional education, and the education provided by the universities. At the beginning of this period, the three universities in England; Oxford, Cambridge and Durham provided a general classical education for the sons of the rich and those who wanted to enter the Church of England. A condition for entry to the university was the oath of allegiance to the King as head of the Church in England. However, the influence of reformists like Wesley and Knox meant that many people were not members of the Church of England and refused to take this oath.

The industrialists began to meet together in interest groups to discuss scientific and philosophical matters. They founded the 'Dissenting Academies' as places where they could establish an appropriate education and be free to worship as they wished. The academies developed original curricula; their purpose was to educate the sons of the leading industrialists and so they taught both academic and practical courses for example; mathematics, grammar, book keeping, geography, foreign languages, etc.

For a long time before this, private tuition in practical subjects had been available from a variety of 'mathematical practitioners'; instrument makers, surveyors, navigators, apprentice masters and others who had useful skills. At this time the academies also became the focus for the workers' self-education movements. Military and Naval academies also existed to train young men for the various commercial organisations like the East India Company, as well as for life in the army and navy.

By the beginning of the nineteenth century there was a well established organisation of public practical education supported by leading industrialists and charities. There were also Church Schools for the education of the poor. Later in the century saw the development of the Public Schools (Eton, Winchester, Charterhouse, etc) where the sons of the rich and the aristocracy could be prepared for life, or for entry to the universities in England or abroad.

The university curriculum did not begin to change until the early part of the nineteenth century where people like Babbage, Herschel and Peacock were responsible for introducing the Leibnizian notation for the calculus to Cambridge, and De Morgan became the first professor of mathematics at the newly founded secular University College of London, who was also involved in the popular education movement. From this time the two paths become distinct; the universities providing a classical academic education, and the Technical Institutes training for the rising middle classes and skilled workers.

The Great Exhibition in London of 1852 saw the foundation of what is now Imperial College and the Royal School of Mines by Prince Albert, giving official sanction to practical as well as academic training. By this time also, the Mathematical Tripos examination Cambridge university had been established which set the fashion for written final university examinations. Subsequently, entrance examinations were established by the universities. In the 1870's the government decided to formalise the situation by passing the first Education Act with compulsory full-time education for children. By the end of the nineteenth century we have separate education for academic and technical courses, and a system of examinations controlled by the universities. Also, the first professional association for teachers of mathematics was formed which later became the Mathematical Association. During the nineteenth century there was a strong revival in England, and both academic and practical (applied) mathematics reached a high standard.

In the twentieth century the Technical Institutes developed into Polytechnics which slowly widened their curricula in competition with the universities. Secondary education reflected the division with grammar schools training students for entrance to the universities and secondary schools providing mathematics for practical and technical training. Both school sectors were dominated by the requirements of the university entrance examinations which later became established as the 'Advanced Level' public examinations taken at the age of 18. In the 1960's many grammar and secondary schools were reorganised into 'comprehensive' schools, and more recently, many pupils attend a 'tertiary college' at the age of 16 for both academic technical and professional courses.

Up to about 1950, the school mathematics curriculum was dominated by the grammar schools and the requirements of the university entrance examinations which influenced the content of the textbooks. Children who were not destined for university or higher professional employment would be given a diet of practical arithmetic which still included many of the remnants of the nineteenth century training for clerks and shopkeepers. A group of teachers who were dissatisfied with this undemocratic situation set up the Association of Teachers of Mathematics which led the reforms in the school curriculum and was instrumental in introducing many new ideas in methodology and content. The period from about 1955 to about 1980 saw many innovations in curriculum development originating from teachers groups, supported by local administration and by Non Government Organisations. A great variety of textbooks were published, and many mathematics teaching schemes were established, linked to commercial publishing houses.

These 'bottom up' reforms have now been replaced by government edict and more recently, Government Agencies and the Examination Boards have taken on this role, and have produced a stratification for determining achievement in school mathematics by deliberate policies of exclusion which are socially and morally unjust.

A HISTORY OF MATHEMATICS EDUCATION IN JAPAN

Osamu Kôta, Rikkyo University (Professor Emeritus)

This is a brief summary of a history of mathematics education in secondary schools in Japan.

1. Modern educational system in Japan was instituted in 1872; since then, mathematics has been taught mainly in Western style.

Before that time, people in Japan studied traditional Japanese mathematics, which had been developed in Japan since the early seventeenth century based on Chinese mathematics. Most of them studied mathematics either as a useful knowledge for their daily life or as a tool for their occupations. There were also mathematicians who studied mathematics itself as an art; however, their main concern was skilful solving of complicated problems. In this way, mathematics was regarded as a tool or a skill. This view of mathematics is still observed.

The school system and the curriculum were established firmly by the end of the nineteenth century. The objectives of mathematics education were regarded as teaching pupils mathematical knowledge useful for their daily life and/or for their further studies and also a mental discipline. Algebra and Euclidean geometry were taught in the traditional way at middle schools, the literal translation of *chugakko*, which were boys' secondary schools for general education. Stress was laid on problem-solving; for, problem-solving was considered a mental discipline and preparation for entrance examinations to advanced schools.

2. The idea of reform in mathematics education, advocated by J.Perry, E.H.Moore and F.Klein, had been introduced into Japan early in this century. However, revision of the curriculum had not been undertaken until the thirties.

The national textbooks of arithmetic for elementary schools were renewed entirely since the first grade children of the school year 1935. The new ones were edited so as to develop mathematical thinking of school children through their various activities. Intuitive geometry and materials related to the concept of functions and graphs were treated extensively.

The syllabus of mathematics for middle schools was revised drastically in 1942. The new one was intended to develop students' mathematical thinking so as to meet the national demand of that time. Stress was laid on heuristic methods. Utility and applications of mathematics were emphasized. New topics were introduced: analytic geometry, nomography, descriptive geometry, probability and statistics, and the idea of differential and integral calculus. The syllabus also intended to get rid of Euclid. However, the syllabus was not carried out completely due to the World War II, and many ideas in the syllabus have disappeared from the secondary education after the War.

3. After the World War II, the educational system in Japan was reformed entirely. The new system came into operation in 1947. Compulsory education was extended to nine years; gender differences in school system and the curriculum were removed.

In elementary and lower secondary schools, mathematics was taught relating with

pupils' experiences in their daily life. This resulted in a decrease of mathematical contents in elementary and lower secondary education and a decline in pupils' achievements in mathematics. On the other hand, mathematics in upper secondary schools was taught systematically; algebra, geometry and elements of calculus were taught systematically.

The curricula of elementary and lower secondary schools were revised in 1958. Mathematics was revised to be taught systematically, and the level of mathematics in elementary schools was raised to that before the War.

4. Revisions of the curricula of mathematics in the sixties and seventies were intended to modernize mathematics education to cope with the development of mathematics, science and technology.

The curriculum of upper secondary schools was revised in 1960. The revision was intended to develop students' basic knowledge and skills and to improve scientific and technological education so as to meet the demands of the society. As to mathematics, calculus and analytic geometry were enriched, and new topics such as vectors and the concept of sets were introduced; on the other hand, Euclidean geometry by synthetic method was lightened, and, as a result, treatment of reasoning and proof was lightened.

The curricula of elementary, lower secondary, and upper secondary schools were revised after ten years, and the new ones were put into effect in the early seventies. Revision of the mathematics curriculum was influenced by the New Math movement. For instance, sets were introduced in the fourth grade of elementary schools.

Due to the introduction of new topics, Euclidean geometry, applications of mathematics, and topics related to other subjects were deleted or lightened. In this way, upper secondary mathematics leaned towards formal and abstract mathematics rather than applicable mathematics. Mathematics education was going in the direction opposite to the direction in which it had proceeded since the beginning of this century.

5. The curricula were revised after nine years. One of the aims of the revision was to lighten a heavy curriculum by restricting contents of each subject to basic ones. As a result, as to mathematics, examples and applications were treated lightly, and exercise problems in the textbooks were decreased in number. In this way, the revision could not change school mathematics to interesting and easy one.

The curricula were revised after twelve years. The revised curricula are the present ones. Revision of the curriculum of upper secondary schools is intended to cope with the students of diverse interests and abilities as a result of spread of upper secondary education and to meet the demands of the society.

6. Stress on students' acquisition of skills in addition to spread of upper secondary education have caused problems in mathematics education. Most students regard mathematics merely as a tool or skill; for them, to study mathematics is to learn techniques of routine problem-solving; many of them try to learn by rote with poor conceptual understanding; they have difficulty in mathematics and they dislike mathematics. Mathematics education in Japan should be improved to teach students mathematics of better quality and to meet the various demands and expectations of the society.

HISTORY, RESEARCH AND THE TEACHING OF MATHEMATICS

An Introduction for the Panel

Luis Radford, Université Laurentienne
Ontario, Canada.

One of the most frequent ways in which the history of mathematics (HM) has been used in the classroom consists of:

- (a) locating and extracting an "interesting" old mathematical episode and
- (b) presenting it to the students.

Although the specific aims may vary (e.g. the aim may be that of capturing the students' attention in order to introduce them to a new curricular topic), the general goal of using HM in a teaching context is obviously to *improve* learning.

One of the problems that has been recognized concerning the use of HM is that it requires teachers to know more than only the modern mathematical content to teach. Beyond the necessary mastering of the historical mathematical content related to the episode with which we want to deal in the classroom, there are, however, two *deep* methodological problems to be considered that we want to discuss in this panel.

The first methodological problem requires us to specify what we mean by an *interesting* old mathematical episode and the way in which we are going to *locate* and *extract* it. The second methodological problem concerns the way in which we are going to present the chosen old mathematical episode to the students, something that, I claim, cannot be done by merely dropping it off in the classroom. Indeed, there should be a very delicate and complex work of "adaptation" and "handling" of old mathematical "pieces" in order that history may become a genuine and fertile tool to improve teaching.

Of course, there is not just one possible solution to the two aforementioned methodological problems. However, any possible solution must take into

account (i) one's meaning of history and (ii) one's conception of the development of mathematical knowledge¹.

Often, the two aforementioned methodological problems have been avoided by assuming a simplistic and naïve view to points (i) and (ii) –leading to what we may call a Simple Teaching Model (STM). From a STM perspective, the history is confined to a sequence of events that follows a chronological order, whereas the development of the mathematical knowledge is underlined by a rather implicit standpoint according to which ancient mathematical ideas are but *imperfect* modern mathematical ideas.

Let me mention the well-known controversial "Euclidean Greek Algebra". Book 2 of Euclid's *Elements* has been seen, quite often, as a book that deals with quadratic equations. According to this view, if one does not *see* quadratic equations in Euclid's work it is merely because there were not any algebraic symbols at the time. From this interpretation, the "spirit" of Book 2 and Euclid's intentions are essentially considered as *algebraics*. However, a closer look shows that there is no such (modern) algebraic intentionality in the *Elements* (see Unguru, 1975). On the other hand, Høyrup's reconstruction of Babylonian mathematics suggests that the problems and methods that we find in Book 2 of Euclid's *Elements* are related to ancient techniques practiced by Babylonian scribes (see Høyrup, 1990). Of course, the ancient techniques were not taken over and kept intact by the Greeks. Ancient Near-East and Greek styles of mathematical thinking were very different. As Crombie said (1995), any style of thinking is determined by commitments to conceptions about nature and to conceptions about science. Hence, in order to be inserted in the realm of Greek mathematics, the pre-Greek methods had to undergo fundamental changes.

Thus, a STM avoids the aforementioned first and second methodological problems by assuming that mathematical knowledge is essentially unhistorical (which is somewhat paradoxical when we are speaking precisely about the History of Mathematics!). This allows one to link, without any problem, the concepts of modern school mathematics to their ancestors –for, supposedly,

¹ Two of the most important current non-naïve research programs used in educational mathematical circles are the *Epistemological Obstacles* and the *Reification Processes*. Both present us different accounts of the growth of knowledge. This lead them to two different *readings* of the history; a data that is *interesting* for the first may not be interesting for the second and vice-versa (see Radford, 1996).

"adding" to the latter our modern notations makes them attain the level of "perfection" of the modern concepts. From this simplistic point of view, the only problem is how to disguise ancient and old conceptualizations in modern robes. However, doing so, we evacuate all the conceptions, intentionalities and *raison d'être* of past mathematics: we focus our attention on what we may call the "pure" mathematical knowledge. The question is: does such a thing exist?

Some modern historiographical trends have been considering the problem of mathematical knowledge in a broader perspective and are challenging the "internalist" approach that consists in seeing mathematics as a socioculturally-free activity. Within this new perspective, a "piece" of old mathematics cannot be reduced to its mathematical content. Mathematical knowledge cannot, unlike flowers, be extracted from its own habitat and put into vases.

In this case, the link between the HM and the teaching of mathematics becomes really *problematic*. Indeed, if (modern and past) mathematical styles of thinking are rooted in their own sociocultural contexts, is it possible for us to understand them?² However, if past mathematical styles of thinking are understandable, *how* can we understand them and to what extent? This is the profound challenge to the first methodological problem. In this panel, we want to discuss some characteristics of *frameworks* and *methodologies* that may make it possible to understand historical mathematical achievements and the way to interpret them, bearing in mind that our work should be done for *teaching purposes*. To have a chance to succeed in such an enterprise, we must specify some philosophical and epistemological viewpoints about human cognition and the development of mathematical knowledge (something that a STM overlooks –if not, ignores completely!).

We also want to examine, in this panel, some implications related to the second methodological problem. If, once again, mathematical styles of thinking are rooted in their sociocultural factors, is it possible to compare past and modern mathematical intellectual developments? It is clear that the sociocultural factors are not the same throughout time. Thus, *what* can be

² In order to better understand this question, it would be worthwhile to remember, at this point of our discussion, that Oswald Spengler suggested that different cultures are incommensurable (see Restivo, 1992, pp. 3-9). Of course, we may not agree with Spengler's view, but we cannot ignore it either!

compared? On the other hand, how can we "adapt" past achievements in order to improve learning in the classroom? One may now realize why I previously said that it is no longer possible to "denaturalize" the history of mathematics and to simply extract episodes and drop them off in the classroom.

To go a step further in the use of the HM in the classroom requires us to reflect upon and to discuss very seriously the foundations of didactico-historical approaches. This panel aims to contribute to the search of solutions to these problems by gathering different scholars with different experiences and backgrounds. We hope that the discussion will allow us to elucidate some paths to overcome the difficulties which a serious use of the HM in the classroom is now facing.

Acknowledgements

I want to thank the participants of this panel for having accepted to participate in it, and for sharing their expertises and points of view. They are, in alphabetical order, professors Rudolf Bkouche (IREM de Lille, France), Michael Otte (Universitaet Bielefeld, Germany), Fulvia Furinghetti (Università di Genova, Italy), Victor Katz (University of the District of Columbia, U.S.A), Leo Rogers (Roehampton Institute, UK) and Guillermina Waldegg (Centro de Investigaciones y Estudios Avanzados del Instituto Politécnico Nacional de México).

References:

- Crombie, A. C. (1995) Commitments and Styles of European Scientific Thinking, *History of Sciences*, Vol. 33, pp. 225-238.
- Høyrup, J. (1990) Algebra and Naive Geometry. An Investigation of Some Basic Aspects of Old Babylonian Mathematical Thought, *Altorientalische Forschungen*, 17, 27-69, 262-354.
- Radford, L. (1996) Linking Psychology and Epistemology: Can the history of mathematics be a useful tool for teaching mathematics ? *Proceedings of the 21st Meeting of the Canadian Society for the History and Philosophy of Mathematics* (in print).
- Restivo, S. (1992) *Mathematics in Society and History, Sociological Inquiries*, Dordrecht/ Boston/ London: Kluwer Academic Publishers.
- Unguru, S. (1975) On the Need to Rewrite the History of Greek Mathematics, *Archive for the History of Exact Sciences*, Vol. 15, pp. 67-114.

HISTORY, RESEARCH AND TEACHING MATHEMATICS: CASE STUDIES FOR LINKING DIFFERENT DOMAINS

Fulvia Furinghetti, Dipartimento di Matematica dell'Università di Genova, Italy

In the discussion about the use of history in teaching mathematics we find different characters: researchers in history, researchers in education, teachers, students. The role of historians would be mainly of interpreting and mediating sources; some of them who are sensible of pedagogical problems point out specific situations suitable to a didactic transposition. Sometime the position of historians seems a bit 'integralist' and their intention to be 'politically correct' with regard to history is perceived by the world of education as a hidden warning to keep away from history. On the other hand it is true that in some cases the world of educators felt into the pitfall already met in the early attempts of introducing the computer in mathematics teaching: history and the computer are both appealing and appear good solutions of the problem of involving students in mathematics, thus the transposition in classroom was carried out mainly relying on the glamour and neglecting a careful set up of methodologies and objectives. Moreover the teacher training in history was often an underestimated issue (see the panel on this subject in the Proceedings of 1993 Summer University in Montpellier) and left to the teacher's autonomous initiative.

To outline a theoretical framework to the use of history in mathematics teaching it is useful to look at the past experiences, some of which are very good. As a general trend we can observe that:

- behind the work in classroom there are a great enthusiasm of the teachers involved and their reliance in history
- the teachers' education and training in history of mathematics is not homogeneous: someone has approached original sources and research papers, others use manuals of 'history of mathematics, popularization books
- after having introduced history in classroom the feeling is that the experience was positive. This opinion, which can be shared in the majority of cases, usually comes from impressions and not from regular and systemic studies on the outputs
- each experience is a 'microworld', that is to say the various experiences are quite scattered and there is not an organized net of classes and teachers carrying out analogous experience. This does not allow to compare the different results and to establish a trend of research.

The last two points deserve reflections since the development of the use of history in mathematics teaching - on the efficacy of which we trust - needs of a systemic approach as happens in other fields of mathematics education. In this concern our contribution here is to offer insights on teachers' and students' behaviours with the following case studies.

Teacher A: The teacher presents topics of history of mathematics through research performed by the students (aged 18) themselves under his guidance. The sources are manuals of history of mathematics, encyclopedias, ... The declared objectives are: - to set mathematics in a general cultural framework, - to stress the cultural value of mathematics versus the aspect of a collection of techniques, - to offer motivations to students not loving the scientific disciplines, - to have a general picture of fundamental ideas of mathematics.

Teacher B: The teacher is doing research on arithmetics texts of XVI century and uses them in classroom (ages 10 to 11). Here there are some sentences she told for supporting her choices. «When a colleague ask me if and how to use history I answer: Do not talk about the history of mathematics in your classroom, but do it, use it!! Use historical problems in your teaching for reasons of variation and to give your pupils something extra! The extra given by historical problems to your pupils can consist on historical insights and mathematical insights. The historical problems may intervene at the end of the learning process as an extra exercise or application of a new learnt mathematical topic, or at the beginning to stimulate pupils to work with their own individual strategies».

Teacher C: The teacher has a good knowledge on history of mathematics as well as on original sources. She teaches at secondary level (ages 16 to 19). An example of her use of history is the application of the methods of analysis and synthesis to the proof. Students study some passages of Marino Ghetaldi's *De resolutione et compositione mathematica libri quinque* (Rome, 1630) where these methods appear in a very clear and systematic way. In this treatise the schematization of proof is effective from the pedagogical point of view and students apply quite naturally it to other situations such as the proof in geometry or calculus, even when the teacher does not ask it. According to the teacher this is the 'politically correct' position towards students: many proofs in history are born following this double road, while usually in school only one way is presented.

Teacher C: The teacher has a good knowledge on history of mathematics as well as on original sources. He introduces conics to voluntary students (age 17), outside the regular school time. The focus is on the French text *Traité des sections coniques, et autres courbes anciennes* by M. de la Chapelle (Paris, 1765), but often the discussion is widened to other aspects of culture. The interesting issue of this experience is in the regular check kept by the teacher on the students' reactions through written tests, interviews.

To hear the voices of the most important characters - the students - is a fruitful way to tackle the problem. This was suggested to me also by a student who felt uncomfortable when attending the first year course of Algebra in University. Asking for help he wrote in a letter that history may be an answer to his awkwardness: he thought that to know why ideas were born, which problems are behind this birth, in which order the ideas appeared would help to cope with concepts.

LES QUESTIONS DE L'HISTOIRE DANS LA RECHERCHE EN DIDACTIQUE: ÉLÉMENTS MÉTHODOLOGIQUES¹

Guillermina Waldegg, Centro de Investigación y de Estudios Avanzados

Introduction

Quand on s'approche des recherches en didactique qui ont été abordées dès la perspective de l'histoire, on a l'impression qu'il y a trop de techniques différentes pour traiter le sujet. Il semble aussi que les différentes optiques sont, en général, assez locales, assez restreintes et, peut-être, trop écartées les unes des autres. Le but de mon exposé est de présenter un examen succinct de la façon dont les questions de l'histoire entrent dans la recherche en didactique et de comparer les études les plus remarquables dans ce genre.

Méthode et méthodologie. Point de départ

Je commencerai par préciser la signification de quelques concepts utilisés dans mon analyse. D'abord, convenons d'un sens étendu du terme méthodologie. La *méthodologie* comporte:

- a) la méthode ou les procédés de la recherche, à savoir, un certain ordre d'action exprimé par l'ensemble de règles -- explicites ou sous-entendues -- qu'on doit observer afin d'arriver à des assertions sur le problème en question, et
- b) la façon de sanctionner les résultats, moyennant l'examen de leur correspondance avec les données "réelles" et de la cohérence logique de l'explication par rapport aux interprétations de phénomènes proches.

La partie des procédés ainsi que la normative sont déterminées par le cadre théorique à partir duquel on commence l'enquête. On entend par *cadre théorique* l'ensemble de théories et de conceptualisations, disciplinaires et épistémologiques, qui permettent au chercheur d'établir ses hypothèses et de réaliser ses inférences. Le cadre théorique détermine aussi (a) quels sont les "observables" dans la situation à étudier, (b) comment faire l'interprétation des observables, et (c) comment valider une telle interprétation. Il est clair donc qu'il n'y a pas de "méthode scientifique" unique pour réaliser la recherche, mais autant de méthodologies que de cadres théoriques.

La recherche en didactique est une discipline empirique, dans ce sens qu'on doit extraire les données de la "réalité" et les comparer aux hypothèses; le *laboratoire* de la recherche en didactique est donc le cabinet de travail, ou la salle de cours, ou l'école, ou la société ou, enfin, l'histoire; un tel laboratoire est l'endroit où l'on ramasse les données et où l'on met à l'épreuve les hypothèses. Les hypothèses seront d'autant plus puissantes que les instances pour les vérifier sont variées.

¹ Participation dans le panel: "Histoire, recherche et enseignement des mathématiques" (Luis Radford, organisateur)

Le pont vers la didactique

On a affirmé que l'histoire est, dans notre cas, le laboratoire où les hypothèses sont mises à l'épreuve et où les données sont recueillies. Cependant, l'élection des données qui fournissent le support empirique à l'étude est déterminée par des objectifs didactiques posés à partir des questions liées à l'apprentissage ou à l'enseignement; la délimitation des variables qui seront privilégiées ou mises en relief dans l'étude, dépend des problèmes identifiés dans la salle de cours.

Comment définir alors des objectifs de l'enquête, cohérents avec les données disponibles dans l'histoire? Quelle est la méthode pour délimiter les variables didactiques significatives dans ce cas-là? Enfin, comment vérifier les hypothèses didactiques sur le terrain de l'histoire? À mon avis, le seul moyen d'associer les problèmes de l'apprentissage et de l'enseignement aux données historiques est de faire appel au travail épistémologique. Les questions qu'on pose à l'histoire sont des questions essentiellement épistémologiques puisqu'elles surgissent, dans la salle de classes, dans des situations d'appréhension de concepts et de constructions de savoirs. D'autre part, la traduction épistémologique du développement historique est nécessaire et indispensable pour que les concepts prennent une signification didactique et que l'on puisse retourner dans la salle de classes pour tester à nouveau les hypothèses.

L'épistémologie est le pont obligé entre l'histoire et le travail en didactique mais, quelle genre d'histoire? L'histoire comme anecdote, comme un récit des faits du passé ou comme une chronique à valeur limitée dans la recherche en didactique qui s'intéresse aux aspects cognitifs. Cette facette de l'histoire est liée, avant tout, à la motivation dans la salle de cours qui, sans diminuer son importance, n'est pas au coeur des études cognitives. Il est important de montrer aux élèves que la science est une tâche humaine, qu'on peut rater, qu'on peut faire de bêtises; pourtant cela nous donne peu d'information sur les processus d'apprentissage. C'est alors l'histoire comme un "laboratoire épistémologique" qui nous intéresse. Une histoire que nous pouvons interroger à propos des conditions de la construction du savoir, de la transformation des notions, de l'évolution de l'ontologie des objets mathématiques, du rapport entre connaissance et réalité au cours du temps. À partir de ces questions - questions épistémologiques - nous pourrions décider s'il est utile d'essayer de transposer ces caractéristiques de la connaissance et de l'activité mathématique à la salle de classes étant donné les conditions d'une telle transposition. Une transposition qui prend en compte les différentes difficultés d'ordre cognitif, émotif, sociaux, institutionnel, etc. auxquelles est contraint l'enseignement et l'apprentissage des mathématiques.

Les différentes études

Un exposé comme celle-ci est inévitablement borné. Néanmoins à travers quelques exemples, je vais essayer de montrer de différentes approches dans lesquelles l'histoire intervient de plusieurs façons dans les études en didactique. Ils sont à mon avis, les plus représentatifs de ce courant et, il me semble, les plus clairs à montrer le rôle de l'épistémologie comme le centre du projet didactique.

1. Les obstacles épistémologiques

D'abord, nous avons les obstacles épistémologiques. La transposition dans l'enseignement mathématique de la notion de Bachelard² a été possible et même nécessaire grâce au développement de la théorie des obstacles didactiques de Brousseau³. Un obstacle épistémologique est une forme ou principe de connaissance qui, effectivement et sur un domaine étendu de validité, est capable de s'établir et de se fortifier pendant le développement d'une notion; mais qui, à une certaine étape, devient un facteur de blocage et, généralement, une source d'erreur importante et persistante. Un obstacle de ce genre continue à se présenter d'une façon récurrente bien qu'on le croit déraciné.

L'hypothèse sous-jacente de l'approche des obstacles didactiques établie sur l'idée de Bachelard soutient, d'abord, qu'un tel obstacle existe. Ensuite, que bien qu'il y ait des différences entre le développement historique du concept et son apprentissage à l'école, l'enseignement ne lui échappe pas complètement. C'est un passage obligé sur le chemin vers la connaissance puisqu'il en fait partie. Il s'agit dans cette approche (voici la méthode) d'identifier les obstacles dans l'histoire, de les caractériser comme des obstacles didactiques et de produire des modèles didactiques de situations qui prennent en compte toutes les conditions pertinentes de la construction des savoirs - connues dans l'histoire - et de les organiser selon leur propre logique.

Nous connaissons beaucoup d'études qui ont été réalisées suivant cette approche. Notamment, les études initiales de Brousseau exploraient cette notion dans l'examen des conceptions des élèves et de leurs erreurs persistantes à propos de l'extension du corps des nombres aux fractions et aux décimaux. Dans l'analyse, l'idée a été développée autour des notions de limite et d'infini par Cornu⁴ et par Sierpiska⁵ qui ont produit des résultats qui supportent les hypothèses sous-jacentes.

2. Les mécanismes de passage

Un deuxième style de voir l'histoire dans la recherche en didactique est celui qui part de la croyance que le développement d'une notion traverse quelques étapes bien définies; le but des études d'histoire dans ce cas est d'identifier ces étapes et de trouver les mécanismes de passage d'une étape à la suivante. Après cette identification, on constate leur existence dans la population d'étudiants. L'hypothèse sous-jacente de cette approche énonce que les étudiants traversent aussi des étapes similaires dans leur développement intellectuel et surtout, que les mécanismes de passage sont analogues à ceux de l'histoire. Si on connaît les facteurs qui contribuent à

² Bachelard, G. (1938) *La formation de l'esprit scientifique*, Vrin, Paris

³ Brousseau, G. (1983): "Les obstacles épistémologiques et les problèmes en mathématiques", *Recherches en Didactiques des Mathématiques*, Vol 4.2, p. 164-198

⁴ Cornu, B. (1991): "Limits", D. Tall (Ed) *Advanced Mathematical Thinking*, pages 153-166, Kluwer Academic Publisher.

⁵ Sierpiska, A. (1985): Obstacles épistémologiques relatifs à la notion de limite, *Recherche en Didactique des Mathématiques*, Vol. 6.1 pages 5-67.

surmonter une étape, on peut essayer d'élaborer des modèles didactiques capables d'aider les étudiants à les surmonter aussi. Personnellement, j'ai travaillé dans cette tendance sur la notion de nombre de Stevin⁶ et avec L. Moreno, sur les ensembles infinis en identifiant dans les travaux de Bolzano et Cantor les étapes du développement du concept d'ensemble infini et en vérifiant son existence dans des populations d'étudiants⁷. Anna Sfard vient de publier aussi une étude sur l'algèbre dans laquelle elle définit trois étapes suivies par le développement historique aussi bien que l'individuel⁸.

3. La transposition didactique

La troisième approche est celle de la transposition didactique. Les études sur la transposition didactique introduites par Chevallard⁹ visent à comprendre le cours de l'enseignement actuel, en étudiant dans l'histoire l'évolution des liaisons entre l'école et la science. M. Artigue a travaillé dans cette direction à propos des procédés du calcul différentiel et intégral pour comprendre les différences entre les conceptions de l'enseignant et la pratique en mathématique et physique. En plus, elle a travaillé sur les équations différentielles¹⁰ pour connaître la façon dont l'enseignant d'aujourd'hui utilise les méthodes de solutions d'équations de l'algèbre typiques au XVIIIe siècle.

L'hypothèse qui supporte cette approche affirme qu'il s'agit de rapports entre deux types de connaissances (formelle et scolaire) plutôt que d'obstacles ou de mécanismes de passage qu'on rencontre, de part et d'autre, dans l'histoire et dans développement intellectuel de l'étudiant.

4. Le statut des objets mathématiques

Finalement dans ce bref parcours, c'est le tour des recherches qui essayent de tester certaines catégories théoriques dans les cours de l'histoire et dans l'évolution de la pensée scientifique des élèves. Ce sont les études relatives aux différents statuts des objets mathématiques, notamment, la recherche de Douady¹¹ sur les nombres complexes où elle distingue deux façons de comprendre les concepts mathématiques, à savoir, comme des "outils" et comme des "objets". Dans le premier cas (comme un

⁶ Waldegg, G. (1993): "La notion du nombre avant l'établissement de la science analytique", *Actes de la Première Université d'Été Européenne: Histoire et Épistémologie dans l'Éducation Mathématique*, IREM de Montpellier

⁷ Moreno, L. and G. Waldegg (1991): "The Conceptual Evolution of Actual Mathematical Infinity", *Educational Studies in Mathematics*, 22, 1991, pp. 211-231

⁸ Sfard, A. (1995): "The Development of Algebra: Confronting Historical and Psychological Perspectives", *Journal of Mathematical Behavior* 14, 15-39

⁹ Chevallard, Y. (1985) *La transposition didactique- Du savoir savant au savoir enseigné*. La Pensée Sauvage, Grenoble

¹⁰ Artigue, M. (1989): "Une recherche d'ingénierie didactique sur l'enseignement des équations différentielles en premier cycle universitaire", *Actes du Séminaire de Didactique des Mathématiques et d'Informatique de Grenoble*, pages 183-209, Ed. IMAG, Grenoble

¹¹ Douady, R. (1984): *Jeux de cadres et dialectique outil/objet*, Thèse d'État, Université Paris 7

outil), l'intérêt est dirigé vers l'usage du concept afin de résoudre un certain problème dans un contexte spécifique, par quelqu'un de bien précis et dans un moment donné de l'histoire. Dans le deuxième cas (comme un objet), le concept est considéré dans une dimension culturelle, comme une pièce de la connaissance universelle, indépendant du contexte et des personnes.

Dans la même ligne, la thèse d'Anna Sfard¹² offre deux conceptions possibles d'une notion mathématique: la conception opérationnelle et la conception structurelle. Ces deux conceptions sont, d'après Sfard, complémentaires et duales. Elle montre que la face opérationnelle précède dans l'histoire la face structurelle.

La distinction postulée par Sfard, est un peu différente de celle de Douady, avec quelques coïncidences cependant: Sfard part de la posture épistémologique qui analyse la connaissance en termes de processus cognitive, tandis que Douady le fait en termes de domaine conceptuel et des problèmes, avec une importante référence à l'institution mathématique. Les deux positions épistémologiques sont légitimes mais elles ne peuvent pas être réduites l'une à l'autre. Il est nécessaire de souligner, néanmoins, que les deux approches permettent de s'interroger à propos des habitudes des enseignants consistant à introduire les aspects structurels des concepts mathématiques avant les aspects opérationnels, contrairement à l'histoire.

Conclusions

En guise de conclusion, je veux souligner que si on peut parler d'une méthode ou d'une méthodologie attachée à la recherche en didactique, elle consiste à interroger aussi bien l'histoire que les situations scolaires, moyennant des questions concernant l'épistémologie. En fait, je dirais que les études de l'histoire dirigées vers la recherche en didactique que je viens d'analyser brièvement partagent, explicite ou tacitement, les hypothèses des épistémologies constructivistes. Il est assez difficile d'imaginer une telle approche menée par un partisan de l'empirisme logique, ou d'une vision aprioriste de la connaissance. Il y a, avant tout, la conviction de l'existence d'une évolution des savoirs, d'un développement de l'intelligence des étudiants et des certains rapports entre eux, ce qui légitime les études de ce genre.

Finalement, si le contenu épistémologique du cadre théorique de la recherche détermine la méthodologie, et elle est indispensable pour établir la liaison entre l'histoire et la didactique, on peut donc assurer que cette méthodologie sera d'autant plus consistante que la théorie épistémologique qui la supporte est plus solide et plus cohérente.

Gómez Fariás 74, Coyoacán
04100, México, D.F.
México

e-mail: gwaldega@mailer.main.conacyt.mx

¹² Sfard, A (1991): "On the Dual Nature of Mathematical Conceptions: Reflections on Processes and Objects as Different Sides of the Same Coin", *Educational Studies in Mathematics*, Vol. 22-1, pp. 1-36

Epistémologie, Histoire des Mathématiques et Enseignement

rudolf bkouche
irem de lille

*"Ce qui est objet d'enseignement n'a que la force
que lui prête celui qui est enseigné"*¹

Francisco Sanchez, *Il n'est Science de Rien*

L'enseignement des mathématiques est chose difficile, on l'oublie trop souvent.

Depuis l'échec de la réforme des *mathématiques modernes*, réforme dont on avait espéré qu'elle permettrait l'accès des mathématiques à tous, on se retrouve quelque peu démuni lorsqu'on cherche les moyens de rendre enfin cet enseignement accessible au plus grand nombre². Devant cet échec d'un enseignement des mathématiques pour tous, de nombreux travaux se sont efforcés, à travers de multiples approches, de définir des démarches pédagogiques permettant d'assurer, de la meilleure façon possible, cet enseignement des mathématiques pour tous qui apparaît comme un point essentiel de la démocratisation de l'enseignement³.

Parmi ces approches, je m'intéresserai essentiellement au courant défini par "*une perspective historique dans l'enseignement des mathématiques*", courant qui s'est développé autour de la Commission Inter-IREM Epistémologie⁴. Ces travaux ont le mérite de mettre l'accent sur les problématiques qui ont conduit, au cours de l'histoire, à développer une activité mathématique, posant ainsi la question de l'apport de la connaissance de l'histoire des mathématiques à la pratique enseignante. Comme souvent dans ce type de travaux, au carrefour de la militance et de la scientificité, un enthousiasme justifié a conduit à un certain état d'esprit de prosélytisme, prosélytisme nécessaire dans la mesure où il a permis à des enseignants de s'intéresser aux aspects historiques de la discipline qu'ils enseignent, c'est-à-dire de la façon dont elle s'est construite et développée jusqu'à son état actuel, mais prosélytisme dangereux lorsqu'il conduit à chercher dans l'histoire des mathématiques et dans la réflexion épistémologique qui l'accompagne les conditions qui devraient enfin permettre de réussir l'enseignement des mathématiques⁵.

La question n'est pas de convaincre les enseignants de mathématiques que l'introduction d'une perspective historique leur apportera le salut: il s'agit plutôt d'explicitier, dans la mesure du possible, les raisons qui peuvent conduire à mener une réflexion d'ordre épistémologique dans le cadre du métier d'enseignant. Qu'une telle réflexion amène à s'intéresser à l'histoire des mathématiques, voire à y chercher les conditions d'un meilleur exercice du métier d'enseignant nous importe peu ici, ce que nous voulons développer, c'est comment une réflexion d'ordre épistémologique participe de l'exercice même du métier.⁶

L'objet de cet exposé est donc moins de définir *a priori* la part de l'histoire et de l'épistémologie dans l'enseignement que de tenter de cerner les lieux où l'enseignant rencontre, dans le cadre de la pratique de son métier, des problèmes d'ordre épistémologique⁷. C'est dans la mesure où la réflexion d'ordre épistémologique s'inscrit dans les problèmes d'enseignement que celle-ci peut prendre sens dans la pratique du métier; cela ne signifie pas qu'un enseignant ne puisse avoir une réflexion épistémologique propre (c'est-à-dire indépendante de tout problème d'enseignement) et c'est l'affaire de chacun de s'y intéresser ou non⁸.

Si l'on veut éviter le volontarisme et le prosélytisme dont j'ai parlé ci-dessus, il est nécessaire de pointer, autant que cela se peut, les lieux où l'activité d'enseignement rencontre des questions d'ordre épistémologique. Nous citerons ici deux de ces lieux, d'abord *l'idéal de simplicité*⁹, qui anime toute activité mathématique, sinon toute activité scientifique, ensuite *la question de la démonstration*, laquelle est au cœur de toute activité mathématique quelque peu consistante.

C'est à travers ces deux points que sont l'idéal de simplicité des mathématiques et la question de la démonstration que nous essayerons d'explicitier comment se situent, dans l'enseignement, les aspects épistémologiques de la discipline. Il y a évidemment d'autres points de l'enseignement des mathématiques qui demandent une réflexion épistémologique que nous ne pouvons aborder ici. Notre choix n'est cependant pas neutre; d'une part on sait combien la démonstration apparaît redoutable aux élèves, ce qui implique de la part des enseignants une réflexion sur la démonstration en tant que telle, réflexion sans laquelle la démonstration risque de n'apparaître que comme le simple usage de quelques règles et procédures définies *a priori* comme nous y invitent aujourd'hui les diverses boîtes à outils, référentiels et autres calembredaines à la mode; d'autre part on oublie trop que la science, comme toute activité rationnelle, s'inscrit dans un idéal de simplicité, que c'est cette simplicité qui constitue la valeur de la science comme l'un des lieux privilégiés de l'intelligibilité du monde, mais que cette simplicité, loin d'être donnée, est une construction lente, un objectif souvent difficile à atteindre, et que, en fin de compte, c'est cette simplicité qui conduit à accepter le prix à payer pour l'atteindre.

A partir de ces réflexions sur l'idéal de simplicité et sur les enjeux de la démonstration, nous pouvons revenir sur le rôle que peut jouer la réflexion épistémologique de l'enseignant (ou du futur enseignant) dans l'activité enseignante. Cela pose évidemment la question de la place de l'épistémologie et de l'histoire des sciences dans la formation des maîtres?

Cela dit, si j'emploie l'expression "réflexion épistémologique", c'est pour la distinguer de l'épistémologie en tant que telle. Nous distinguerons ici la réflexion épistémologique comme *constituante* d'une pensée et l'épistémologie en tant que *discours constitué*; c'est la réflexion épistémologique en tant que réflexion sur la constitution du savoir que je mettrai en avant dans la mesure où cette réflexion participe de la réflexion péda-

gogique, de même que cette dernière s'insère dans une réflexion épistémologique dans la mesure où l'activité d'enseignement, en tant qu'elle est transmission d'un savoir, pose le problème de la relation entre construction du savoir et acquisition du savoir¹⁰. Cela dit, la réflexion épistémologique ne devient consistante que si elle s'appuie sur le discours constitué de l'épistémologie; de même qu'on imagine mal qu'un élève reconstruise de lui-même un savoir déjà constitué (encore que certains courants pédagogistes actuels se complaisent dans une telle conception de l'enseignement), on imagine difficilement une réflexion *spontanée* sur l'activité scientifique; c'est dire que la réflexion épistémologique *personnelle* se construit sur une culture *acquise*, c'est en ce sens que l'on peut demander que la formation des maîtres prenne en charge un enseignement de l'épistémologie et de l'histoire des sciences.

Il nous reste à revenir sur l'épistémologie elle-même; pour cela nous nous plaçons dans une problématique gonséthienne. Prolongeant l'analyse de Gonsseth qui distingue entre une *stratégie de fondement* et une *stratégie d'engagement* dans la construction de la connaissance¹¹, nous distinguerons trois aspects de l'épistémologie, une *épistémologie des fondements*, une *épistémologie du fonctionnement* et une *épistémologie des problématiques*¹².

L'épistémologie des fondements se propose l'étude des conditions de légitimation de l'activité scientifique sous ses deux formes aujourd'hui canoniques, la forme mathématico-logique et la forme expérimentale (encore faut-il préciser ce que chacune de ces deux formes signifie dans le cadre d'un domaine donné de la connaissance). Nous pouvons distinguer deux grandes formes de cette épistémologie des fondements, une forme *métaphysique*, laquelle s'appuie sur une ontologie des objets (que l'on se situe dans une philosophie empiriste où les objets mathématiques sont des *abstractions* issues de la connaissance sensible, ou que l'on adopte un point de vue platonicien), et une forme *analytique*, laquelle s'appuie essentiellement sur une analyse du langage conduisant à expliciter ce que l'on pourrait appeler *la grammaire du raisonnement*, les objets étant définis (ou redéfinis) par un système de relations donné *a priori*. En ce qui concerne les mathématiques, on peut ainsi distinguer entre une *mathématique des objets* fondée sur les vérités premières que sont les axiomes (propositions évidentes par elles-mêmes) et une *mathématique des relations* comme se présente la construction hilbertienne¹³. La diversité des modes de raisonnement qui ont constitué dans l'histoire ce que l'on appelle la démonstration et la diversité des conditions de légitimation de ces raisonnements nous amène à prendre en compte la diversité des approches du problème des fondements et en particulier son historicité. L'étude de l'épistémologie des fondements se pose ainsi doublement; d'une part une étude *synchronique* s'intéressant aux principes qui régissent les règles de raisonnement, d'autre part une étude *diachronique* dont l'objet est l'étude des transformations des conditions de légitimation du raisonnement dans l'histoire, ce qui pose le double problème des raisons de ces transforma-

tions d'une part et d'autre part des *invariants historiques*¹⁴ qui font que l'on reconnaît une unité dans les diverses formes des mathématiques à travers les âges.

L'épistémologie du fonctionnement peut être considérée comme l'analyse des procédures, moins dans leurs fondements que dans leur signification, autant sur le plan proprement technique que sur le plan conceptuel. Il s'agit ici moins de rechercher un discours fondateur que d'explicitier comment des procédures, des modes de raisonnement ou des modes de recherche se sont constitués et comment ils ont été et sont utilisés. Ceci nous renvoie encore une fois aux raisons qui conduisent à fabriquer de tels procédures, c'est-à-dire aux problèmes qui en sont à l'origine.

L'épistémologie des problématiques se propose d'analyser comment les problèmes qui ont conduit l'homme à fabriquer ce mode de connaissance que nous appelons la connaissance scientifique ont modelé les théories inventées pour résoudre ces problèmes. Si, comme le dit Max Weber, "*la construction des concepts dépend de la façon de poser les problèmes, laquelle varie à son tour avec le contenu même de la civilisation*"¹⁵, c'est à travers les problèmes que la méthode scientifique s'est construite et c'est dans le caractère même de ces problèmes et leur formulation que l'on peut essayer de comprendre comment se sont mis en place les notions plus ou moins sophistiquées (artificielles!) qui constituent la science. Cela nous conduit à privilégier la notion de problématique (ou de champs de problèmes¹⁶) dans l'étude des conditions de la construction de la science, problèmes de fondements et règles de fonctionnement s'articulant autour des problématiques dans lesquelles ils se situent.

C'est avec l'épistémologie des problématiques que je reviendrai sur l'histoire des mathématiques, dans la mesure où une analyse historique de l'évolution d'un domaine de la connaissance nous permet de mieux appréhender les diverses significations de ce domaine de la connaissance. Pour préciser ce point, il nous semble nécessaire de mettre l'accent sur l'ambiguïté épistémologique de l'histoire des sciences et par cela même sur l'ambiguïté de l'intervention de l'histoire des sciences dans l'enseignement scientifique.

Dans l'introduction des *Fondements de l'Arithmétique*, Frege écrit, à propos de la méthode historique:

*"La méthode historique, qui veut surprendre la genèse des choses et connaître l'essence par la genèse, a sans doute une vaste juridiction; elle a aussi ses limites."*¹⁷

Nous ne discuterons pas ici le point de vue de Frege qui oppose une recherche strictement logique à la recherche historique; nous voulons seulement, nous appuyant sur la critique de Frege, mettre l'accent sur l'ambiguïté de ce que l'on appelle la méthode historique.

On peut demander à l'histoire de découvrir l'essence des choses en retrouvant leur genèse, ce qui suppose une signification première originelle, la compréhension des choses passant nécessairement par les retrouvailles de cette signification première. L'histoire devient ainsi sa propre négation, son objet est moins de comprendre un processus historique en tant que tel que de s'appuyer sur le développement historique pour redécouvrir un sens originel perdu¹⁸; en ce qui concerne l'enseignement, la méthode historique serait alors le moyen d'atteindre cette signification première. La méthode historique ainsi conçue repose sur une double illusion, d'une part l'existence d'une signification première assimilée à l'essence des choses, d'autre part la nécessité d'atteindre cette signification première pour comprendre les choses que l'on étudie; c'est une telle conception de l'histoire que critique, avec raison, Frege.

On peut aussi chercher dans l'histoire moins une origine illusoire que la compréhension d'un certain type de développement; en ce qui concerne l'histoire des sciences, la question n'est plus celle de la genèse d'une notion, au sens où cette genèse nous donnerait la clé, c'est-à-dire le moyen d'atteindre l'essence de cette notion, elle est celle d'une part des conditions de son émergence lorsque cela est possible¹⁹, d'autre part des modes de développement de cette notion, ce qui nous renvoie à l'épistémologie des problématiques. Dans une telle conception, la mise en place d'une perspective historique dans l'enseignement a pour objet, moins un enseignement en tant que tel de l'histoire que la problématisation des notions enseignées; que les problématiques soient alors les problématiques originelles ou non devient alors de peu d'importance.

C'est, bien évidemment, cette seconde conception de l'histoire qui sous-tend cet exposé, la place de l'histoire des sciences dans l'enseignement des sciences se situant essentiellement dans ses implications pédagogiques, autrement dit, dans ce qu'elle permet de comprendre de la science enseignée; c'est en cela que l'introduction d'une perspective historique dans l'enseignement d'une science diffère d'un enseignement de l'histoire de cette science. Cela nous conduit à distinguer, d'une part le rôle de la connaissance historique dans l'élaboration de l'enseignement, lequel relève du métier d'enseignant (ce qui pose la question de la place de l'histoire des sciences dans la formation des maîtres), d'autre part l'intervention effective de l'histoire des sciences dans l'enseignement. La mise en place d'une perspective historique dans l'enseignement n'implique en rien que l'histoire apparaisse en tant que telle dans l'enseignement lui-même, c'est alors au maître que revient la détermination de la part effective d'histoire (cours d'histoire proprement dit, lecture de textes anciens, reconstitution de problèmes dits historiques²⁰,...) intervenant dans la classe, ce qui suppose que le maître ait, d'une part la connaissance des aspects historiques de ce qu'il enseigne, d'autre part qu'il ait su porter sur ces aspects historiques un regard épistémologique.

C'est par la prise en compte de l'aspect problématique de la constitution du savoir que l'épistémologie peut jouer un rôle dans la pratique

enseignante. L'enseignement scientifique se situe ainsi moins dans l'apprentissage des procédures (même si cet apprentissage constitue une part importante de l'enseignement scientifique, au sens où les gammes constituent une part importante de l'apprentissage d'un instrument de musique) que dans la mise en place des problématiques qui donnent sa signification au savoir enseigné. C'est le sens que l'on peut donner à cette perspective historique dans l'enseignement des mathématiques dont nous avons parlé ci-dessus.

Une telle conception problématique me semble alors contradictoire avec l'analogie développée par Piaget entre le développement historique des sciences et le développement personnel de la connaissance, entre la phylogenèse et l'ontogenèse, pour reprendre une terminologie devenue classique. L'analogie piagétienne repose sur l'hypothèse de l'existence de structures psychologiques profonde qui régissent, *via* les mécanismes de l'accommodation et de l'assimilation, l'acte de connaître, ce que l'on appelle aujourd'hui la *cognition*. On retrouve ici, sous une forme qui se veut scientifique, une conception statique de l'histoire (que ce soit l'histoire collective ou l'histoire individuelle), celle-ci relevant moins de l'invention que d'une téléologie qui la conduit vers ce qu'elle ne peut pas ne pas être²¹; la connaissance se trouve ainsi identifiée à la cognition, ce qui en occulte les enjeux²². En ce qui concerne les mathématiques, cette analogie a conduit Piaget à identifier les structures profondes de la connaissance mathématique avec les structures-mères de Bourbaki (structures d'ordre, structures algébriques, structures topologiques)²³. C'est ainsi que Piaget explique le développement de la géométrie, *via* la découverte successive par l'enfant des structures topologiques, projectives et métriques, conformément à la reconstruction bourbakienne, oubliant les enjeux qui ont conduit à mettre en place au cours de l'histoire, et dans l'ordre inverse de l'ordre génétique piagétien, la géométrie métrique, les notions projectives et les structures topologiques; il est vrai que Piaget explique:

*"Si, historiquement, ces éléments semblent donnés antérieurement à la découverte de la structure, et si cette dernière joue ainsi essentiellement le rôle d'un instrument réflexif destiné à dégager leurs caractères les plus généraux, il ne faut pas oublier que, psychologiquement, l'ordre de la prise de conscience renverse celui de la genèse: ce qui est premier dans l'ordre de la construction apparaît en dernier à l'analyse réflexive, parce que le sujet prend conscience des résultats de la construction mentale avant d'en atteindre les mécanismes intimes."*²⁴

ce qui me semble pour le moins peu convaincant.

Il semble ici que les conceptions de Piaget, enthousiasmé de sa rencontre avec les mathématiciens²⁵, relève d'un malentendu sur la notion de structure, malentendu qu'il faudrait replacer, du point de vue de l'histoire des idées, dans l'histoire des courants structuralistes du milieu de ce siècle. En fait, le point de vue piagétien subordonne les aspects probléma-

tiques de la connaissance (au sens que nous avons dit ci-dessus) à la conception structurale, laquelle se propose, par souci de cohérence et de simplicité, la reconstruction de la connaissance; en ce sens les conceptions piagésiennes nous renvoient à une ontologie (au sens métaphysique du terme) des structures, position paradoxale pour qui se proposait de construire une épistémologie positive²⁶. Comment peut-on comprendre, du point de vue de Piaget, la distinction signalée ci-dessus, entre une mathématique des objets et une mathématique des relations, si ce n'est en recourant à une conception téléologique de l'histoire, banale il est vrai, la rigueur hilbertienne rectifiant les fameuses lacunes d'Euclide et le point de vue structural apparaissant comme un aboutissement de la connaissance mathématique; les enjeux mathématiques qui ont conduit Hilbert à mettre en place le formalisme se réduiraient donc à la seule nécessité d'atteindre enfin la vérité structurale, de réconcilier enfin les mathématiques et la psychologie.

Le problème posé ici n'est autre que celui du lien complexe entre l'épistémologie, considérée comme une chapitre de la philosophie, et la psychologie cognitive; il me semble que l'explicitation d'un tel lien, pour se construire en dehors des confusions (telle celle de Piaget) ou des anathèmes (telle les positions du psychologisme et de l'antipsychologisme), doit commencer par une analyse de la distinction entre cognition et connaissance.

A travers cette critique de Piaget nous voulons revenir sur une conception de l'intervention de l'histoire des mathématiques dans l'enseignement qui risque de conduire à chercher, *via* cette intervention, des solutions aux difficultés propres aux mathématiques, soit en s'appuyant sur des problématiques qui n'ont plus aujourd'hui la signification de l'époque, soit en espérant revenir à des significations originelles considérées comme les *vraies* significations (au sens où nous l'avons dit ci-dessus), quitte à *tordre* ces significations pour mieux *harmoniser* l'ancien et le moderne.

Le rôle d'une intervention de l'histoire dans l'enseignement reste donc essentiellement de mettre en valeur les enjeux de la construction de la connaissance; c'est en ce qu'elle s'appuie sur une réflexion d'ordre épistémologique qu'elle peut permettre de donner à *ceux qui sont enseignés* (pour reprendre l'expression de Sanchez citée en exergue) les moyens de comprendre *la force de ce qui leur est enseigné*.

¹Francisco Sanchez, *Il n'est science de rien* (1581) (traduit du latin par Andrée Camparot), Klincksieck, Paris 1984

²Nous ne poserons pas ici la question des raisons qui conduisent à vouloir rendre accessible au plus grand nombre la connaissance des mathématiques, on peut considérer que ces raisons s'appuient d'une part sur l'idéal de démocratisation issu des *Lumières*, d'autre part sur l'*idéologie des mathématiques partout* défendue par les réformateurs des *mathématiques modernes* (cf. Rudolf Bkouche, "L'enseignement des mathématiques en

France, 1970-1990" in *La Science au Présent* (2 volumes), Encyclopédie Universalis, Paris 1992, volume II, p. 491-493)

³La question reste posée de la part nécessaire de ces mathématiques pour tous, nous ne l'aborderons pas ici. Notons aussi que le développement d'un certain antimathématisme peut remettre en question cette conception d'un enseignement des mathématiques pour tous; ce n'est pas le lieu ici de développer les raisons de cet antimathématisme, renvoyant, en attendant un article à venir (!), à notre point de vue "L'achèvement de l'enseignement des mathématiques" in *Repères-IREM* n°21, octobre 1995.

⁴Pour une présentation de ce courant, nous renvoyons à l'ouvrage édité par la Commission Inter-IREM Epistémologie, *Pour une perspective historique dans l'enseignement des mathématiques*, Bulletin Inter-IREM, Lyon 1988

⁵Ce danger est souligné par Evelyne Barbin qui explique, dans la préface de l'ouvrage cité ci-dessus, qu'il ne faut pas attendre de cette perspective historique la solution à tous les problèmes d'enseignement.

⁶J'insiste sur le fait que je me place ici du point de vue de l'enseignant à l'exclusion de toutes considérations sur les élèves. Celles-ci sont secondes (ce qui ne signifie pas secondaires) dans la mesure où c'est la construction par *celui qui enseigne* de son propre rapport au savoir qu'il enseigne qui conditionne son enseignement et qui peut lui permettre de penser, avec quelque pertinence, le problème de l'apprentissage de sa discipline par les élèves. Il est vrai que l'activité d'enseignement conduit *celui qui enseigne* à transformer son propre rapport au savoir et par cela-même sa façon d'enseigner, mais une telle transformation suppose un socle initial à partir duquel un enseignant peut définir les conditions de son enseignement.

⁷J'insiste sur le fait que je me place ici du point de vue de l'enseignant à l'exclusion de toutes considérations sur les élèves. Celles-ci sont secondes (ce qui ne signifie pas secondaires) dans la mesure où c'est la construction par *celui qui enseigne* de son propre rapport au savoir qu'il enseigne qui conditionne son enseignement et qui peut lui permettre de penser, avec quelque pertinence, le problème de l'apprentissage de sa discipline par les élèves. Il est vrai que l'activité d'enseignement conduit *celui qui enseigne* à transformer son propre rapport au savoir et par cela-même sa façon d'enseigner, mais une telle transformation suppose un socle initial à partir duquel un enseignant peut définir les conditions de son enseignement.

⁸On peut concevoir cependant que l'intérêt propre pour l'épistémologie et l'histoire de la discipline (curiosité intellectuelle pure indépendante de toute considération d'enseignement) influe sur la pratique du métier, on peut concevoir aussi que les intérêts d'ordre épistémologique ou historique liés à la pratique du métier conduisent à découvrir un intérêt propre pour l'épistémologie. Tout cela nous rappelle le caractère intellectuel du métier d'enseignant, caractère qui nous semble quelque peu oublié aujourd'hui.

⁹C'est ainsi que Emile Picard écrit: "On doit d'ailleurs reconnaître qu'il est indispensable, pour le progrès de la science, que les choses paraissent simples" in *La Science Moderne*, Flammarion, Paris 1914, p. 68

¹⁰Le discours pédagogique actuel insiste trop souvent sur la place de la construction du savoir au dépens de l'acquisition du savoir, comme si le rôle de l'enseignement se situait moins dans la transmission d'un savoir déjà constitué que dans la possibilité pour l'élève de construire un savoir qui lui serait propre. On ne construit pas du savoir *ex nihilo*, l'autonomie de l'élève passe par l'appropriation d'un savoir qui *a priori* n'est pas le sien et l'enseignement a justement pour but qu'il devienne sien; c'est bien parce qu'il a acquis du savoir que l'élève peut construire du savoir. Quelle serait l'autonomie d'une personne qui n'aurait pas *acquis* sa langue maternelle, à laquelle on aurait laissé la *liberté* de construire sa propre langue?

¹¹Ferdinand Gonseth, *Le référentiel, univers obligé de médiation*, L'Age d'Homme, Lausanne 1975, préface.

¹²Pour une étude de ces trois aspects de l'épistémologie, nous renvoyons à un article à paraître.

- ¹³Rudolf Bkouche, "Le projectif ou la fin de l'infini" in *Histoires d'infini*, Actes du Colloque Inter-IREM Epistémologie (Brest 1992), IREM de Brest 1994 et "Axiomatique euclidienne et axiomatique hilbertienne" (à paraître in *Mnémosyne*).
- ¹⁴Pour la notion d'invariant historique, nous renvoyons à la leçon inaugurale de Paul Veyne au Collège de France (Paul Veyne, *L'inventaire des différences*, Seuil, Paris 1976)
- ¹⁵Max Weber, *Essai sur la théorie de la science* (traduit par Julien Freund), Plon, Paris 1965, p. 203
- ¹⁶pour reprendre l'heureuse expression du Groupe d'Enseignement Mathématiques de Louvain-la-Neuve (G.E.M.) (cf. Rudolf Bkouche, Bernard Charlot, Nicolas Rouche, *Faire des mathématiques: le plaisir du sens*, Armand Colin, Paris 1991, chapitre XII).
- ¹⁷Gottlob Frege, *Les Fondements de l'Arithmétique* (1884) (traduction et introduction de Claude Imbert), Editions du Seuil, Paris 1969, p. 119
- ¹⁸Nous rapprocherons cette conception de l'histoire des conceptions de Hegel qui, en cherchant une signification globale de l'histoire, se propose moins de l'étudier dans sa réalité que de la redéfinir afin de la mieux placer dans son cadre supposé. Dans ces conditions, *l'essence des choses* représente moins le développement historique que les conceptions de l'historien, autrement dit, ce qui soutient l'histoire ne relève plus de l'histoire.
- ¹⁹Rappelons que Frege, dans l'ouvrage cité ci-dessus, se propose d'explicitier la notion de nombre entier. On sait que cette notion remonte aux débuts de l'histoire de l'humanité et qu'il ne peut être question de connaître sa genèse autrement que par une reconstruction hypothétique, cette reconstruction s'appuyant sur les conceptions propres de son auteur (cf. note ?). Si une telle méthode de reconstruction peut avoir son utilité dans le travail de l'historien des sciences, elle est essentiellement d'ordre heuristique.
- ²⁰moins pour dire que tel problème a été étudié par untel à telle époque, ce qui présente peu d'intérêt, que pour mettre en place, sous une formulation moderne, une problématique significative.
- ²¹C'est ce caractère téléologique qui transparait dans l'ouvrage de Jean Piaget et Roland Garcia, *Psychogenèse et Histoire des Sciences*, Flammarion, Paris 1983
- ²²On retrouve cette identification dans certaines théories cognitivistes d'aujourd'hui.
- ²³Jean Piaget et al., *L'Enseignement des mathématiques*, publié par la CIEAEM (Commission Inter-national pour l'étude et l'Amélioration de l'Enseignement des Mathématiques), Delachaux & Niestlé, Neuchâtel Paris 1955, chapitre premier, "Les structures mathématiques et les structures opératoires de l'intelligence" par Jean Piaget, chapitre III, "L'abstraction en mathématiques et l'évolution de l'algèbre" par Jean Dieudonné.
- ²⁴Jean Piaget et al., *L'Enseignement des mathématiques*, op. cit. p. 14
- ²⁵Jean Piaget et al., *L'Enseignement des mathématiques*, op. cit.
- ²⁶Jean Piaget, *Introduction à l'épistémologie génétique* (2 tomes), PUF, Paris 1950; réédition 1973, et du même auteur, *Sagesse et illusions de la philosophie*, PUF, Paris 1965, réédité en 1992.

PERILS AND PLEASURES OF THE INTERNET

Panel presentation

Jan van Maanen, University of Groningen, The Netherlands

Communication between scientists and storage of scientific information has been changing rapidly in the last two decades, as have the mechanisms for popularising knowledge and making it widely available. The introduction of new media for data transmission, data processing and data storage, especially the various facilities of Internet, strongly influence scientific and educational life. These changes form, in the judgement of many, a revolution comparable in its social effects to the invention of writing or of printing. Appreciating the pleasures and understanding the perils of this revolution are essential, especially for those involved with the history of mathematics and its use in education.

At first sight it seems mainly to be a question of scale and speed. Just as the invention of bookprinting enlarged the scale on which information could be stored and transmitted, the World Wide Web introduces yet another such magnification. And just as telegraph and telephone speeded up the communication between scientists, Electronic Mail brings yet another such acceleration. Increase of the information available, better access to it, and decrease of waiting times, what other wishes could a scientist have? So it seems, in the first euphoria about what is new. Without doubt more PLEASURES of the Internet can be added.

The historical parallel may be extended further. Bookprinting not only formed progress but also created problems. The infrastructure of knowledge changed; several monasteries lost their major task (after praying, of course); commerce determined the market; the maintenance of quality and morality had to be organised along new paths (leading, for example, to the Index); and problems of intellectual ownership started to arise (eventually leading to the introduction of the copyright principle).

Many such things seem to happen again nowadays. Perhaps our knowledge of history will help us to be more informed participants in the process?

- Maintenance of quality is a major issue. Who governs the standards of large collections of data (such as WWW-pages)? What further training is needed for users to help them judge false or misleading information? Is this possible?
- Maintenance of data is another point. There is often no permanent record of discussion lists. If an archive is kept, on the Web, for instance, how does one select, manage and index the material in it?
- Authorship becomes vaguer, and with it an author's pride in ensuring the accuracy of information and judgement. Are we to consider a learned, referenced and not disputed statement in a discussion list as an accepted piece of information? Is such a statement a publication? And isn't it easy to make and use such a statement in a list in too early a state?
- And what about "overstated points" in discussions: is anyone free to shout (electronically, that is) anything he or she (but maybe more often he) wants? Journals

sometimes also publish unbalanced points, but then at least the editor or a board can take a stand. Should the owner of a list intervene? And on what intellectual grounds? Not to speak about abusive off-list mail. Or is this the responsibility of the receiver, who can give up posting messages or even unsubscribe?

- Again with respect to discussion lists: there is a limit to the number of messages one can handle. So, what are the 'level' and the 'boundaries' of any list, and how does one maintain them? is anybody free to ask any question? and expect an answer? do posers of questions have a responsibility for checking in a book first? But what of those with little access to books of the right sort?
- Both pleasures and perils are well exemplified in some well-known recent examples: Fred Rickey's math-history-list, under the auspices of the Mathematical Association of America; the St Andrews archive of biographies of mathematicians; the www home pages of organisations and conferences. All these can bring great pleasures, provided the perils are understood and guarded against, and where possible resolved.

These questions, and related questions put by the audience, will be addressed by the panel.

MATHEMATICAL PROOF IN HISTORY

Panel presentation

Jesus Hernandez, Universidade Autonoma de Madrid, Espanha
Victor Katz, University of the District of Columbia, USA

The aims of this series of short lectures is to provide some elements of discussion and concrete instances of proofs in mathematical activity and its incidence on teaching and pedagogy. Some of these problems were considered in the general lecture given by one of the organisers (J.H.), which can be considered as an introduction to this panel as well.

The lectures cover very different aspects and do that in different ways. However, all of them have some features in common as, for example, a considerable historical weight and a more or less thorough examination of its incidence on the teaching of mathematics.

Some of the lectures are devoted to (in some sense) rather restricted topics, as is the case of Cartesian geometry (E. Barbin) or proof in Chinese mathematics (Man-Keung Siu), but they concern very general questions concerning proofs and its use in mathematics. Others cover much more general areas (Calculus or Mathematical Logic) in some of the corresponding developments. The emphasis on the historical evolution of theories and problems and the consequences implied on the effective work of professional mathematicians and on presentation of mathematical contents in teaching is very important. The talk by V. Katz combines different steps of the development of a very precise topic (mathematical induction) with its role in the proofs usually presented for a some well known elementary results. Finally, the talk by I. Kleiner presents many different versions of a “general form” in mathematics, as the “Principle of continuity” could be considered. This is a very interesting example of how analogy can be used in several ways in current work on teaching.

We have tried to emphasize on the cultural side of mathematics and its relationship with other aspects of the evolution of some ideas along history. From this point of view the technical mastering of the contents is not very important.

workshops
ateliers
sessões práticas

The organization of workshops were proposed by participants. There is two durations for workshops, 1h.30 and 3h.00. Writing texts for inclusion in the proceedings was optional. Titles of workshops without texts in these proceedings are listed at the end of this volume..

L'organisation d'ateliers résultent des offres des participants. Il y a deux durées pour les ateliers: 1h.30 et 3h.00. L'inclusion de textes dans les actes était une option des organisateurs. Vous trouverez dans les dernières pages de ce volume les titres des ateliers qui n'ont pas de textes inclus dans ces actes.

As sessões práticas resultaram da oferta dos participantes. Existem sessões práticas de 1h.30 e de 3h.00. A inclusão de textos nas actas era opcional no caso das sessões práticas. Nas últimas páginas deste livro encontrará os títulos das sessões práticas que não têm textos incluídos nestas actas.



COMMENT FONCTIONNE LA GEOMETRIE ALGEBRIQUE.

Alain BERNARD, IREM de Montpellier.

L'algèbre n'est qu'une géométrie écrite,
la géométrie n'est qu'une algèbre figurée.

Sophie Germain.

« Contrairement à une croyance très répandue, l'idée d'une géométrie « pure », séparée de l'algèbre, est tout à fait récente (début du XIX^e siècle); elle était complètement étrangère aux Grecs, qui ne connaissaient pas l'algèbre au sens moderne. En revanche, leur géométrie était vraiment une « algèbre-géométrie », un mélange complexe de raisonnements purement géométriques, et de calculs sur des rapports de segments. » (Dieudonné, 1982).

Fondée sur le système de mesure chaldéo-sumérien vieux d'environ 2000 ans, la géométrie grecque fut le fondement des méthodes des mathématiciens jusqu'au XVII^e siècle.

En 1637, Descartes publie sa « Géométrie » créant la méthode des coordonnées et par là même, la géométrie algébrique. Son ami Fermat complète son travail en reliant les droites et les coniques aux équations du premier et du deuxième degré. Mais presque simultanément, Fermat énonce une conjecture d'essence purement arithmétique. Bien dans la lignée des problèmes numériques « plaisants et délectables » du Moyen-âge. Pour Fermat la démonstration ne fait pas de doute: la marge est trop petite pour la rédiger, c'est tout ! La conjecture va résister jusqu'en 1993 (ou 1994) et sera résolue dans un tout autre domaine que l'arithmétique.

S'il est évidemment impensable d'évoquer cette démonstration, il est facile de voir comment on transforme un énoncé d'arithmétique en un énoncé de géométrie algébrique.

$$x^n + y^n = z^n \text{ devient } \left(\frac{x}{z}\right)^n + \left(\frac{y}{z}\right)^n = 1 \text{ puis on étudie } P(a,b) = a^n + b^n - 1$$

Le problème est alors de savoir si la courbe d'équation $a^n + b^n = 1$ a des points $M(a,b)$ à coordonnées rationnelles ou pas. Fini l'arithmétique! (à première vue)

Le problème a été transféré en géométrie algébrique.

De plus ce n'est pas la première fois que ce transfert survient. Le théorème fondamental de l'algèbre fut démontré par Gauss en 1799. Son idée fut de représenter les nombres complexes $z = a + bi$ par les points $M(a,b)$ du plan complexe ainsi créé. Au lieu d'étudier une équation, Gauss étudie l'intersection de 2 courbes du plan. Là était la solution d'un problème vieux de 170 ans (Girard, 1629).

Mieux ! La démonstration de Gauss passe par l'intuition suivante: Deux courbes algébriques (C) et (D) dont les asymptotes « se succèdent » en polaires, se coupent en au moins un point. L'existence de ce point prouve l'existence d'une solution pour l'équation. Gauss n'a aucun doute concernant l'existence du point d'intersection. Pourtant, il note: « autant que je sache, personne n'a élevé le moindre doute là-dessus.

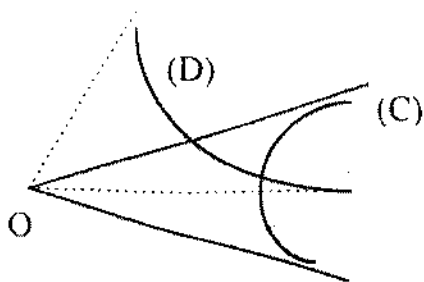

Cependant si quelqu'un le demande, j'entreprendrai à une autre occasion de fournir une démonstration qui ne puisse être soumise à aucun doute. » (Histoire de problèmes page 346)

A ce jour, aucune démonstration du théorème fondamental de l'algèbre ne peut se faire uniquement en algèbre, sans apport de l'espace.

« Etymologiquement, la géométrie est la science des mesures terrestres; issue des réflexions des arpenteurs, elle est inséparable de la notion de nombre » Jacqueline Lelong. Impossible de faire de la géométrie sans nombre (même si Euclide repousse l'introduction des nombres au livre VII).

L'apport de l'algèbre au 17^è siècle est un « premier pas vers une alliance plus intime entre l'algèbre et la géométrie clef universelle des mathématiques » (Chasles, Aperçu historique). Nous voyons cette indispensable « alliance universelle » dans les grands théorèmes CREATEURS des mathématiques : Thalès, Pythagore, notion de dérivée, notion d'intégrale, espace vectoriel, fonctions, espaces métriques, etc....

Hilbert dans l'introduction de ses « 23 problèmes » en 1900 écrit: « Les signes et les symboles de l'Arithmétique sont des figures écrites, et les figures géométriques sont des formules dessinées; aucun mathématicien ne pourrait se passer de ces formules dessinées, pas plus qu'il ne pourrait, dans les calculs, se passer de parenthèses ou crochets ou autres signes analytiques. »

En 1982, Dieudonné, autre chantre de l'axiomatique, évoquait « la domination universelle de la géométrie » et écrivait: « Au contraire, je pense qu'en éclatant au-delà de ses étroites frontières traditionnelles elle a révélé ses pouvoirs cachés, sa souplesse et sa faculté d'adaptation extraordinaire, devenant ainsi un des outils les plus universels et les plus utiles dans tous les secteurs des mathématiques. Et si quelqu'un parle de la « mort de la géométrie », il prouve simplement qu'il est complètement ignorant de 90% de ce que font les mathématiciens aujourd'hui. »

Alors d'où vient cette domination ?

Du créateur des mathématiques : le cerveau.

Nous connaissons aujourd'hui (un peu) l'organisation du cerveau.

L'hémisphère droit est celui de l'intuition et de l'espace. (Points, courbes ...)

L'hémisphère gauche est celui de l'écriture numérique, algébrique et de la logique. (Equations..) Le corps calleux est chargé de gérer l'alliance intime entre les 2 hémisphères, entre les points et leurs coordonnées.

Voilà une raison pour laquelle la géométrie « pure » du 19^è siècle dut très vite redevenir une géométrie algébrique ou une algèbre-géométrie, recréant cette alliance intime entre les figures de l'espace et l'écriture algébrique.

Alliance intime liée au fonctionnement du cerveau, du cerveau de Gauss, du cerveau d'Abel, du cerveau de Wiles, de tous les cerveaux.

UNE APPROCHE PEDAGOGIQUE DEDUITE DE L'HISTOIRE.

Alain BERNARD, IREM de Montpellier.

En 1964 déjà, Jean Dieudonné pestait contre: « les constructions par la règle et le compas, les propriétés des figures traditionnelles ... les raffinements accumulés par des générations de « géomètres » spécialisés et de professeurs en quête de problèmes d'examen,.... la kyrielle de formules trigonométriques ... ». (Algèbre linéaire et géométrie élémentaire)

Il continuait en remarquant : « que l'on ouvre un livre de l'Université et on constatera aussitôt qu'il n'y est jamais même fait allusion à toutes ces belles choses. » Dieudonné pestait encore contre « toute une impressionnante liste de « sciences » : la géométrie pure, la géométrie analytique, la trigonométrie, etc ... présentées isolément et se targuant chacune de son indépendance. »

L'atelier propose à partir de grands textes historiques classiques de dégager une approche simple, générale et unitaire des mathématiques.

Einstein, dans « le problème de l'espace, de l'éther et du champ physique » montre comment la méthode logico-déductive permet de trouver la sécurité au prix « d'un contenant sans contenu. »

Piaget et Garcia ont dégagé 3 stades de la construction du savoir chez l'enfant qui correspondent à 3 stades historiques: la géométrie d'Euclide, les repères de Descartes et la géométrie des transformations.

Chasles dans son « Aperçu » propose « la clef universelle des mathématiques, alliance intime entre la géométrie et l'algèbre. »

De ces grands textes, nous chercherons à dégager quelques caractéristiques historiques des mathématiques:

I) LA SIMPLICITE.

Dans la classification générale des sciences proposée par Auguste Comte au 19^e siècle, les mathématiques sont « la plus simple et la plus générale des sciences. »

Einstein disait: « Si la nature ne suivait pas des lois simples, alors je cesserais de m'y intéresser. »

II) LE SYSTEME DE MESURE CHALDEO-SUMERIEN.

Environ 2000 ans avant les Grecs, fut créé un système de mesure reliant les segments, surfaces et solides avec leurs longueurs, aires et volumes. Inventé une seule fois par l'être humain (contrairement aux nombreux systèmes de numération) ce système de mesure servit de fondement à la géométrie d'Euclide. Le « miracle » chaldéo-sumérien précéda le « miracle » grec.

III) LA SEULE MATHÉMATIQUE QUE PEUT CREER NOTRE CERVEAU EST DE LA GEOMETRIE ALGEBRIQUE.

Citons Sophie Germain: « L'algèbre est une géométrie écrite, la géométrie est une algèbre figurée. » ou David Hilbert: « Les signes et les symboles de l'Arithmétique sont des figures écrites et les figures géométriques sont des formules dessinées; aucun mathématicien ne pourrait se passer de ces formules dessinées. »

Nous connaissons aujourd'hui un peu le fonctionnement du créateur des mathématiques: le cerveau.

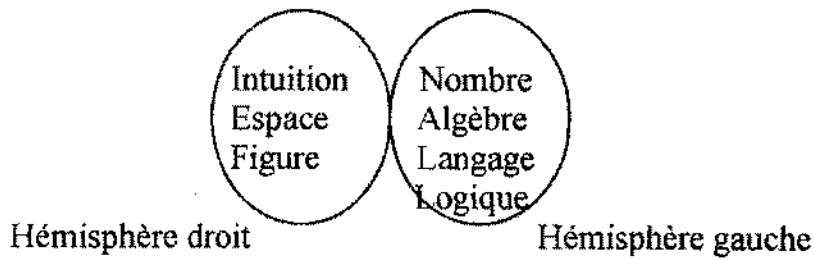

L'histoire des mathématiques est aujourd'hui connue dans ses grandes lignes. Les premières grandes étapes furent: 1) Compter: les nombres entiers
2) Construire des figures simples
3) Mesurer ces figures avec des nombres
4) Dédire des propriétés avec la logique

Les mathématiques sont bien depuis Euclide la science déductive basée sur l'axiomatique. Mais « la sécurité trouvée dans la méthode logico-déductive s'obtient au prix d'un contenant sans contenu. » (Einstein) On ne saurait construire un savoir - une science - par ce qui fut un de ses aboutissements !

IV) LES TROIS LANGAGES

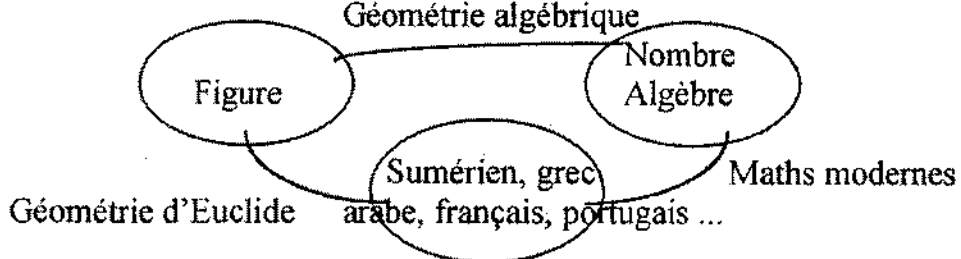

Euclide ne disposait pas de l'écriture algébrique. Son travail était basé sur les figures de l'espace (du plan) et sa langue, le grec.

Les maths modernes se fondaient sur l'axiomatique, l'écriture algébrique et la langue du pays, évitant les figures (mais pas l'espace).

La géométrie algébrique construit les mathématiques à partir de l'intuition spatiale et du langage algébrique.

V) REDONNER DU SENS AUX MATHÉMATIQUES.

En conclusion, la géométrie algébrique réalise un équilibre - toujours précaire - entre l'intuition et le raisonnement, entre l'espace et le langage qui décrit cet espace. La géométrie algébrique en réalisant une « alliance intime » entre l'algèbre et la géométrie doit permettre une construction des maths plus conforme à son développement historique. Les mathématiques sont avant tout un système de mesure puis ensuite une science déductive: compter, construire, mesurer puis déduire. Peut-être notre enseignement scientifique pourrait-il se rapprocher de l'alliance intime laquelle a au moins le mérite de faire fonctionner de façon équilibrée les 2 hémisphères cérébraux. A discuter

UMA ABORDAGEM HISTÓRICO-MATEMÁTICA DOS FUNDAMENTOS DO CÁLCULO DIFERENCIAL: REFLEXÕES METODOLÓGICAS

Arlete de Jesus Brito, UNICAMP (Doutoranda)
Virginia Cardia Cardoso, UNESP RC (Mestranda)

Esta sessão prática tem objetivos em dois níveis distintos. Um deles é levar os professores a uma reflexão sobre os fundamentos do cálculo diferencial, buscando um metaconhecimento desse tema. Para isso utilizaremos a História da Matemática como fonte de problematização.

Serão propostos aos participantes problemas que surgiram na História, tais como os paradoxos de Zenão, o dilema do cone de Demócrito, o traçado da tangente à espiral de Arquimedes, a Teoria das Fluxões de Newton, a Teoria dos Infinitesimais de Leibniz, as tentativas de fundamentação do Cálculo encontradas em Marx e na Análise Não-Standart.

Com tais problemas, pretendemos questionar as concepções que os professores têm de infinitésimos, conjunto contínuo, conjunto denso, tangente a uma curva, levantando, assim, uma discussão sobre conhecimento local e conhecimento generalizado.

O outro objetivo, é examinar os princípios metodológicos que norteiam esta utilização da História da Matemática. Nessa parte do trabalho serão debatidas as diferenças entre as abordagens lógica-matemática, histórico-filosófica e a lógico-matemático-histórico-filosófica. Além disso, tentaremos sistematizar com o grupo de participantes qual o significado de "problematização" nessa última abordagem.

Como procedimentos utilizaremos a leitura de textos e a apresentação dos problemas acima mencionados para discussão, primeiramente em pequenos grupos e a seguir no grande grupo, buscando a sistematização das idéias envolvidas.

Bibliografia

- ARTIGUE, M. - "Épistemologie e didactique" - RDM - Vol 10, nº 23, 1990.
- BARON, M. - *Curso de História da Matemática: as origens e desenvolvimento do Cálculo* - Unidades 1, 2 e 3 - Brasília - Ed. UnB- 1985.
- BLAY, M. - "Deux moments de la critique du calcul infinitésimal: Michel Rolle et George Berkeley" in *Revue d'histoire des sciences* - Tome XXXIX - Juillet-septembre - p: 223-253 - 1986.
- BOYER, C. B. e MERZBACH, U. - *A history of mathematics* - Singapore - John Wiley & Sons - 1989.
- BRITO, A. J. - *Geometrias não-euclidianas: um estudo histórico-pedagógico* - Dissertação de mestrado - FE -UNICAMP - 1995

- CARAÇA, B. J., *Conceitos fundamentais da matemática* - 7ª ed. - Lisboa - 1978.
- CARVALHO, D. L. - *Metodologia do ensino da matemática* - S. Paulo - Cortez Ed. - 1990.
- EDWARDS JR, C. H. - *The historical development of the calculus* - NY - Springer-Verlag - 1979.
- ESTRADA, M. F. - "A história da Matemática no ensino da Matemática" in *Educação Matemática* - nº 27 - p: 17-20 - Revista da Associação dos Professores de Matemática - Portugal - 1993.
- GERDES, P. - "Karl Marx - Arrancar o véu misterioso à matemática" in *Tlanu Revista de Educação Matemática*, nº 5 - Maputo - s/d.
- GRABNER, J. V. - "Is mathematics truth time-dependent?" - *The american mathematical monthly*, abril 1974
- _____, "The mathematicians, the historian, and the history of mathematics" - *Historia Mathematica* - 2:439-447, 1975
- GRATTAN-GUINNESS, I. - *Del Cálculo a la teoria de Conjuntos* - Madrid - Ed. Alianza Universidad - 1984.
- JONES, P. - "The history of mathematics as a teaching tool" - *Historical topics for the mathematics classroom* - Washington, D.C.: NCTM, 1969
- MIGUEL, A. - *Três estudos sobre História e Educação Matemática* - Tese de doutorado - FE - UNICAMP - 1993.
- NEWTON, I. - *Principia - principios matemáticos de filosofia natural* - Vol. 1 - S. Paulo - Nova Stella Editorial - 1990.
- STRUİK, D. J. - *História Concisa das Matemáticas* - Lisboa - Gradiva - 1989.

PASCAL ET LE CALCUL INTEGRAL

Claude MERKER. IREM de Franche-Comté, Besançon, France.

Le *Traité de la roulette* est né d'un défi que Pascal a lancé aux géomètres de son temps. C'est en réalité un ensemble de sept Traités - dont le plu connu est sans doute le *Traité des sinus du quart de cercle*. Il s'agit de résoudre dix-huit problèmes ayant trait à la roulette (la cycloïde), par exemple, trouver le centre de gravité du solide obtenu par révolution autour de la base, ou son centre de gravité, ou... En 1658, Pascal ne disposait pas du calcul par primitive. Bien qu'il soit destiné à résoudre des problèmes liés à la cycloïde, ce Traité est un traité théorique, qui met en place des outils et démontre des théorèmes généraux. Comme le dit Emile Picard « On trouve dans l'ouvrage de Pascal sur la roulette, sous des formes mathématiques extrêmement ingénieuses, les résultats fondamentaux se rapportant à ce que les géomètres appellent aujourd'hui les intégrales curvilignes et les intégrales doubles (...) c'est le premier traité de calcul intégral ». Pascal ne s'intéresse pas aux calculs, ne les effectue jamais, se contente de donner les moyens de les faire.

Une méthode des indivisibles, très pascalienne, sans indivisibles, est un des fils conducteurs du Traité. Des lignes droites ou courbes sont subdivisées à l'infini en « petites portions », sortes de différentielles géométriques rentrant dans la construction de « sommes » variées, intégrales simples, doubles ou triples, pour le dire comme aujourd'hui. Si l'on effectue les calculs omis, il apparaît que ces différentielles sont constamment transformées en d'autres. Trois ingénieuses figures géométriques se chargent de cela, deux d'entre elles échangent différentielles droites et différentielles courbes. Les innombrables échanges se terminent généralement, pour un problème donné, en une somme où les différentielles naissent de l'arc de cercle. Car, pour Pascal, la roulette est un cercle (en un sens à préciser !), et l'intégrale curviligne dans le cercle est la plus naturelle - c'est la seule qu'il effectue ; toutes les autres se déduisent de celle-là par des chaînes de transformations. Le calcul de ces intégrales curvilignes dans le quart de cercle est l'objet du *Traité des sinus du quart de cercle*. Un autre traité, dit *Traité des trilignes* se charge de métamorphoser les intégrales en début de calcul. Quinze propositions générales, lisibles aujourd'hui comme des intégrations par parties y sont démontrées. Elles expriment toutes la permanence d'un attribut géométrique - aire, volume, centre de gravité - relativement à deux modes de calcul.

Le *Traité de la roulette* ignore le calcul par primitive (à une exception près, non repérée comme telle). Mais il met des différentielles sur le devant de la scène. Les différentielles ont une forme géométrique, elles ne s'appellent pas dx, dy, ni ds, mais MM, II ou DD (...) du nom de la subdivision « indéfinie » qui leur a donné naissance. Ces infiniment petits sont élevés à l'ordre un deux ou trois, selon les sommes que considère Pascal. Tout un système d'abréviations, complètement littéraire, est inventé par l'auteur pour parler des différentielles sans les nommer, à tel point qu'elles semblent souvent aussi absentes que dans la méthode des indivisibles de Cavalieri.

Mais il n'en est rien, car l'expression «somme des sinus» cache des différentielles courbes, «somme des ordonnées» cache des différentielles droites, «somme triangulaire des sinus» cache des différentielles courbes d'ordre 2... Pascal met en pratique ses idées sur la liberté des définitions, et fabrique un code précis d'abréviation du discours. Le *Traité de la roulette* est une œuvre mathématique – par son contenu –, littéraire – par le soin apporté à l'écriture et à l'expression –, logique – par la réflexion sur la définition... Sous-entendues pour ne pas surcharger, les différentielles sont présentes dans la dynamique des calcul qui est un système de leur échange. Pascal a créé, grâce à elles un calcul très articulé sur les objets «sommes», calcul assez riche pour venir à bout de

$$\int \alpha \sin \alpha \cos^2 \alpha \, d\alpha \quad \text{ou} \quad \int \alpha^2 \cos^2 \alpha \, d\alpha$$

avec pour tout symbolisme mathématique des lettres majuscules pour désigner les points, comme Archimède !

Comme la roulette est analysée en une multiplicité de cercles, le *Traité de la roulette* est en réalité un profond *Traité du cercle* qui marque l'entrée des lignes trigonométriques dans le champ du calcul intégral. Le cercle est clos par rapport aux sommations répétées, c'est là la chance qu'a eue Pascal dans son projet.

Une intuition sûre de l'infini guide Pascal tout au long de ces pages, à une époque où l'on ne peut pas faire de calcul infinitésimal sans prendre certaines distances avec le rationalisme. Qui peut être mieux placé que celui qui a si bien analysé l'esprit de géométrie et l'esprit de finesse, pour justifier ce qui se passe au moment où les «petites portions» s'évanouissent ? Les mathématiques, ni les sciences n'étaient depuis longtemps le souci principal de Pascal. Nous espérons dans cet atelier montrer comment Pascal a mené un calcul de l'infini de manière confiante, habitué qu'il était à penser les relations entre Dieu et le Monde en termes d'ordres d'infinis.

Le *Traité de la roulette* figure dans les deux éditions :

PASCAL *Œuvres complètes*, Jacques Chevalier, Bibliothèque de la Pléiade, 1954.

PASCAL *Œuvres complètes*, Jean Mesnard, Desclée de Brouwer, Tome IV.

Pour comprendre mieux l'homme, le croyant, l'écrivain qu'était Pascal, on pourra consulter ces ouvrages :

H. GOUHIER *Blaise Pascal, commentaires*, Bibl. d'histoire de la philosophie, Vrin.

L. GOLDMAN *Le Dieu caché. Etude sur la vision tragique dans les Pensées de Pascal et le théâtre de Racine*, nrf, Gallimard, 1975

PH. SELLIER *Pascal et Saint Augustin*, Armand Colin, 1970.

THE HISTORY OF THE RELATION BETWEEN MATHEMATICS AND PHYSICS AS AN ESSENTIAL INGREDIENT OF THEIR PRESENTATION¹

Constantinos Tzanakis,

Department of Education , University of Crete, 74100 Rethymnon, Greece

In this workshop we consider in detail specific examples from the relation of mathematics and physics, thus illustrating a method of presentation in which the historical evolution of the subject presented, plays a crucial role. We call this a genetic method, in the sense that a subject is studied only after sufficient motivation for such an enterprise has been given, based at least in part on the consideration of questions and problems that served as prototypes in the historical development of the subject. In this way it is possible:

(a) to realize fundamental difficulties present in the historical process and use them as a guideline in a classroom presentation or writing of a textbook (examples 1 and 2 below)

(b) to motivate the introduction of new concepts, methods or theories via historically relevant examples of questions and problems that are answered in this way for the first time or are seen in a new, more fruitful perspective (examples 3, 4, 7, 8, 9)

(c) to interrelate a priori different domains (examples 5, 6, 7)

(d) to incorporate many details in sequences of exercises, which starting from simple considerations, may lead to deeper, nontrivial results, thus making problem solving an essential ingredient of the presentation (examples 3, 5, 9).

As already mentioned, this genetic method is illustrated via examples based on the relation of mathematics and physics, as this may appear either at a high school or university curriculum. Specifically, we consider the following examples:

1) The concepts of velocity and its relation to the concept of the derivative of a function

2) The introduction of abstract algebraic concepts, like group structures, vector spaces etc.

¹ This is an abstract of a 3 - hour workshop.

3) Kepler's planetary laws and the formulation of Newton's universal gravitation as an application of differential calculus and analytic geometry

4) An elementary formulation of Fermat's Principle of Least Time and its application to the derivation of the laws of Geometrical Optics (laws of reflection and refraction)

5) Simple matrix algebra and an elementary exposition of the foundations of the Special Theory of Relativity (an elementary derivation of the Lorentz transformation and the relativistic law of velocity addition)

6) Introduction of noneuclidean geometric concepts, based on physical arguments (elementary reference to the foundations of the General Theory of Relativity)

7) Hamilton's unified approach to Classical Mechanics and geometrical optics, and the formulation of Wave Mechanics

8) Introduction of basic concepts of vector analysis, in connection with classical electromagnetic theory

9) Introduction of basic concepts of linear functional analysis, motivated by the needs of Quantum Mechanics.

Examples 1 - 5 and partly example 6 can be incorporated in a high school mathematics and/or physics course, whereas the remaining examples may constitute part of a corresponding undergraduate university curriculum.²

² For further details on the genetic method, see the paper with the same title in these proceedings.

Teaching Mathematics in Somalia

Franco Favilli, Jama Musse Jama, Dipartimento di Matematica, Università di Pisa.

The social context and the culture of a territory play an important role in the teaching of any discipline in that area. In this workshop we want to make some observations on the teaching of mathematics in Somalia. However the current situation of the country obliges us to look into how it was in 1990 and subsequently to prepare a focus issue on developing an appropriate mathematics curriculum, based on the socio-cultural context, which will enable the students to understand the concepts of mathematics.

The Somali mathematics syllabus was influenced by the western countries syllabi. The textbooks were dealing with a number of arguments, provided for by that syllabus, occasionally with extreme superficiality: in their drafting it was dealt with the correspondence to the arguments in the syllabus instead of dealing with their usability and student's capacity of understanding. Furthermore, particularly in the last years, a few among the teachers were able to handle these textbooks, because of their limited qualification as teachers and as mathematicians.

In this workshop we provide a proposal of revision of the syllabus and textbooks allowing for today's real situation of the country. The emphasis is on reviewing the existing materials, making a conceptual analysis as well as indicating orientations for fruitful study of mathematics.

Any such revision must consider some fundamental elements connected to the Somali history, culture and tradition. The script of the Somali language was written only about 25 years ago, therefore the feature of the local culture is the orality.

As a natural consequence, the way of thinking and the expression are, essentially, addressed to the practical experience. Two characters of the common population are particularly apprent:

I. a great mnemonic ability;

II. the lack of exercise in reading and interpretating graphical representations.

As to the mathematics these characters imply that the Somali students have

I. easy approaches to problems which require a calculation technique, involving symbolic manipulations, and the ability to remember acquired techniques over a longer period;

II. deep difficulties to face problems of orientation in the space and of plane geometry, as well as to handle abstracting processes.

This happens because students place their full reliance on natural language statements. They would try to memorize these statements without exception, experiencing a great difficulty in learning mathematics. This has a negative effect on students capacity of interpreting and solving a problem.

Re-elaborating programs and school text-books, hence, we must pay a particular attention to the graphic and geometric aspects, as well as to logical arguments which enable students to discover and acquire abstract concepts and techniques.

Probably, it is not necessary, nor opportune, to give the students the same amount of mathematical notions as it is required in the actual syllabi. Surely it could be very useful to bring out, updating those syllabi, the mathematical activities which, belonging to the tradition, are used by the people.

References:

- [1] AA. VV. - *Lingua, pensiero scientifico e interculturalità: l'esperienza dell'interazione universitaria in Somalia*, Atti dei convegni lincei 107, Acc. Naz.le dei Lincei, 1994.
- [2] BISHOP, A. - *Mathematical Education in its Cultural Context*, *Educ. Studies in Math.* 19 (1988), 179-191.
- [3] D'AMBROSIO, V. - *Ethnomathematics: Theory and Pedagogical Practice* I part, *L'educazione matematica*, vol. 2 n. 3 (1995) and II part (to appear in *L'educazione matematica*).
- [4] FAVILLI, F. and VILLANI, V. - *An Ethnomathematical Research: Description and Drawing of a Cube in Somalia*, *Book of abstracts of short presentations*, p-263, ICME 7, 1992.
- [5] FAVILLI, F. and VILLANI, V. - *Disegno e definizione del cubo: un'esperienza didattica in Somalia*, *L'insegnamento della mat. e delle scienze integrate*, vol. 16 n. 10 (1993), 907-925.
- [6] GERDES, P. - *On Culture, Geometrical Thinking and Mathematics Education*, *Educ. Studies in Math.* 19 (1988), 137-162.
- [7] GRIFFITHS, H. B. and HOWSON, A. G. - *Mathematics: Society and Curricula*, Cambridge University Press, 1974.
- [8] NELSON, D. and JOSEPH, G. G. and WILLIAMS, J. - *Multicultural Mathematics: Teaching Mathematics from a Global Perspective*, Oxford University Press, 1993.
- [9] *General Secondary Schools: Syllabi*, Curriculum Development Center, Mogadishu (Somalia), 1985.
- [10] *Somali Text-books of Mathematics*, Curriculum Development Center, Mogadishu (Somalia), 1980-1985.

HOW TO TREAT STUDENTS TO ... CONICS and how to read an ancient French text at school without knowing ... French!

Giuliano Testa, Liceo Scientifico 'P. Liroy', Vicenza, Italy

It is often a rewarding and enriching experience to investigate into the meaning of words and their changes in time when in relation to specific needs they took on new connotations which can only be understood and clarified by tracing their origins.

It is well-known that the names usually applied to conics, which in archaic times were associated to the problem of the application of areas, and therefore with no relation to the plane sections of the cone, were used by Apollonius to denote what we may call a "symptoma" of each conic section.

Therefore the old significance of such names underwent a deep change owing to Apollonius' transference, as reported by Pappus in his VII book of the Collection.

The teaching experience described hereafter had precisely this purpose: to trace the change in meaning of the conic names starting from the Delian problem and its numerous solutions (collected by Eutocius), proceeding to the analysis of the application of areas according to Euclid, to finally outline Apollonius' definitive reshaping.

Such complex and extensive research into the historical, philosophical and cultural background as the ideal setting of the problem took up 50% of the time of the course (8 lessons in November and December 1995); the remaining 50% of the research (8 lessons in February and March 1996) was devoted to the study of the French text of M. de la Chapelle (Debure, Paris, 1765) in the original.

The activity was proposed to a group of 16/17-year-old voluntary students (16 altogether) who, despite the numerous conceptual and linguistic difficulties, followed the course with interest and keen participation. Moreover, the course being scheduled as extra-school curriculum also meant extra work for the students.

The first eight lessons were centred on the teacher's exposition, while in the remaining eight lessons the participation of the students was direct, at times really enthusiastic, by means of worksheets of increasing difficulty which aimed at the reading of the text through its gradual reconstruction.

Several difficulties had to be overcome: conceptual and linguistic. In the first half they were mainly conceptual owing to the complexity and the extent of the subject and the passages from Aristotle, Herodotus, Plutarch, Vitruvius, Proclus, Pappus, Eutocius, Euclid and others, whereas in the second half they were mainly linguistic because of the use of English and French texts, namely an XVIII-century French math text that students had to read without knowing French!

Students were given a questionnaire at the end of each lesson in order to check both their understanding and learning, and the teacher's clarity of exposition.

The workshop is meant to analyze in detail the above mentioned experience, and in particular:

1. to give reasons for
 - the choice of subjects in the general historical background;
 - the choice of M. de La Chapelle's book;
2. to explain
 - the guide-lines enabling students to read the French text;
 - the results of the questionnaires;
3. to present
 - a selection of the material produced by students;
 - a selection of the worksheets used in reading the French text.

Bibliography

- Apollonius, *Conics*, Encyclopaedia Britannica Inc., The University of Chicago, 1975
- M. de la Chapelle, *Traité des sections coniques, et autres courbes anciennes*,
Reproduction de textes anciens nouvelle série n.6 IREM, Paris VII, 1994
- Chasles, M., *Aperçu historique sur l'origine et le développement des méthodes en géométrie*, Reprinted by Gabay, Paris, 1989
- Coolidge, J. L., *A history of the conic sections and quadric surfaces*, Dover, New York, 1968
- Dedron, P., - J. Itard, J., *Mathematics and mathematicians*, 2 vols, The Open University Press, Milton Keynes, 1978
- van Eecke, P., *Les oeuvres complètes d'Archimède suivies des commentaires d'Eutocius d'Ascalon*, 2 vols, Blanchard, Paris, 1960
- Euclide, *Les Eléments*, vol. 1, vol. 2, puf, Paris, 1990, 1994
- Euclid (Heath, T. L. ed.), *The thirteen books of Euclid's Elements*, 3 vols, Dover, New York, 1956
- Heath, T. L., *A History of Greek mathematics*, 2 vols, Dover, New York, 1981
- Hoefer, F., *Histoire des mathématiques depuis leurs origines jusqu'au commencement du dix-neuvième siècle*, Hachette, Paris, 1879
- Pappus d'Alexandrie, *La collection mathématique*, 2 vols, Blanchard, Paris, 1982
- Proclo, *Commento al I Libro degli Elementi di Euclide*, Giardini, Pisa, 1978
- Proclus de Lycie, *Les commentaires sur le premier livre des Eléments d'Euclide*, Desclée de Brouwer, Bruges, 1948 (reprinted by the IREM of Lille)
- M. l'Abbé Sauri, *Institutions mathématiques, servant d'introduction à un cours de philosophie, à l'usage des Universités de France*, Valade, Paris, 1777
- Serenus d'Antinoe, *Le livre de la section du cylindre et le livre de la section du cone*, Blanchard, Paris, 1969
- Thomas, I., *Greek mathematical works*, 2 vols, Loeb classical library, W. Heinemann LTD, London, 1980

SOMANDO FRAÇÕES NO ÁBACO DOS ROMANOS E AUXILIANDO OS BABILÔNIOS EM DIVISÕES COM RESTO

Nilza Eigenheer Bertoni e Leda Maria Rangearo Fiorentini, Universidade de Brasília

Um Curso de Especialização em Ensino de Matemática, à distância, para professores da 5ª e 6ª séries (11-12 anos), está sendo desenvolvido na Universidade de Brasília. Uma questão que surge na capacitação de professores em ensino-aprendizagem da matemática é a relação do professor com a matemática, a qual engloba o nível e a natureza do conhecimento matemático do professor e a representação que faz dessa ciência. Essa questão é fundamental nos possíveis efeitos da capacitação sobre a prática docente, pois, embora o contacto com novas metodologias possa trazer ao professor insights sobre os conceitos abordados, elas podem não ser suficientes para remodelar a pré-concepção que ele tem da matemática.

A consideração desse quadro deu origem à nossa proposta de incluir, entre as quatro disciplinas do Curso de Especialização referido, uma intitulada "Entendendo a Lógica da Matemática - Tópicos Conceituais da 5a. e 6a. séries", cujos objetivos são o aprofundamento dos conhecimentos matemáticos relacionados aos tópicos do programa e a vivência de um novo olhar sobre essa matemática - aprofundamento no sentido de maior compreensão dos conceitos matemáticos, e de clareamento das relações existentes entre os mesmos. Nossos instrumentos para essa abordagem foram: a) a adoção de uma lógica calcada antes num rigor substancial do que num rigor formal, apta a explicitar a razão dos conceitos e processos numa linguagem de bom senso, ao invés de ocultar essa razão em formalismos herméticos ou em processos mecanizados; b) a retomada da linha histórica de desenvolvimento dos conceitos matemáticos, explicitando suas origens, finalidades, e as várias formas de registros pelas quais estes passaram em diferentes épocas e civilizações, convergindo entretanto para certos padrões universalmente aceitos; c) a teoria dos campos conceituais de Vergnaud (1991) e d) a concepção psico-sociogenética do conhecimento, que, levando em conta a articulação entre os aspectos cognitivo e social do desenvolvimento humano, centra-se num processo interacional de aprendizagem - aquele que considera não só os processos mentais, mas também o contexto sócio-histórico-cultural do indivíduo (Fávero, 1993). Nesse sentido a História da Matemática está fortemente presente nessa disciplina, permitindo evidenciar aspectos lógicos e interrelacionados do conhecimento, bem como a concepção psico-sociogenética do mesmo.

O programa envolveu aspectos da história dos números, de suas representações, operações e uso entre as civilizações antigas (de modo mais restrito, entre indígenas americanos, em particular do Brasil). Considerou-se essencial desafiar o aluno a buscar, através dos processos históricos, evidências da lógica dos procedimentos, chegando a uma descontextualização e abstração desse conhecimento.

Como exemplos de alguns aspectos desenvolvidos na disciplina, apresentaremos: operação com frações no ábaco dos romanos e passagem das frações à representação posicional (com vírgulas) em outras bases.

O ábaco dos romanos tinha hastes para as unidades, dezenas etc, divididas em duas partes: na inferior ficavam quatro contas e na superior apenas uma, representando cinco unidades da coluna correspondente. Havia ainda, à direita, duas hastes adicionais para frações. A primeira, junto à haste das unidades, era dividida em duas partes: a de baixo, com cinco contas, valendo $1/12$ cada uma e a de cima com uma conta valendo $1/2$. A última haste era dividida em três partes: a superior e a média, com uma conta cada, valendo $1/24$ e $1/48$; e a inferior com duas contas valendo $1/72$ cada uma. Com modelos desse ábaco os participantes deverão realizar somas e subtrações, usando equivalências e decomposições de frações. Por exemplo, para marcar $1/3 + 1/24$, basta marcar quatro contas de $1/12$ mais uma de $1/24$. Se a isso se quer adicionar $1/4 + 1/8 + 1/48$, vemos que $1/4$ deverá ser marcado como três contas de $1/12$, das quais aparentemente não dispomos, pois foram usadas quatro, sobrando apenas uma de $1/12$. Se pensamos, contudo, em adicionar esses $3/12$ aos quatro anteriores, obteremos $7/12$. Um desafio será o de lançar essa quantia no ábaco, o qual pode ser resolvido através da igualdade $7/12 = 1/2 + 1/12$. Continuando, devemos acrescentar $1/8$. Várias estratégias poderão surgir: pensar $1/8$ como $3/24$ ou como $1/12 + 1/24$. Podemos lançar $1/12$ mas não dispomos de contas de $1/24$. Novamente pensamos em adicionar esse $1/24$ ao que já foi marcado, obtendo $1/12$ - o que nos leva a desmarcar a conta de $1/24$ e marcar mais uma de $1/12$. Falta apenas marcar a última fração a ser adicionada, $1/48$, e isso pode ser feito diretamente. Ao todo, obtemos no ábaco $1/2 + 3/12 + 1/48$ ou $3/4 + 1/48$. Complementam cada atividade o refazer mental do cálculo e uma verificação através dos algoritmos atuais.

Para a segunda atividade devemos explorar inicialmente princípios da numeração babilônica, levando os participantes a constatarem que a casa à direita da casa das unidades corresponde a sexagésimos, a seguinte, a 3600-avos etc. Para escrever certa fração própria na notação posicional, deve-se verificar quantos 60-avos, quantos 3600-avos etc ela possui. Por exemplo, $1/3 = 20/60$, ou $0, \leftarrow \leftarrow$ (explicitando o zero e a vírgula que ficavam ocultos). Já $1/40 = 3/120 = 2/120 + 1/120 = 1/60 + 30/3600 = 0, \Upsilon \leftarrow \leftarrow \leftarrow$. Entretanto, já que no nosso sistema decimal podemos simplesmente dividir o numerador pelo denominador, não haveria um processo análogo entre os babilônios? Para resolver a situação devemos primeiro entender porque uma fração é igual ao quociente do seu numerador pelo seu denominador, e depois investigar a lógica do próprio algoritmo da divisão. Isso possibilitará a construção de uma lógica análoga para a divisão babilônica, generalizável, além disso, a um sistema posicional com base qualquer.

Bibliografia:

- BERTONI, Nilza Eigenheer. *Entendendo a lógica da matemática - tópicos conceituais de álgebra e geometria da 5ª e 6ª séries*. Curso de especialização à distância para professores de matemática do 1º grau. Projeto O professor em construção, SPEC. Universidade de Brasília (UnB).
- FÁVERO, Maria Helena (1993). *Psicologia do conhecimento*. Curso de especialização à distância para professores de matemática e de ciências do 1º grau.
- VERGNAUD, Gerard (1991). La théorie des champs conceptuels. *Recherches en didactique des mathématiques*, 10(23):133-169.

ALGORITHMES NUMERIQUES ET GEOMETRIQUES pour la résolution d'équations du second degré à trois termes.

O. Kouteynikoff, M. Grégoire, M. Hallez, Groupe M: A.T.H. IREM Paris VII.

Nous vous proposons quelques textes caractéristiques des imbrications possibles entre les démarches algébrique et géométrique.

A partir du IX^{ème} siècle et pendant tout le Moyen-Age, les mathématiques se développent sous la double autorité de Euclide comme maître à penser, et de Al-Khwarizmi, comme fondateur de l'algèbre. C'est dans ce contexte que le grand savant Al-Khayyam (1048-1139), produit de nombreux ouvrages, parmi lesquels Sur les démonstrations de l'algèbre et l'almuqabala (1074), dont nous lirons des passages: "une des notions mathématiques dont on a besoin dans la partie du savoir connue sous le nom de mathématique, est l'art de l'algèbre et de l'almuqabala, destiné à déterminer les inconnues numériques et géométriques." Les problèmes du second degré à trois termes, Al-Khayyam les classe et les résout numériquement à la manière d'Al-Khwarizmi (en écriture symbolique actuelle: $x^2+10x=39$; $x^2+21=10x$; $5x+6=x^2$). Dans le registre géométrique en revanche, il développe plusieurs démarches de portées différentes. Pour valider un algorithme numérique, il reconnaît sur la configuration géométrique associée au problème, les conditions d'application de l'une des propositions II,5 ou II,6 des Eléments d'Euclide. Al-Khayyam se pose aussi le problème de construire la grandeur géométrique cherchée, soit qu'il se ramène à un problème d'application d'aire: application d'une aire donnée sur un segment donné avec défaut ou excès d'un carré; le problème est résolu par Euclide au livre VI, propositions 27 à 29. Soit que, pour la résolution géométrique d'une équation de la troisième espèce, il ne se contente des moyens élémentaires que sont les propositions I,47 et II,14. Al-Khayyam calcule la solution numérique et construit la solution géométrique. Plus de cinq siècles avant Descartes, il donne le même statut aux deux inconnues.

Quand en Europe au XV^{ème} siècle, les traductions en latin des Eléments se répandent, la tradition mathématique grecque se trouve renforcée. Au moment où l'algèbre commence à évoluer grâce au passage progressif de l'expression rhétorique à l'expression syncopée, au moment où les nombres négatifs font leur apparition, la référence obligée à Euclide prend des formes différentes selon les auteurs.

Nous vous proposons quelques textes de la Renaissance. Dans son Grand Art ou partie cachée des nombres...(1577), Gosselin, soucieux de n'opérer que sur des nombres positifs, classe encore les équations quadratiques en trois espèces à la manière des Arabes. Il a adopté une notation symbolique à connotation géométrique: Q pour le carré de l'inconnue, L pour l'inconnue, côté du carré; il utilise les signes P et M pour *plus* et *moins*, mais écrit *égal* en toutes lettres. Pour chaque type d'équation, il mène deux procédures distinctes. La première algorithmique classique; la seconde est annoncée comme une "démonstration arithmétique" Elle concerne une équation particulière. L'inconnue L est remplacée par sa valeur A, le carré Q par sa valeur A fois A. Et Gosselin calcule. Par des transformations astucieuses, il atteint la solution, soit en arrivant à l'égalité de deux carrés, soit en se ramenant à un problème qu'il a déjà traité. La "démonstration arithmétique", c'est-à-dire les démarches calculatoires sont justifiées par des

propositions géométriques du livre II des Eléments, souvent appelé, depuis le XIX^{ème} siècle, le livre de "l'algèbre géométrique".

Quelques années auparavant, l'Allemand Stifel a fait oeuvre originale en publiant son Arithmetica Integra(1544). Il y fait la synthèse des connaissances de son époque en arithmétique et en algèbre, qu'il augmente de contributions personnelles. Stifel a adopté l'usage des nombres négatifs et mis en place un système de notations pour l'inconnue et ses puissances: $1x$ pour la coss, $1z$ pour son carré... Pour la résolution d'un problème, il procède à la mise en équation, puis isole le terme de plus haut degré dans un membre de l'équation, et rend par division son coefficient égal à 1. Stifel classe les équations quadratiques en trois catégories en fonction des signes des coefficients: $1z \text{ eq } 84-8x$; $1z \text{ eq } 8x+48$; $1z \text{ eq } 18x-72$. La résolution d'un problème du second degré se ramène donc à l'extraction d'une racine carrée: $1x \text{ eq } \sqrt{84-8x}$. Stifel ne calcule que les racines positives. Cherchant une procédure calculatoire commune aux trois types d'équation, et devant donc tenir compte des signes des coefficients, il élabore un algorithme positionnel en cinq points, les résultats successifs étant inscrits de façon réglée dans l'une ou l'autre des colonnes définies par les deux coefficients. Si ce progrès algébrique considérable ne rend pas Stifel indifférent à la géométrie euclidienne, l'intérêt de sa démarche géométrique ne réside pourtant plus dans les illustrations d'algorithmes qu'il propose encore quand elles sont immédiates. La représentation discrète des nombres qu'il adopte lui permet de jouer avec les nombres et particulièrement, en se fondant sur des propositions du livre II des Eléments d'Euclide, de fabriquer des équations. C'est le rôle de la géométrie tel qu'il l'explicite au livre III de l'Arithmetica Integra.

Quand Stevin publie son Arithmétique, en 1585, il est au fait des derniers développements de l'algèbre de cette fin de siècle. Il utilise la notation exponentielle pour les puissances de l'inconnue. S'il propose une équation du second degré à résoudre, il demande, par exemple, pour quelle valeur de $1 \textcircled{1}$, $1 \textcircled{2}$ vaudra $4 \textcircled{1} + 5$ ou $4 \textcircled{1} + 5 \textcircled{0}$. Il calcule avec la même aisance sur tous les nombres positifs, négatifs, irrationnels, mais ne recherche toujours que les racines positives. Il applique à tous les problèmes du second degré l'algorithme de résolution numérique de Stifel, allégé par l'adoption de la présentation unique $\textcircled{2}$ vaut $\textcircled{1}\textcircled{0}$. Comme Bombelli (Algebra, 1572), il justifie algébriquement l'algorithme de résolution numérique. Quel est donc le rôle de la géométrie dans cette situation algébriquement heureuse? Examinons le plan d'étude repris pour chaque équation. D'abord une "construction": c'est le terme géométrique que Stevin utilise pour désigner l'algorithme numérique. Ensuite une "démonstration arithmétique": c'est une simple vérification par calcul. Puis une "démonstration géométrique" en deux temps marqués par Stevin: celui de la mise en place de la configuration géométrique type associée au problème et celui d'une "construction par les grandeurs", qui... ne construit pas la grandeur inconnue. Quand Stevin construit la somme d'un petit carré et d'un rectangle et obtient un grand carré, c'est que le rectangle est transformable en un gnomon qui s'adapte au petit carré. Cela ne se produit que dans la configuration de la proposition II,6 des Eléments. De même ce n'est que dans la configuration propre à la proposition II,5 qu'on peut obtenir un petit carré en retranchant un rectangle d'un grand carré. Que sont donc ces "constructions par les grandeurs", ces algorithmes géométriques que nous propose Stevin? Ce sont des arguments en faveur de sa thèse de l'analogie entre les quantités arithmétiques et géométriques... .

Sessions of HEM Braga 96 without texts included in these proceedings
Séances de HEM Braga 96 dont les textes ne sont pas inclus dans les actes
Sessões do encontro HEM Braga 96 cujos textos não estão incluídos nestas actas

Introductory lectures • Conférences introductives • Conferências introdutórias

- IL04: *A Survey of Greek Mathematics*
Frederick Rickey, Bowling Green State University, U.S.A
- IL17: *Histoire des Probabilités*
Anne Boyé, IREM de Nantes, France
- IL18: *The role of Proof*
Jesús Hernández, Universidade Autónoma de Madrid, Espanha
- IL19: *Logic and Set Theory*
Alejandro R. Garciadiego, Universidad Nacional Autónoma de México, México
- IL27: *Notes on the History of Mathematics and the History of Art for the classroom*
Florence Fasanelli, Mathematical Association of America, USA

Workshops • Ateliers • Sessões Práticas

- W01: *El proyecto "Helena": una experiencia interdisciplinar de Historia de la Matematica llevada en aula*
Agustín Isidro de Lis, all members Orotava, I. B. Villalba Hervás - Sem. OROTAVA, Espanha
- W04: *Navegações portuguesas e matemática*
Ana Vieira, Esc. Sec. de Linda a Velha; Eduardo Veloso, Universidade de Lisboa, Portugal
- W06: *A Geometria das Áreas*
Carlos Manuel M. Correia de Sá, Universidade do Porto, Portugal
- W09: *The History of Mathematics through activity based learning*
David Lingard, Sheffield Hallam University Centre for Mathematics Education, UK
- W10: *Moments mécaniques d'Archimède à Poinsot*
Dominique Benard; Monique Nouet, IREM le Mans, France
- W13: *Regula falsi: some reactions of elementary school teachers*
Greisy Winicki Landman, Dep. of Education in Technology and Science - Technion, Israel
- W14: *Problemas antigos na sala de aula*
Isabel Cristina Dias, Escola Secundária Santo António dos Cavaleiros; Maria João Furtado Rita Lagarto Escola Secundária do Monte da Caparica, Portugal
- W15: *O uso de exemplos com história na aula de matemática*
Jaime Carvalho e Silva, Universidade de Coimbra, Portugal

- W16: *Indian Mathematics in the Context of the Vedic Sacrifice (Sulbasūtra)*
Jean Michel Delire, Université Libre de Bruxelles, Belgique
- W17: *Chaos in the Classroom*
June Barrow-Green, The Open University, UK
- W18: *Mathematics in Ancient China*
Man-Keung Siu, University of Hong-Kong
- W19: *As origens do sistema de numeração decimal*
Maria Fernanda Estrada, Universidade do Minho, Portugal
- W20: *A resolução de equações na Álgebra de Pedro Nunes*
M^a Gertrudes Soares de Oliveira, Esc. Sec. de Sta. Maria da Feira, Portugal
- W21: *Using Ancient Board Games to Enhance the Middle School Mathematics*
Mary Sue Houston, Warrenton Middle School, Virginia, USA
- W22: *Babylonian Mathematics in the Classroom*
Anko Haven, The Netherlands
- W23: *History of Combinatorics*
Robin J. Wilson, The Open University, UK
- W25: *O ensino da trigonometria baseado no Almagesto*
Maria José Mendes da Costa, Esc. Sec. Augusto Gomes, Matozinhos, Portugal
- W26: *How to integrate the history of mathematics in the education of teachers : some examples.*
M. G. Koen M. Pillot, Katholieke Leergangen, Tilburg, Holland. (Teacher training college)
- W27: *Developing mathematical ideas by exploring weaving board*
Marcos Cherinda, Universidade Pedagógica, Moçambique
- W28: *Moons, bows and barges: some Old Babylonian geometrical shapes*
Eleanor Robson, Oxford University, UK
- W30: *Échanges sur des projets interdisciplinaires autour de l'histoire des mathématiques*
Caroline Dulac-Fahrenkrug; Christine Proust; Maryvonne Hallez; Michèle Grégoire, IREM, Histoire des Maths, France
- W32: *Da matemática à música: um passeio numérico através dos sons*
Oscar João Abdounur, Universidade de S. Paulo, Brasil
- W33: *Infinite series in South India mathematics*
P. Rajagopal, York University, Canada

Sponsors • Commanditaires et parrains • Patrocínios e apoios

Adega Cooperativa de entre Braga e Cávado
Adega Cooperativa de Monção
Adega Cooperativa de Ponte da Barca
Adega Cooperativa de Vila Verde
Câmara Municipal de Barcelos
Câmara Municipal de Braga
Câmara Municipal de Guimarães
Câmara Municipal de Terras do Bouro
Centro de Informática da Universidade do Minho
Comissão Nacional para as Comemorações dos Descobrimentos Portugueses
Companhia de Seguros Bonança - Grupo BCP
Departamento de Física da Universidade do Minho
Empresa de Águas do Fastio
Feira Nova - Hipermercados, S.A.
Fundação Calouste Gulbenkian
Fundação Oriente
Governo Civil de Braga
Grupo Jolima
Grupo de Estudos de Matemática e Ciência da Computação
Instituto da Cooperação Portuguesa
Instituto de Inovação Educacional
IPPAR- Paço dos Duques de Bragança
Irmandade de N. Sra. da Penha
Labruge - Indústria de Carnes
Móveis Soares Barbosa
Moutados - Indústria de Carnes
Museu D. Diogo de Sousa
Parque Nacional da Peneda Gerês
Posto de Turismo de Braga
Quinta do Minho
Região de Turismo do Alto Minho
Região de Turismo Verde Minho
Reitoria da Universidade do Minho
Segrafedo Zanetti
Sociedade Martins Sarmiento
Sociedade Portuguesa de Matemática
Turipenha
Unesco
Unicer, União Cervejeira SA

List of participants • Liste des participants(tes) • Lista dos(as) participantes

Algérie

Rachid Bebbouchi, Institut de Mathématiques - USTHB, BP 32 El-Alia, 16111 Alger, Algérie

Sadallah Boubaker, Dep. de Mathématiques, E.N.S. B.P. 92, 16050 Kouba, Algérie

Youssef Guergour, Département des Mathématiques, E.N.S. B.P. 92, 16050 Kouba, Algérie

Australia

Gail Fitzsimons, 34, The Boulevard, Warrandyte, 3113 Victoria, Australia

Ian Algernon Isaacs, Faculty of Education, Northern Territory University, Darwin 0909, NT, Australia

Robert P. Sullivan, Mathematics Dept, University of WA, Nedlands 6901, Australia

Vivienne Willis, 34, Lake Road, Blackburn, Victoria, 3130, Australia

Austria

Weinkamer Erich, Imbergstrasse, 17, A-5020 Salzburg, Austria

Bélgique

Jean Doyen, Dépt. Maths, Campus Plaine CP 216, Univ. Libre de Bruxelles, Bld. du Triomphe, B-1050 Bruxelles, Belgique

Bélgique

Jean Michel Delire, Rue de la Levure, 5, 1050 Bruxelles, Belgique

Marie-Jeanne Gaspard, 21/11, Avenue des Vaillants, 1200 Bruxelles, Belgique

Paul Van Praag, Av. Vander Swaelmen, 8, 1170 Bruxelles, Belgique

Brasil

Adelina Marta de Souza Miranda, Quadra 02 Conjunto E2, Casa 05 - Sobradinho -DF, 73015-020, Brasil

Adriana Aparecida Barbosa Ramos, Quadra 04 Conjunto I casa 13 -Planaltina- D.F., 73330-040, Brasil

Ailton Paulo de Oliveira Júnior, CNB1 - Lote 12 - APT. 904, 72.115-015 - Taguatinga - DF, Brasil

Alexander Benedikt Meyknecht, Rua Campos Salles, 485-161 Suzano -São Paulo, 08674-020, Brasil

Alexandre Vinicius Campus Damasceno, Av. Marquês de Herval, 717 - Casa 04, 66085-310, Brasil

Ana Luiza Federighi Chamizo Silva, Quadra 06 CL 13 - Ap.101 - Sobradinho - D.F, 73005-080, Brasil

Antônio José Lopes, Caixa Postal 11277, 05422-970, Brasil

Antônio Miguel, Rua Jader Passos, 374 - casa 37 - Campinas - SP, 13091-550, Brasil

Ariovaldo Antônio Zaniratto, Av. Nami Azém, 871 - Jundiá, 13219-610 São Paulo, Brasil

Arlete de Jesus Brito, R. Clélia, 891 - Ap. 22, 05042-000 São Paulo, Brasil

Bongiovanni Vincenzo, Rua Coronel Pedro Arbues, 163 - Santos S. Paulo, CEP: 11035-050 BRASIL, Brasil

Celso de Oliveira Faria, Av. Tocantins, 251 apt. 602 Ed. Tocantins - Centro - Goiânia, 74015-010, Brasil

Circe Mary Silva da Silva Dynnikov, R. Amélia Tartuce Nasser, 425 - Ap.203 Vitoria, 29065-020, Brasil

Dario Fiorentini, Rua Thomas Alberto Whatelly, 123 - Campinas-SP, 13089-380, Brasil

Dulce Monteiro Rei, Rua Herotides de Oliveira, 29 Apto 801, 24. 230-230 Niterói - RJ, Brasil

Edilma de Freitas Ferreira, QNG 30 - Casa 30, 72.130 - 300 Taguatinga - DF, Brasil

Edna Rodrigues da Rocha, Quadra 3, Bloco O, apt.202 - SRL - Planaltina, 73350-030, Brasil

Eduardo Sebastiani Ferreira, Av. Morais Sales, 1027 - Apt 73, 13010-002 Campinas SP, Brasil

Elaine Vieira, Av. Lucas de oliveira 1960/apt. 1402 -Porto Alegre, Rio Grande do Sul 90460-000, Brasil

Elisabeth Cristina de Faria, Rua 262, Quadra 111, lote 02 Setor Universitário, Goiânia, 74615-300, Brasil

Elsa Alice Ledur, Rua São Joaquim, 436 - apt. 603 - Centro São Leopoldo, RS 93010-190, Brasil

Erci Alves Dutra, QNM 25, Conj F - Casa 18, 72.215-250 Ceilândia Sul - DF, Brasil

Eronaldo Soares de Almeida, Av. João Ispere Gebrina, 419 Formosinha - Formosa - GO, 73800-000, Brasil

Eurico Lanz, Rua Guajuvira, 514 - Novo Hamburgo - RS, 93520-200, Brasil

Eurípedes Alves de Paula, Ed. Esmeralda, Apto 102B - Av. T-11, 2572 S. Buleno, 74223-070 Goiânia GO, Brasil

Fábio Kruse, Rua Tapes, 1200/27 - Novo Hamburgo - RS, 93320-080, Brasil

Francisca Maria Paes, QNL 05 Conjunto D - Casa 08, 72.150 - 050 Taguatinga - DF, Brasil

Helton Euprosino Niquini, SHTS C.J. A - Area Isol - LagoSul - CP 7077, 71-619-970 Brasília, Brasil

Iara Helena Quinto Lanz, Rua Guajuvira, 514 - Novo Hamburgo - Rio Grande do Sul, 93520-200, Brasil

Inês Lopes Hott, Quadra 04 Conjunto F - Casa 34 - SRL - Planaltina, 73350-040 DF, Brasil

Iran Abreu Mendes, R. Jundiá, 783 - Apto 301, 59020-220, Brasil

Jaciane Rodrigues de Sousa, Conjunto Tapajus, Rua Alaska, 52, 73000-000 Icoaraci - Belém - Pa, Brasil

Jesiel Crisóstomo dos Santos, CSB 03 - Lote 05 - Ap. 410, 72.015 - 535 Taguatinga Sul - Comercial Sul, Brasil

John Andrew Fossa, Caixa Postal 1631 - Campus Universitário, 59.072-970 - Natal, RN, Brasil

José Roberto Boettger Giardinetto, Rua Paulo Eiró, 529 - apto 302 bloco 06, Presidente Prudente - S.P. - 19023-640, Brasil

Brasil

Julia Hennemann, Rua Cristovão Colombo, 685 - Novo Hamburgo RS, 93310-320, Brasil

Lígia Arantes Sad, Av. 4 - A, 249 - Cidade Nova - Rio Claro - SP, 13506-776, Brasil

Lúcia Inês Alves de Araújo, Quadra 16 Conjunto E, Casa 13 - Sobradinho-DF, 73050-160, Brasil

Luiz Antonio Ponce Alonso, Av. Washington Luis, 309 - Apto 31, 110055-001 Santos - SP, Brasil

Marcos Vieira Teixeira, Rua 4, 555 - Apt. 63 - Rio Claro, 13 500 912 São Paulo, Brasil

Marger da Conceição Ventura Viana, Sftio do Tanque/Cachoeira do Campo/Ouro Preto, 35.410.000 MG, Brasil
 Maria Bethânia Sardeiro dos Santos, Rua AP01 Q.03 L.21 Orunã III, 74740360 Goiânia - Goiás, Brasil
 Maria de Oliveira Vaz, Rua 2, 438 Vila Pai Eterno - Trindade - Goias , 75380-000, Brasil
 Maria Helena Selbach Enriconi, Rua Veronese, 45 Apt.401 Porto Alegre RS, 91060-190, Brasil
 Maria Regina Gomes da Silva, Rua Anchieta, L-4, Cx. P. 65, 17490 - 000 Piratininga - SP, Brasil
 Maria Terezinha J. Gaspar, SQN 206 Bloco B apt. 205 P, 70844-021, Brasil
 Marilene Oliveira da Silva, QNN 10, Conjunto B - Casa 05, 72.220 - 100 Ceilândia - DF, Brasil
 Marifeusa Fernandes de Alvarenga, Quadra 11, Conjunto B, casa 4D - Sobradinho- DF, 73040-110, Brasil
 Matheus da Rocha Grasseli, R Oscar Freire, 1218 Apto 23 - S.Paulo , 01426/000 Sao Paulo, Brasil
 Melquisedec Francisco da Silva, Av. João de Camargo, 510 - Santa Rita do Sabucal, 37540-000 Minas Gerais, Brasil
 Miriam de Araújo Alves, Quadra 16, Conjunto L, casa 12 - Sobradinho -DF, 73050-160, Brasil
 Nilza Eigenheer Bertoni, SQS 211 Bloco G ap-301, 70274-070, Brasil
 Niva Helena Bonenberger, Rua Voluntários da pátria, 200 - Nova Hamburgo - RS, 93410-090, Brasil
 Olímpio Rudinin Vissoto Leite, Rua Rio de Janeiro, 27 - Santos - SP, 11075-340, Brasil
 Oscar João Abdounur, R. Bartolomeu Zunega, 84 Casa 8 Pinheiros, 05426 020, Brasil
 Paulo Sérgio Tavares da Costa, QNG 22 Casa 12 - Taguatinga - DF, 72.130 - 220, Brasil
 Perpétua Auxiliadora Lima solino, Quadra 14, Cojunto B-8, Casa 12 - Sobradinho - DF, 73050-140, Brasil
 Renato Sardinha de Sousa, Rua C-194, Qd 492, Lt 10 - Jardim América, 74.270-130 Goiânia - Goiás, Brasil
 Renilda da Costa Xavier, SQN 313 - Bloco B - Apartamento 310, 70.766 - 020 Brasília - DF, Brasil
 Robson André Barata de Medeiros, Tv. Eunice Weaver, 116 , 68083-290 Sacramenta - Belém - PA, Brasil
 Seiji Hariki, Rua Francisco Leitão, 678 - Ap. 92, 05414-020 São Paulo, Brasil
 Sergio Nobre, Avenida 4 A, 1382 - Bela Vista - Rio Claro, 13 506 070 São Paulo, Brasil
 Shirlei Lins Conceição, QNA 54 - Casa 20, 72.110 - 540 Taguatinga - DF, Brasil
 Silmara Epifânia de C. Carvalho, Avenida Pedro P. Souza, 10875, Goiania 2, 74663-520 Goiânia-Goiás, Brasil
 Sylvania Regina Costa Dutra da Silva, Rua Santa Rosa, 130, Bl. A, apt. 202 - Niterói, 24220-420 Rio de Janeiro, Brasil
 Ubaldo Luiz Ribeiro da Fonseca, QNA 27 - Casa 12, 72.110-270, Brasil
 Ubiratan D'Ambrosio, Rua Peixoto Gomide, 1772 - Apto 83, 01409-002 São Paulo SP, Brasil
 Virgínia Cardia Cardoso, Av. Pompéia, 249 - Apto. 22-B, SP 05023-000 - São Paulo, Brasil
 Wanderson Finotti Silveira, Rua Armogaste da Silveira, 505 - Sector Marchal Rondon, 74.560-020 Goiânia - Goiás, Brasil
 Wesley Chaves, Rua Princesa Isabel, 221, 74.420-160 St. Rodoviário, Brasil
 Zaira da Cunha Melo Varizo, Rua 15, 1770, Setor Marista, 74150-150, Brasil

Cabo Verde

Maria das Dores Almeida de Moraes, Bloco B1, 2º Esq. - Achada Stº António, 72 - A Praia, Cabo Verde
 Paulino Lima Fortes, C.P. 279 - Instituto Superior de Educação, Praia, Cabo Verde

Canada

Louis Charbonneau, Dept. Math., V.Q.A.M., C.P. 8888, Succ. A, Montréal, H3C 3P8, Canada
 Luis Radford, Université Laurentienne, Sudbury, P3E 2C6 Ontario, Canada
 P. Rajagopal, Atkinson College, York University
 4700 Kelle st., North York Ontario, M3J1P3, Canada
 Philippe Baille, Royal Military College, Kingston, Ontario, K7K 5L0, Canada
 R. Godard, 92, Florence Street, Kingston, Ontario K7MIY6, Canada
 Stephen Campbell, 3012, Hamilton Hall - Burnaby, B.C., V5A 1S6, Canada

Colômbia

Luis Carlos Arboleda Aparicio, Universidad del Valle, Apartado Aereo 25 360, Cali, Colômbia

Denmark

Christian Thybo, Norregade 49, 2 Th., DK - 7700 Thisted, Denmark
 Torkil Heiede, Dept. of Math., Royal Danish School of Educ. Studies Emdrupveg 115 B, DK-2400 Copenhagen NV, Denmark

Egypt

Maassouma Kazim, 5, Said Bahgat St., Heliopolis, Cairo, Egypt

Espanha

Agustín Isidro de Lis, C/ Chopo, 26 - La Laguna, Tenerife - Canarias, Espanha
 Antonio J. Duran, Universidade de Sevilha; Dep. de Matematica/ Apartado 1160, 41080 Sevilla, Espanha
 Carlos Mederos Martin, Avda Lora Tomayo, 42 - Portal A - 1º - 5, 38205 La Laguna, Espanha
 Dolores Carrillo Gallego, Avd. Isaac Peral, 16 - 2º E, 30007 Murcia, Espanha
 Jesus Hernández, Rafael Herrera, 11 - AP 613, 28036 Madrid, Espanha
 José Gatass Filho, Colegio Mayor - Casa do Brasil, Av. Arco de la Victoria, 20040 Madrid, Espanha
 José Luis Montesinos Sirera, I. B. Villalba Hervás - Urb. Carmenaty S/N, 38300 Laoratava - Tenerife, Espanha
 Jose Manuel Mira Ros, Avd. Isaac Peral, 16 - 2º E, 30007 Murcia, Espanha
 Maria Jesús Pérez Martin, Calle Calvario, 223, 38350 Tacoronte - Tenerife, Espanha

Mariano Martínez Perez, Universidade Complutense de Madrid, Facultad de Matemáticas, Dep. de Algebra, 28040 Madrid, Espanha

Pedro J. Hernández González, Peral 7, 38400 Puerto de la Cruz, Espanha
France

Alain Bernard, 35, Chemin des Mas, 30620 Aubord, France

Anne Boyé, 9, avenue des Muriers, 44500 La Baule, France

Annick Massot, 12, Rue Saint-Saens, 44470 Carquefeu, France

Bernard Hebraud, 21, Avenue Jean Camp, 11100 Narbonne, France

Brigitte Amélie Malinaud, 72, Rue de Charonne, 75011 Paris, France

Caroline Dulac-Fahrenkrug, Le Cédre Bleu, A113 - 34, Rue de Geneve, 01210 Ferney-Voltaire, France

Christian Massot, 12, rue Saint-Saëns, 44470 - Carquefou, France

Christine Proust, 3, Rue de Richelieu, 75001 Paris, France

Claude Merker, Rue de la Bascule, 25170 Chaucenne, France

Dominique Benard, IREM - Université du Maine - Le Mans, 72017 Le Mans Codex, France

Eliane Cousquer, 1, Rue des Tilleuls, 59152 Chérens, France

Evelyne Barbin, 17 Rue Loubet, 93200 Saint-Denis, France

Haron Gerard, 42 rue P. Lebon - Rennes, 35000 Rennes, France

Henri Lombardi, 49 Rue des granges, 25000 Besançon, France

Hombeline Languereau, 13, Rue Ledoux, 25000 Besançon, France

Jacqueline Guichard, Le Chemin Vert, Le Tallud, 79200 Parthenay, France

Jacques Borowczyk, 24, Rue Marcel Tribut, 37000 Tours, France

Jean-Claude Diebolt, La Foucherie - La Fresnaye sur Chedouet, 72600 Mamers, France

Jean-Luc Dorier, 10, Rue des Bains, 38000 Grenoble, France

Jean-Luc Verley, 16, Rue de Turbigo, 75002 Paris, France

Jean-Paul Guichard, Le chemin Vert, Le Tallud, 79200 Parthenay, France

Jean-Paul Ranquet, 3, Rue du pic d'Aniê, 64400 Oloron, France

Jean-Pierre Escofier, Av. de Moreton Hamstead, 35830 Betton, France

Marie Josée Hebraud, 21, Avenue Jean Camp, 11100 Narbonne, France

Marie-José Durand-Richard, 33, Rue des Lilas, 75019 Paris, France

Martine Janvier, 7, Rue du Petit Saint-Pierre, 72000 Le Mans, France

Maryvonne Hallez, 6, Rue Boissonade, 75014 Paris, France

Michèle Grégoire, 32, Rue Gandon, 75013 Paris, France

Monique Nouet, 11, Rue Jaques Barcat, 72000 Le Mans, France

Odile Kouteynikoff, Les Millepertuis Bat C2, 91940 Les Ulis, France

Patrice Johan, 7, Impasse du four, 94 880, France

René Guitart, 10 Rue Bonnevide, 93200 Saint-Denis, France

Sylvie Raudrant, 3, Rue de La Houn - Clas Montalibet, 64300 Orthez St^a Suzanne, France

Teresa Maria dos Reis Assude, 336E, Ch. Barthélémy Florent, 83200 Toulon, France

Xavier Lefort, Les Sables - Avenue des Jaunais, F44380 Pornichet, France

Yves Ducel, Résidence Le Rimbaud - 3A, Rue du Refuge, F - 25000 Besançon, France

Rudolf Bkouché, 64 rue Negrier, 59800 Lille, France

Germany

Gert Schubring, Institut für Didaktik der Math. - Universität Bielefeld, PF 100131, D-33501 Bielefeld, Germany

Harald Groppe, Mühlingstr. 19, D - 69121 Heidelberg, Germany

Michael Otte, Institut für Didaktik der Math, Univ. Bielefeld, Postfach 1001, D- 33501 Bielefeld, Germany

Peter Brosche, Observatorium Hoher List der Universitäts-Sternwarte - Bonn, D-54550 Daun, Germany

Uwe Gellert, Freie Universität Berlin, FB 12 WE02, Habelschwerdter Allee 45, D-14195 Berlin, Germany

Greece

Constantinos Tzanakis, 60, Karterou Str, 71201 Iraklion - Crete, Greece

Hong Kong

Chun-ip Fung, The Hong Kong Institute of Education, Northcote Campus - 21 Sassoon Road, , Hong Kong

Man-Keung Siu, Department of Mathematics, University of Hong Kong - Pokfulam Road, Hong Kong, Hong Kong

Israel

Amira Cooper, 23, Stephan Weise, 35439 Haifa, Israel

Greisy Winicki Landman, Department of Education in Technology & Science - Technion, 32000 Haifa, Israel

Moshe Cooper, 23, Stephan Weise, 35439 Haifa, Israel

Shmuel Avital, Department of Education in Science, The Technion City, Haifa 32000, Israel

Italia

Clara Silvia Rocero, Dipartimenti di matematica, Via C. Alberto, 10, Torino 110123, Italia

Franco Favilli, Dipartimento di Matematica - Via Buonarroti, 2 Pisa, 56100 Pisa, Italia

Fulvia Furinghetti, Dipartimento di Matematica, Via Dodecaneso, 35, 16145 Genova, Italia

Giuliano Testa, Borgo Casale, 76, 36100 Vicenza, Italia
 Grazia Indovina, Viale delle Magnolie 21, 90144 Palermo, Italia
 Guido Osimo, Istituto di Metodi Quantitativi- Universita' Bucconi - Via Gorbi 5, 20100 Milano, Italia
 Jama Musse Jama, Via di Pratale, 103 F, 56100 Pisa, Italia
 Livia Giacardi, Dipartimenti di Matematica, Via C. Alberto, 10, Torino I10123, Italia
 Maria Fernanda Farina, Via G. Lengaretti 59 Rende(CS), Cosenza, Italia
 Misso Paola, Dipartimento de Matematica e Applicazioni, 90123 Palermo, Italia

Japan
 Osamu Kota, 3-8-3, Kajiwara, Kumakura, 247 Kanagawa-Ken, Japan

Malaysia
 Mohaini Mohamed, Math, Science & Computer Dept. Faculty of Education, Universiti Teknologi, K.B. 791 80990, Johor, Malaysia

Mauritania
 Mohamed Ahmed Ould Sidaty, Ecole Normale Supérieure de Novakchott, B.P. 990, Mauritanie
 Ould Jidoumou Ahmedou, Ecole Normale Supérieure de Novakchott, B.P. 990, Mauritanie

México
 Alejandro Garciadiego Dantan, José M. Velasco #71, San José Insurgentes, 04510 Mexico, D.F., México
 Guillermina Waldegg, Gómez Farfás, 74 - Coyoacán - México D. F., 04100, México
 Luis Moreno-Armella, Dakota 379, Col. Nápoles - México D. F., 03810, México

Moçambique
 Abdulcarimo Ismael, Departamento de Matemática, Universidade Pedagógica
 C.P. 4040, Maputo, Moçambique
 Anatoli Gorban, Dep. de Matemática e Informática, UEM, Maputo C.P. 105, Moçambique
 Marcos Cherinda, Departamento de Matemática, Universidade Pedagógica
 C.P. 4040, Maputo, , Moçambique
 Paulus Gerdes, Universidade Pedagógica
 C.P. 3276, Maputo, , Moçambique

Norway
 Jean-Paul Ginestier, Red Cross Nordic - United World College, 6820 Flekke, Norway
 Otto B. Bekken, Torsvikleiva 12, 4637 Kristiansand, Norway

New Zealand
 Coralie Daniel, Dep. of Maths & Statistics, University of Otago, P.O. Box 56, Dunedin, New Zealand
 Michael R. Carter, Department of Mathematics, Massey University - Private Bay 11222, 5301 Palmerston North, New Zealand

Papua New Guinea
 Indira Chacko, University of Papua New Guinea, Goroka Campus, P.O. Box 1078 - Goroka, Papua New Guinea

Portugal
 Aida Maria Ferreira Carreira, Rua 13 de Dezembro - Vivenda Pereira - Catujal, 2685 Unhos, Portugal
 Alcides José dos Prazeres Caetano, R. Timor, Lote 129 - 3ºD - Olival Basto, 2675 Odivelas, Portugal
 Alcina Elisa Gomes Teixeira Rua Fonseca, Rua 9 de Abril, 660 - 1º Esq. H, 4200 Porto, Portugal
 Alexandra Manuela e Sousa da C. Machado Martinho, Av. D. João IV, Ed. Vila Verde, Bloco B2 - 4º Esq, 4810 Guimarães, Portugal
 Amélia Cristina Duque Caldeira, R. do Professor Carlos Lima, 4100 Porto, Portugal
 Amélia Maria Braga da Cruz Melo Guerreiro, Rua S. Domingos, 108 - 1º Dto, 4710 Braga, Portugal
 Ana Dulce Lopes Gomes, Av. Dom João IV, 583 - 4º, 4800 Guimarães, Portugal
 Ana Emília dos Santos Nogueira, Rua do Outeiro, 4405 Vila de Canelas, Portugal
 Ana Filipa Baluga Coelho Guerreiro, Rua dos Soeiros, 313 - 8º D, 1500 Lisboa, Portugal
 Ana Isabel Rodrigues da Silva Rosendo, R. Virgílio Correia, Lote 12/13 - 4º Dto, 3000 Coimbra, Portugal
 Ana Luisa Ferreira Canelhas Correia, R. Sargento Jácome Moreira, 9 - 1º Dto, 1300 Lisboa, Portugal
 Ana Maria de Oliveira Mendes, Travessa do Nogueira, 8 - R/C B, 9050 Funchal, Portugal
 Ana Maria Ferreira Cardoso, Quinta do Mendes, Lote 89 - 2º Dto, 2675 Odivelas, Portugal
 Ana Maria Leitão Bandeira Pires Machado Rodrigues, Apartado 101, 5300 Bragança, Portugal
 Ana Maria Martins Rodrigues, Rua São Domingos, 152 - 3º Dto, 4710 Braga, Portugal
 Ana Maria Pacheco Freire de Matos Pacheco, R. Nossa Senhora da Esperança, 2, 6250 Belmonte, Portugal
 Ana Maria Prudêncio Vieira, Rua José Duro, 3 - 2º Dtº - Algés, 1495 Lisboa, Portugal
 Ana Maria Sousa Almeida, R. Nova do Seixo, 535 - Senhora da Hora, 4450 Matosinhos, Portugal
 Ana Maria Viegas de Brito Jorge, R. Dr. Mário Vasconcelos e Sá, 2 - 4º D, 4050 Porto, Portugal
 Ana Paula de Seixas Mourão, Rua Cândido de Oliveira, 62 - 4º Esq, 4710 Braga, Portugal
 Ana Paula Ferreira Matos Costa Cunha, Urb. Eng. Mário Valente, Casa 24, 4820 Fafe, Portugal
 Anabela Lopes Duarte, Rua dos Congregados, 8 - 5º Dto, 4710 Braga, Portugal
 Anabela Moreira Gaio, Escola C+S de Ferreira do Zezêre - Rua Francisco Keill, 2440 Ferreira do Zezêre, Portugal

Anabela Souza Moniz, Rua Serpa Pinto, 203, 4820 Fafe, Portugal
 André Manuel Gomes de Matos, Lugar do Monte - Lamações, 4710 Braga, Portugal
 Ângela Maria Lima Soares, Rua Camilo Oliveira, 5 - R/C Esq., 4435 Rio Tinto, Portugal
 Angela Maria Pinto do Couto, Rua 7, 475 - 2º, 4500 Espinho, Portugal
 Antonio Bernardo Correia de Amaral, Rua Julio de Lemos, 188 - 2º Dto, 4900 Viana do Castelo, Portugal
 António Jorge Souto Águeda da Costa, Travessa Campo Lindo, 141 - 1º, 4200 Porto, Portugal
 António José Gomes Teixeira, Rua Quinchosos, 48 - 2º Dtº, 5000 Vila Real, Portugal
 António Júlio Bernardes Antunes, Rua São Mamede, 13 - 5º Dto, 1100 Lisboa, Portugal
 António Leal Duarte, Dep. Matemática - Univ. Coimbra - Apartado 3008 , 3000 Coimbra, Portugal
 António Manuel Costa Almeida, Rua Central do Viso, 258, 4200 Porto, Portugal
 António Manuel Lopes Gonçalves, Rua Lavradeiras da Meadela, Lote 18 - 1º Esq., 4900 Meadela, Portugal
 António Vidal Santos, Urb. Bela Vista, Lote 15 - Ameijeira de Cima, 8600 Lagos, Portugal
 Augusto António César Cosme Franco, Praceta D. Jordão, 31 - 1º Dtº, 2530 Lourinhã, Portugal
 Branca Maria Araújo Silveira, Praceta de Avilhó, 16 - 1º Dto, 4460 Custóias - MTS, Portugal
 Cacilda dos Santos Paz, Quinta dos Reis, 2 - Vila Verde da Raia, 5400 Chaves, Portugal
 Camila Maria Antunes Carvalho, Rua Ernesto Carvalho, Edifício Turim - 5º A, 4760 Vila Nova de Famalicão, Portugal
 Cândida Maria de Almeida Queiroz Moreira, Av. Beira Mar, 1071, Ed.F, S/C Dto - Canidelo, 4400 V. N. Gaia, Portugal
 Carla Bernardete Delgado Josefino, Travessa 25 de Abril, 19 - Bugalhós - Mascotelos, 4810 Guimarães, Portugal
 Carla Maria Gonçalves de Macedo Moreira, Rua dos Congregados, 42 - 5º Dto, 4710 Braga, Portugal
 Carla Maria Lopes Domingues, Quinta do Rio - Gondizalves, 4700 Braga, Portugal
 Carlos Alberto Costa Própero, Beco do Arco, À Sé, 5, 8000 Faro, Portugal
 Carlos Alberto da Silva Vilar, Rua dos Congregados, 16 - 5º Dtº, 4700 Braga, Portugal
 Carlos Manuel Monteiro Correia de Sá, Rua Aval de Cima, 137 - 6º D, 4200 Porto, Portugal
 Carlos Montes Morais, Rua Bragas, 135 - 3º Dto, 4050 Porto, Portugal
 Carlos Valdemar Devesa Barroso, Rua 31 de Janeiro, 52, 4910 Vila Praia de âncora, Portugal
 Célia Maria Xavier e Sousa da Gama Lobo, Rua Pedro Nunes, 16, 4800 Guimarães, Portugal
 Cláudia Cristina do Caneiro Vasconcelos, Largo do Chafariz, 3475 Caramulo, Portugal
 Cláudia Cristina Pereira da Silva Oliveira, Rua Dr. Fernando Namora, Lote 27 - Bº Belo Horizonte, 2685 S. João da Talha, Portugal
 Cristina Loureiro, Rua São Mamede, 13 - 5º D, 1100 Lisboa, Portugal
 Cristina Maria Cruchinho da Fonseca, Rua da Boavista, 790 - 1º C, 4050 Porto, Portugal
 Cristina Maria da Silva Correia, Rua Padre Luis Portela, 15 - 2º Esq. - Maximinos, 4700 Braga, Portugal
 Darlinda Maria Pacheco Moreira, Largo Ana Castro Osório, 10 - 9º Dto, 2700 Amadora, Portugal
 Diamantina Ramalheite Ribeiro Carmona, Urb. Quinta do Mendes, Lote 119 - 3º Esq., 2675 Odivelas, Portugal
 Domingos Santos Rijo, Rua de S. Marcos, 35, 6000 Castelo Branco, Portugal
 Dulcínio José Parente Videira, Lugar Mesieiro - Oteiro, 4900 Viana do Castelo, Portugal
 Eduarda Maria Barbosa da Rocha, Padrões Meixomil, 4590 Paços de Ferreira, Portugal
 Eduardo M. S. S. Veloso, Av. D. Rodrigo da Cunha, 11 - 3º D, 1700 Lisboa, Portugal
 Elisabete da Fonseca Rodrigues, Rua D. João de Mascarenhas, 4 - 5º Esq - Damaia, 2720 Amadora, Portugal
 Elsa Cristina Pinho Duarte, Rua de Brancanes, 29 - C/V, 2900 Setúbal, Portugal
 Elsa Maria Santos Fernandes, Sítio da Igreja, 9135 Camacha, Portugal
 Elvira Maria Azevedo Mendes, R. Passos Manuel, 101 - 4º Esq., 1150 Lisboa, Portugal
 Elza Maria Alves de Sousa Amaral, Urbanização da Veiga, lote B1 - 3º Esq., 5000 Vila Real, Portugal
 Esmeraldina Maria Ganha de Sousa France Santos, Rua Belo Horizonte, 278 - 1º - S. Pedro da Cova, 4420 Gondomar, Portugal
 Estela Fernanda Domingues Vaz alves, Rua Beato Miguel de Carvalho, 138 - 2º, 4710 Braga, Portugal
 Eurico Nelson Coimbra Veloso da Veiga, R. Dr. Elísio de Moura, 28 - 1º Esq, 4710 Braga, Portugal
 F. R. Dias Agudo, Av. Salvador Allende 35, 2780 Oeiras, Portugal
 Fátima da Conceição Arruda G. Moura Esteves, Rua Nossa Senhora da Penha, 106 - Fajã de Cima, 9500 Ponta Delgada, Portugal
 Fátima Regina Duarte Gouveia Fernandes Jorge, Ur. Quinta da Granja, Lote 20 - 5º Frente, 6000 Castelo Branco, Portugal
 Fernanda Alice Martins e Mendes de Figueiredo, Rua Bonjardim, 959, 4000 Porto, Portugal
 Fernanda Belém Bessa de Sousa, Rua do Outeiro do Cabo, 161, 4580 Rebordosa, Portugal
 Fernanda Maria de Sousa Vieira, Rua de Cervantes, 39 - 1º Esq, 4050 Porto, Portugal
 Fernanda Maria Oliveira Dias de Andrade Alves, Rua do Fajal, 32 - 4º D, 4700 Braga, Portugal
 Fernanda Maria Tavares dos Santos, Quinta São João da Carreira - Frente à Betão Liz, 3500 Viseu, Portugal
 Floriano Augusto Veiga Viseu, R. Garcia de Orta, 114, 4710 Braga, Portugal
 Francisca Maria da Cunha Pereira Nascimento, Cerqueda - Delães, 4765 Riba D'Ave, Portugal
 Francisco de Assis Leite Silva, L. Tojais - Ponte, 4800 Guimarães, Portugal
 George Charle Krajcsik, Av da Republica 676 - 11º C, 4430 V. N. Gaia, Portugal

Guida Maria Pereira Gomes Andrade Dias, Rua Humberto Delgado, 27 - A - Canhoso, 6200 Covilhã, Portugal
 Guilherme de Sousa Belchior Vieira, Rua Quinta das Palmeiras, 102 - 1º Esq., 2780 oeiros, Portugal
 Helena Isabel Mariano de Sousa, Rua Fernão Alvares do Oriente, 8 - R/C Dto, 1700 Lisboa, Portugal
 Helena Isabel Ribeiro Lages Costa, Rua Cândido Beirante, 17, 4710 Braga, Portugal
 Helena Maria Cepeda Paradinha, Rua Lucília Simões, 5 - 4º Dto, 1500 Lisboa, Portugal
 Helena Maria Esteves Morais, Estrada Nova - Gualtar (Casa Brás), 4710 Braga, Portugal
 Helena Marisa dos Santos Pereira Gregório Romão, Av. Estados Unidos da América, 15 - Cave, 1700 Lisboa, Portugal
 Hélia Margarida Aparício Pintão de Oliveira, Casal de Ouressa, Lote 7 - 6º Dto, 2725 Mem-Martins, Portugal
 Henrique Inácio Pires Pereira, Praça da Paz, Acesso 4, 3º D, 8000 Faro, Portugal
 Hirondina Maria de Sá Afonso, Lugar de Saborido - Chafé, 4900 Viana do Castelo, Portugal
 Ilda Maria Maurício Rafael, R. Conde de Almoester, 90 10ºD, 1500 Lisboa, Portugal
 Inês Monteiro Barbedo de Magalhães, Travessa da Ferreira, 96 - 6º Esq., 4200 Porto, Portugal
 Irene Maria Bessa Marques, Tv. da Fábrica, 11, 4560 Penafiel, Portugal
 Isabel Cristina Almeida Lopes Filipe Colaço Dias, Torre 8 - 11 F, Torres da Bela Vista, Cidade Nova, 2670 Sto António dos Cavaleiros, Portugal
 Isabel Margarida Vasconcelos Couto Cardoso Garton, Rua do Jasmineiro, 9 - 1 D, 9000 Funchal, Portugal
 Isabel Maria Cardoso da Cruz Moreira Soares, Rua Mário de Almeida, 24 - 6º Esq, 4700 Braga, Portugal
 Isabel Maria Carvalho Torres Vieira, Rua de Silva Porto, 245 - 1º Esq., 4200 Porto, Portugal
 Isabel Maria Colim da Silva, Rua Cândido dos Reis, 8 - 2º Esq., 5100 Lamego, Portugal
 Isabel Maria da Cunha Catalão Dionísio Pires dos Santos, R. Dr. João de Barros, 19 - 2º Esq., 1500 Lisboa, Portugal
 Isabel Maria Damião Torres Costa, Rua da Junqueira, 3º Bairro, 1 - Vilar do Paraíso, 4405 Valadares, Portugal
 Isabel Maria Ferreira Martins Serra, R. Vitorino Nemésio, 8 - 4º Esq., 1750 Lisboa, Portugal
 Isabel Maria Reis Lopes Pinheiro, Rua Quinta da Armada, 112 - 1º Esq., 4710 Braga, Portugal
 Isabel Maria Rocha Pena, Rua Carlos Oliveira, 95 - 4º Esq., 4465 São Mamede de Infesta, Portugal
 Isabel Maria Serra Lopes, Rua Actor António Silva, 2 - 2º Dto - Venda Nova, 2700 Amadora, Portugal
 Isabel Maria Teixeira Barbosa, Edifícios Stª Luzia, Bloco 9 - Fração BG, 4600 Amarante, Portugal
 Isabel Maria Teixeira Ferreira da Costa, Rua José Afonso, Bloco 7, Lote B - 5º D.F., 4480 Vila do Conde, Portugal
 Isabel Salvador dos Santos, R. Vitorino Nemésio, 101 - 4º D, 4460 Senhora da Hora, Portugal
 Isilda Maria Gonçalves Fernandes Mano, Rua Óscar da Silva, 83 - 3º R, 4200 Porto, Portugal
 Jacinta Maria Fernandes Nogueira, Lugar de Fontelo, 4700 Fradelos, Portugal
 Jaime Maria Monteiro Carvalho e Silva, R. Virgílio Correia, Lote 13/13 - 4º Dto, 3000 Coimbra, Portugal
 Jesuina Isabel Lima dos Santos, Travessa da China, 141, 4300 Porto, Portugal
 Jesuína Rosa Raposo, Rua Poço do Passo, 12, 7050 Montemor-o-Novo, Portugal
 João Filipe Queiró, Dep. Matemática - Univ.Coimbra, 3000 Coimbra, Portugal
 João Manuel Baptista Rino, R. Poeta José Marques da Cruz, Lote 81 - 1º Dto, 2410 Cruz D'Areia - Leiria, Portugal
 João Manuel Caramalho de Melo Domingues, Rua São Roque da Lameira, 1812 - 1º Esq, 4300 Porto, Portugal
 João Manuel Casanova de Almeida, Av. Prof Dr. Augusto Abreu Lopes, 49 2º Esq., 2675 Odivelas, Portugal
 João Manuel Valente Nogueira, Rua Humberto Delgado, 55 - 3º F, 8000 Faro, Portugal
 João Pedro Mendes da Ponte, C. do Galvão, 21, 1400 Lisboa, Portugal
 Joaquim de Fontes Marques, Rua de Aldriz, 54, 4535 Argoncilhe, Portugal
 Jorge Luciano da Silva Carvalho, Rua Ernesto Carvalho, Edifício Turim - 5º A, 4760 Vila Nova de Famalicão, Portugal
 Jorge Manuel Bentes Paulo, R. Luis Antonio Vancy 10, 4710 Braga, Portugal
 José António da Silva Fernandes, Lugar de Mazagão, Lote 35 - R/C - Aveleda, 4700 Braga, Portugal
 José Augusto Coelho Lino Peres, Praceta da Rua de Moçambique, 66 - R/C Direito - Gandra, 4445 Ermesinde, Portugal
 José Carlos Coelho Campos, Lugar de Seixos Alvos - Areias S. Vicente, 4750 Barcelos, Portugal
 José Carlos T. de Oliveira, Travessa das Águas Livres, 31 - 1º E, 1200 Lisboa, Portugal
 José Miguel Rodrigues de Sousa, Trav. da Prova, 7 - 3º, 3530 Mangualde, Portugal
 Judite Ventura Conceição Monteiro Barbedo de Magalhães, Travessa da Ferreira, 96 - 6º Esq., 4200 Porto, Portugal
 Júlia Maria Teixeira Baptista, Rua Dr. João Antunes Guimarães, 22 - R/C Dto, 4710 Braga, Portugal
 Licínia Pereira Lima Brandão Costa, Rua Cerca, 409, 4150 Porto, Portugal
 Lídia Isabel Moreira da Silva Ferreira, Rua Pedro Ivo, 131 1ºDto, 4445 Ermesinde, Portugal
 Lucinda Alberta Teixeira Gomes, Urb. Sopete, Bloco 3A - 1º Dto, 4480 Vila do Conde, Portugal
 Luís dos Reis Morais, Urbanização Belo Zêzere, Rua A, Lote 126, 6200 Covilhã, Portugal
 Luís Filipe da Silva Reis, R. Monsenhor Manuel Marinho, 19, 4150 Porto, Portugal
 Luís Filipe dos Santos Roçadas Ferreira, Rua da Constituição, 1262 - 3º F, 4200 Porto, Portugal
 Luís Filipe Horta Cavalheiro, Rua do Barral, 72 - Meadela, 4900 Viana do Castelo, Portugal
 Luis Gonzaga Brandão Guerreiro, Rua S. Domingos, 108 - 1º Dto, 4710 Braga, Portugal
 Luisa Margarida Ferreira Pinto, Rua Filipa de Vilhena, 12, 4435 Rio Tinto, Portugal
 Manuel António Melo Alves, Trav. Dr. Francisco Machado Owen, 6 - Casa 15, 4710 Braga, Portugal

Manuel dos Santos Vaqueiro Machado, Quintas da Seara, 5300 Bragança, Portugal
 Manuel Fernandes da Cunha, Urb. Eng. Mário Valente, Casa 24, 4820 Fafe, Portugal
 Manuel Maria Brito Ferrari Almeida, Rua Bernardino Machado, 132 - Sra da Hora, 4460 Matosinhos, Portugal
 Manuela Valentina de Almeida e Sousa, R. D. António Bento Martins Júnior, 155-157, 4710 Braga, Portugal
 Margarida Maria Belchior Pereira Lopes, Av. D. Leonor Fernandes, 67, 7000 Évora, Portugal
 Margarida Maria Lobato Ferraz, R. 5 de Outubro, 103/b - 2º Esq., 4910 Vila Praia de Âncora, Portugal
 Margarida Paula Berquó de Aguiar Viveiros, Rua da Alegria, 82, 9500 Ponta Delgada, Portugal
 Margarida Rosa Damilão Torres Costa, Rua da Junqueira, 3º Bairro, 1 - Vilar do Paraíso, 4405 Valadares, Portugal
 Maria Alexandra de Oliveira Gomes, Rua Dr. Cartendo de Mena, 24 - 2º, 4430 Vila Nova de Gaia, Portugal
 Maria Alexandra Gomes dos Santos R. da Conceição, Rua de Egas Moniz, 227 - 1º, 4050 Porto, Portugal
 Maria Alexandra Oliveira Jutiga, Estrada de Brito, 516 - 1º Esq., 4405 Granja, Portugal
 Maria Alexandrina Figueiredo Vasconcelos Costa, Av. Lidador da Maia, 72 - Águas Santas, 4445 Ermesinde, Portugal
 Maria Amélia Oliveira e Silva Paraíso, Rua D. António da Costa, 19 - 3º Dto, 4700 Braga, Portugal
 Maria Assunção Santos Martins, Rua Bernardino Faria, 105, 4490 Póvoa do Varzim, Portugal
 Maria Augusta Leitão Bandeira Pires, Rua Mariano Pina, Lote 1509 - 12 C, 1500 Lisboa, Portugal
 Maria Augusta Pereira Alves Cardoso Lima, R. Cidade da Beira, 314, 4100 Porto, Portugal
 Maria Aurélia Silva Marques, Rua do Chantre, 14, 4470 Maia, Portugal
 Maria Bárbara de Sá Costa Reis Carvalho Araújo, Av. da Liberdade, 80 - 3º D, 4700 Braga, Portugal
 Maria Beatriz Rocha Barbosa, Rua D. Pedro V, 111 - 1º Esq., 4730 Vila Verde, Portugal
 Maria Cecília Preto Rebelo, Rua Dr. Virgílio Arruda, Lote 1 - 4º Esq., 2000 Santarém, Portugal
 Maria Cecília Rosas Pereira Peixoto da Costa, Rua da Lomba, 116, 4300 Porto, Portugal
 Maria Cristina Barros Alves Taveira, R. Fundação Calouste Gulbenkian, 145 - 5º Fr/Dto, 4710 Braga, Portugal
 Maria Cristina da Costa Vilhena Rodrigues, R. de Monsanto, 9 - 5º Esq. Trás, 4200 Porto, Portugal
 Maria Cristina Ferreira Martins, R. do Espírito Santo, 38/39 - 1º D - Nogueira, 4700 Braga, Portugal
 Maria da Assunção A. Rodrigues Coutinho, Rua Professor Machado Vilela, 170 - 1º - Ap. 6, 4710 Braga, Portugal
 Maria da Conceição Aires Queirós Antunes, Rua Cidade de Bolama, 7 - 6º Esq., 1800 Lisboa, Portugal
 Maria da Conceição Bento de Almeida Coelho, Rua Hernâni Torres, 39 - 2º Esq., 4200 Porto, Portugal
 Maria da Conceição Saldanha Sousa P. Barroso Alves, Rua Bento Junior, 117 - 2º Esq., 4200 Porto, Portugal
 Maria da Glória Ribeiro Ferraz, Loteamento Campo Margarida, Lote 2 - Recta de Gualtar, 4700 Braga, Portugal
 Maria da Graça Costa Silva Prima de Sousa, Av. Mousinho da Silveira, 52 - 3º Esq. - Queijões, 4470 Maia, Portugal
 Maria da Graça Guimarães Medina, R. Martim Moniz, 95 - 1º, 4100 Porto, Portugal
 Maria da Graça Tarujo Braga da Cruz, Largo Almeida Garrett, 32B - 1º H, 3880 Ovar, Portugal
 Maria da Luz Esperança Duarte, Urb. Portela, Lote 196 - 10º D, 2685 Sacavém, Portugal
 Maria da Luz Rodrigues Jardim e Rino Peres, Rua T. Coronel Sarmento, Núc. Resid. Ilhéus, 2º F, 9000 Funchal, Portugal
 Maria de Fátima Coelho de Sousa Ribeiro, Rua de Requesende, 150 - R/C, 4200 Porto, Portugal
 Maria de Fátima Lima Tavares, Rua Alfredo Vaz Pinto, 4540 Arouca, Portugal
 Maria de Fátima Pereira Barbosa Mendes de Seça, Rua Professor Bento de Jesus Caraça, 19, 1600 Lisboa, Portugal
 Maria de Fátima Pereira Cirne Graís, Praceta Bento de Jesus Caraca, 14-1º Esq., 2000 Santarém, Portugal
 Maria de Fátima Ramos Pinheiro, R. Álvaro Castelões, 622 - 1º Esq., 4200 Porto, Portugal
 Maria de Lurdes Machado da Silva Marques, Rua Comandante Carvalho Crato, BC C - 3º F, Caldas das Taipas 4800 Guimarães, Portugal
 Maria do Carmo Campos Lopes, Rua Carlos Teixeira, 19 - 3º Centro, 4710 Braga, Portugal
 Maria do Carmo Coelho Loureiro Cardoso, R. Cidade do Recife, 152 - 8º B, 4200 Porto, Portugal
 Maria do Carmo Garcia Sena Neves, R. Barão de Sabrosa, 31 - 1º Esq., 1900 Lisboa, Portugal
 Maria do Carmo Oliveira Santos, R. Padre João Caetano Flores, 1 - Ribeira Chã, 9560 Lagoa - S. Miguel, Portugal
 Maria do Carmo Senra Campelo M. Pereira, Rua Monsenhor Ferreira, 400 - 3º Dto, 4710 Braga, Portugal
 Maria do Céu Carvalho da Silva, Covide Fajaco, 4840 Terras de Bouro, Portugal
 Maria do Céu Henriques David, Rua da Figueirinha, 1 - 1º Dto, 2780 Oeiras, Portugal
 Maria do Céu Pereira da Silva, R. Henrique de Medina, 159 - 3º Dto, 4200 Porto, Portugal
 Maria do Rosário Ferreira da Silva, Rua Gomes de Amorim, 120 - 1º Centro, 4490 Póvoa do Varzim, Portugal
 Maria do Rosário Machado Lema Sinda Pinto, Rua Dr. Mário Vasconcelos Sá, 13 - 5º Dto, 4050 Porto, Portugal
 Maria do Rosário Monteiro, Praceta Dr. Sá Carneiro, 121 - 2º D, 4415 Perosinho, Portugal
 Maria do Rosário Moreira de Matos Valério, Rua de Santa Catarina, 1185 - 3º, 4000 Porto, Portugal
 Maria do Rosário Paulino Branco Ribeiro Almeida, Largo Conde de Ottilirei, 16 - 3º Esq, 1500 Lisboa, Portugal
 Maria do Sameiro Carneiro Ribeiro, Lugar de Bagães, 4830 Póvoa de Lanhoso, Portugal
 Maria Edite Marques dos Santos Brás Simões do Rosário, Rua da Quinta Grande, 8 - R/C, 2780 Oeiras, Portugal
 Maria Eduarda Moura, Rua José Santos Ramos, 274, 4470 Gueifães, Portugal
 Maria Elisa de Lima Mirra, R. Banda Marcial de Gueifães, 261 - 5º Esq. - Guifães, 4470 Maia, Portugal
 Maria Elisabete Videira Lopes, Rua dos Congregados, 10 - 2º Esq., 4710 Braga, Portugal
 Maria Emília Alves Rodrigues da Silva, Rua Dr. Manuel Monteiro, 37 - 2º dto, 4710 Braga, Portugal

Maria Fernanda de Oliveira Gonçalves Estrada, Rua Martins Sarmiento, 98 - 2º, 4710 Braga, Portugal
 Maria Fernanda Gonçalves da Cunha, Lugar da Póvoa - Palmeira, 4700 Braga, Portugal
 Maria Florbela do Couto Vieira, Rua Fundação Gulbenkian, 131 - 3º Dto, 4710 Braga, Portugal
 Maria Gabriela Barbosa Rodrigues Armelino, Rua 36, 1002 - 1º Dto, 4500 Espinho, Portugal
 Maria Gabriela Gerales Xavier Nunes, R. General Humberto Delgado, 16 - 1º Dtº, 7000 Évora, Portugal
 Maria Gabriela Hormigo Nunes Pernes de Aguiar, Rua Professor Reinaldo dos Santos, 7 - 9º Dto, 1500 Lisboa, Portugal
 Maria Gertrudes de Sá Soares de Oliveira, Rua Dr. António Sampaio Maia - S. João de Vêr, 4520 Sta Maria da Feira, Portugal
 Maria Gracelina Matos de Boaventura, Lugar da Igreja Velha - Balugães, 4905 Barroscelas, Portugal
 Maria Graziela Esteves de Carvalho Fonseca, R. Damião de Góis, 446 - 4º Esq., 4050 Porto, Portugal
 Maria Guilhermina Pereira Carvalho Nogueira, Rua Cactano de Melo, 311 - 3º Dtº - Oliveira do Douro, 4430 Vila Nova de Gaia, Portugal
 Maria Guilhermina Pinto dos Santos Monteiro de Barros, R. Sá de Miranda, 171, 4700 Braga, Portugal
 Maria Helena Borges Costa Martins, R. Marta Mesquita Câmara, 127 - 3º B, 4150 Porto, Portugal
 Maria Helena Branco Barreiros Lopes da Silva, R. Prof. Bento J. Caraça, 189 - 7º - Hob 71, 4200 Porto, Portugal
 Maria Helena da Silva Almeida, R. Luis Barroso, Ed. Infante D. Henrique, Bloco B, 4760 Vila Nova de Famalicão, Portugal
 Maria Helena dos Santos Coelho, Praça da Missilva, 30 - 1º Dtº, 4435 Rio Tinto, Portugal
 Maria Helena Fernandes Torres, Av. da República, 91 - 1º Dto - Algés, 1495 Lisboa, Portugal
 Maria Helena Guimarães Couto Tavares, R. Dr. Eduardo Santos Silva, 180 - 2º D, 4200 Porto, Portugal
 Maria Helena Lopes de Oliveira, Av. da Liberdade, 219 - 6º - Casa 6, 4700 Braga, Portugal
 Maria Helena Monteiro Fidélis, R. Pedro Franco, 25 - 2º Esq., 2700 Amadora, Portugal
 Maria Helena Santos de Oliveira e Cunha, Rua Dr. Azeredo Perdigão, Bloco 5A - 2º Esq., 3500 Viseu, Portugal
 Maria Helena Silva de Sousa Martinho, Rua Luís António Verney, 31, 4710 Braga, Portugal
 Maria Idalina Lourido Figueiredo dos Santos, R. Fonte dos Arrepêditos, 330 - 4º Esq., 4430 Gaia, Portugal
 Maria Inês Almeida Azevedo Gama Alegria, Rua Professor João Barreira, 3 - 1º Esq., 1600 Lisboa, Portugal
 Maria Isabel A. R. Silva Lopes, R. João Lúcio de Azevedo, 53 - 5º Frente, 4200 Porto, Portugal
 Maria Isabel Baccelar Nunes da Cruz, R. Sabrosa, 71 - 9º Esq., 4300 Porto, Portugal
 Maria Isabel Quinta Santos, Rua Lugarinho, 52 - 2º D, 4200 Porto, Portugal
 Maria Isaura Fazendeiro Mendes Raposo, Avenida 5 de Outubro, Ed. 3 - 3º Esq., 6200 Tortosendo, Portugal
 Maria Ivete Pinto de Azevedo, Apartado 130, 4435 Rio Tinto, Portugal
 Maria João Duarte Lopes da Conceição Fortunato, Avenida da Liberdade, 4 - 7º D, 2745 Queluz, Portugal
 Maria João Furtado Rita Lagarto, Av. D. Sebastião, 38 - 1º Esq., 2825 Costa de Caparica, Portugal
 Maria Joaquina da Silva Gonçalves Maciel, Rua Nicolau Marques Guedes, 109 - 2º Frente, 4200 Porto, Portugal
 Maria José Azevedo Moura Cruz, R. do Raio, 363 - 3º, 4710 Braga, Portugal
 Maria José de Oliveira Tavares Mendes da Costa, R. Chaby Pinheiro, 183, 4450 Senhora Da Hora, Portugal
 Maria José Freitas Lima Soares, Torrogelo - São Mamede de Negrelos, 4780 São Martinho Campo, Portugal
 Maria José Marques Carapinha, R. Rodrigues Lobo, 57 - 2º D/F, 4150 Porto, Portugal
 Maria José Marques Veiga, Al. António Sérgio, 80 - 1º Dto, 2795 Linda-a-Velha, Portugal
 Maria José Pinheiro Gomes Ribeiro, Lugar do Vau - Sequeira, 4700 Braga, Portugal
 Maria Júlia Abóbora Torres, Av. Eng. Pereira Caldas, 66 - A, 2985 Pegões Velhos, Portugal
 Maria Júlia de Oliveira Ferreira, Rua Álvaro Aurélio Céu Oliveira, 63, 4470 Maia, Portugal
 Maria Laura Leitão Guerra, R. Ponte D'Ave, 953 - Macieira, 4480 Vila do Conde, Portugal
 Maria Leonor de Paiva Filipe, R. Públia Hortênsia Castro, 3 - 6º A, 1500 Lisboa, Portugal
 Maria Leonor dos Santos Gradíssimo da Cunha, Rua Carlos Dubini, 46 - 3º Dto, 4150 Porto, Portugal
 Maria Lídia Tormenta Bastos Calvário Clemente, Rua do Campo, Ed. NGAN FAI, 17º F, Macau, Macau
 Maria Lúcia da Silva Figueiredo, Rua Valério Peixoto de Sá, 21 - 1º Esq. - Real, 4700 Braga, Portugal
 Maria Lúcia Fernandes Alves, Subdeveza - Vale, 4970 Arcos de Valdevez, Portugal
 Maria Luisa Alves Martins, Av. da Liberdade, 158 - 6º Dto, 4710 Braga, Portugal
 Maria Luisa Pires Monteiro, Campo Redondo - Rua C, 2, 5300 Bragança, Portugal
 Maria Madalena Azevedo Faria, Rua Fonte da Torre, 103 - Retorta, 4480 Vila do Conde, Portugal
 Maria Manuela Coimbra Ferreira Fonseca, Rua dos Gisantemos, 313 - Vale Ferreiros - Fânzeres, 4420 Gondomar, Portugal
 Maria Manuela Mota Faria da Conceição, Casal do Chapim, Lote 18 - 11º C, 2675 Odivelas, Portugal
 Maria Margarida Leal Silva Ribeiro, R. Simões de Almeida, 7, 4710 Braga, Portugal
 Maria Margarida Paiva Atayde, Rua da Piscina, 17 - 14º Esq - Miraflores, 1495 Lisboa, Portugal
 Maria Margarida Teixeira Martins, Rua João Pedro Ribeiro, 937 - 2º Esq., 4100 Porto, Portugal
 Maria Margarida Trindade Salgado de Oliveira, Av. Visconde Valmar, 9 - 1º Esq., 1000 Lisboa, Portugal
 Maria Matilde Couto Vieira Carvalho, R. Fundação Gulbenkian, 131 - 3º Dto, 4710 Braga, Portugal
 Maria Natália Coutinho Galvão Dias, Av. Baltazar do Couto, 312, 4480 Vila do Conde, Portugal

Maria Olímpia Gomes Máximo, Av. D. Luís I, 21 - 2º Esq., 2720 Alfragide, Portugal
 Maria Olívia Oliveira de Sousa, Quinta do Junqueiro, Lote 26 - 2º Esq., 2775 Carcavelos, Portugal
 Maria Otilia Fonseca Melo e Faro, Rua Martins Sarmiento, 40 - 3º, 4200 Porto, Portugal
 Maria Otilia Monteiro Moreirinha, Praceta Carolina Simões, 1 - 2º Esq., 2700 Amadora, Portugal
 Maria Paula Abrantes de Teixeira Rebelo, Rua de Lima Júnior, 20 - 3º E, 4200 Porto, Portugal
 Maria Rosa Gomes Santos Ferreira Rebelo, Vendas - Cruz, 4760 Vila Nova de Famalicão, Portugal
 Maria Rosalina Azevedo Natal, Rua dos Burgães, 48, 4050 Porto, Portugal
 Maria Rosete da Rocha Pinho Moreira, Est. Int. da Circunvalação, 15053, 4100 Porto, Portugal
 Maria Silvina Aguilar de Freitas Monteiro, Rua Conselheiro Fonseca, 122 - 2º E, 4405 Vilar do Paraíso, Portugal
 Maria Teresa Barandela Meireles Neves, Rua Nove de Abril, 634 - 6º, 4200 Porto, Portugal
 Maria Teresa Calarrão de Oliveira Colaço, R. Aquiles Machado, 8 - 5º Dto, 1900 Lisboa, Portugal
 Maria Teresa Cerqueira da Silva, Rua José A. Leite, 8, 4720 Amares, Portugal
 Maria Teresa de Jesus de Castro Dias Martins Vicente, Rua Marquês de Soveral, 7 - 7º Esq., 1700 Lisboa, Portugal
 Maria Teresa Dias Soeiro Cordeiro, Pr. Condestável, 70 - 1º Esq, 4700 Braga, Portugal
 Maria Teresa Santos Barquinha Branco Teixeira, R. Barão do Corvo, 628 - 4º T, 4400 Vila Nova de Gaia, Portugal
 Maria Teresa Vaz de Moura Viegas, Rua Aval de Cima, 137 - 6º D, 4200 Porto, Portugal
 Maria Zaida Morais Oliveira Marques Guimarães, Rua 28, 212, 4500 Espinho, Portugal
 Maria Zélia Almeida Pinto Bilhoto, Boavista - S. Tiago da Cruz, 4760 Vila Nova de Famalicão, Portugal
 Maria Zita Marques Guerra, Rua Gonçalves Zarco, 6 - 5º Esq, 1400 Lisboa, Portugal
 Mário José Batista Maia, Tv. da Pereira, 14 - 1º Esq., 1170 Lisboa, Portugal
 Mário José Pimenta Roque de Oliveira, Av. D. João IV, 1582 - 1º A, 4810 Guimarães, Portugal
 Marisa de Fátima da Silva Morgado, Rua de Abril, Lote 12 - Penouços - Fraião, 4710 Braga, Portugal
 Mercedes Elisabeth Vieira do Vale Matta de Almeida, R. Prof. Reinaldo dos Santos, 19 - 5º Dto, 1500 Lisboa, Portugal
 Natércia Maria Fernandes Soares, Urb. Bela Vista, Lote 9 - Subcave Direita, 3040 Coimbra, Portugal
 Noémia de Jesus Miranda, R. Professor Sousa da Câmara, 193 - 1º Esq., 1070 Lisboa, Portugal
 Nuno Miguel Ramos Valério, Rua Aviação, 6 R/C Dto, 2615 Alverca, Portugal
 Olga Manuela Lopes Barbosa, Rua Martim Moniz, 7 - 2º D, 4720 Amares, Portugal
 Olga Maria Costa Dias de Freitas, Rua Carne Azeda, 15 - 1º B - Bloco I, 9050 Funchal, Portugal
 Olga Maria Vaz Moreira, Rua dos Congregados, 28 - 4º Esq., 4710 Braga, Portugal
 Paula Alexandra de Sousa Teixeira, Lugar da Lameira - Barreiros, 4720 Amares, Portugal
 Paula Cristina Miranda de Oliveira Madeira, Rua Raul Caldevilla, 59 - 3º Dto, 4200 Porto, Portugal
 Paula Cristina Soares Cunha Novais, Rua José Ribeiro Vieira da Castro, 671, 4820 Fafe, Portugal
 Paulo Alexandre de Jesus Oliveira, Casal de Ouressa, Lote 7 - 6º Dto, 2725 Mem-Martins, Portugal
 Pedro Manuel Baptista Palhares, Rua Cândido dos Reis, 34 - 2º, 4900 Viana do Castelo, Portugal
 Raquel Maria Ruivo Crespo Ferreira Escórcio, Largo Samuel Diniz, 4 - 4º Esq, 1500 Lisboa, Portugal
 Raul Aparício Gonçalves, Rua D. Pedro IV, 271 - R/C Dto, 4440 Valongo, Portugal
 Rogério Conceição Bacalhau Coelho, R. Carvalho Araújo, 22, 8000 Faro, Portugal
 Rosa Maria Aroso da Costa Maia Farinha Ribeiro, Rua 16, 65 - Urbanização do Lídaror, 4470 Maia, Portugal
 Sandra Elisabete Rodrigues Vilela, R. Dr. José Sousa Machado, 42 - 2º, 4710 Braga, Portugal
 Sara Maria Limão Gata de Amaral Rodrigues Barbosa, Casa dos Lagos, Bom Jesus, 4700 Braga, Portugal
 Seila Isabel Freitas Oliveira, Av. Antero de Quental, 43 - 4º Dto, 4710 Braga, Portugal
 Sónia Isabel Pereira Ramos Teixeira, Rua Cónego Manuel Faria, 304 - 5º Esq., 4700 Braga, Portugal
 Sónia Maria Oliveira Portela, Rua D. Pedro IV, 271 - R/C Dto, 4440 Valongo, Portugal
 Sónia Martins Félix, Rua Instituto Conde de Agrolongue, 23 - R/C A, 2780 Paço de Arcos, Portugal
 Susana Cristina Sacramento de Castro, Agra do Moinho - Burgães, 4780 Santo Tirso, Portugal
 Susana Maria da Silva Araújo, Rua das Forças Armadas, 93, 4710 Braga, Portugal
 Teresa Cristina Ferreira da Silva, Av. Valério Pinto Sá, 63 - Dume, 4700 Braga, Portugal
 Teresa de Jesus Costa Pereira Caracol Caetano, R. Timor, Lote 129 - 3ºD - Olival Basto, 2675 odivelas, Portugal
 Teresa Dias de Azeredo, R. Dr. Conego António José Ribeiro, nº22 R/C Dto frente, 4700 Braga, Portugal
 Teresa Maria Cerveira Furtado, Rua Américo Ferreira de Carvalho, 50 - 2º Dto, 4710 Braga, Portugal
 Teresa Maria Martins Evaristo Monteiro, Rua Dr. António Ramos de Almeida, 206, 4480 Vila do Conde, Portugal
 Teresa Paula Gonçalves Teixeira Dias, Trav. Maria da Fonte, 5 - Esgueira, 3800 Aveiro, Portugal
 Tina da Conceição Marques Soares Ribeiro Gregório, Rua Joaquim Leitão, 48 - 1º Dto, 4100 Porto, Portugal
 Virginia Maria Abrantes Amaral, P. Gomes Eanes de Azurara, Lote 197 - 1º C - Massamá, 2745 Queluz, Portugal
 Vitor Manuel Dias Rodrigues, Lugar de Almoinha - Lamas, 4700 Braga, Portugal
 Vitor Rui Hortas Mendes Reis, R. Vitorino Nemésio, 101 - 4º D, 4460 Senhora da Hora, Portugal
 Vladimiro Sérgio de Sousa Machado, R. José Joaquim Ribeiro Teles, 306, 4445 Ermesinde, Portugal
 Zilda Dias de Oliveira Garcia da Rocha, Av. da Liberdade, 80 - 6ºD, 4710 Braga, Portugal
 UK
 Andrew Croudace, 10, Francis Court, Cranes Park, Surbiton, KT5 8BU Surrey, UK
 David Whiteley Lingard, 163, Watt Lane, Sheffield, S10 5RD, UK

Emily Walsh, 18, Banks Avenue, Orrell, Wigan, WNS 8HU Manchester, UK
Geoff Sheath, 17a, Cantwell Road, SE18 London, UK
John Fauvel, Mathematics Faculty, The Open University, MK7 6AA Milton Keynes, UK
June Barrow-Green, Fac. of Maths & Computing, The Open University - Walton Hall, MK7 6AA Milton Keynes, UK
Kevin Spratt, 134 Highview, Vigo, Meopham, DA13 OTQ Kent, UK
Leo F. Rogers, Digby Stuart College, Roehampton Institute London, SW15 5PH London, UK
Muriel Seltman, 15, Messeter Place, Eltham, London, SE9 5DP, UK
Neil Leonard Bibby, Via del Ricordo, 2, 20128 Milano, Italia
Philip Charles Gager, 22 Elmwood Gardens, Lancaster, LA1 4PG, UK
Robin J. Wilson, 15, Chalfont Road, OX2 6TL Oxford, UK
Stella Mills, 110, Foley Road West, Steetly, Sutton Coldfield, B74 3NP, UK
Wendy Tray, 40 Pagoda Gardens, SE3 OUX London, UK
Wendy Withycombe, 23, West Way, Pembury, Tunbridge Wells, TN2 3EX Tunbridge Wells, UK

Roumanie

Liviu Sofonea, Universitates Transilvania, Brasov, B-dul Eroilor 20, , 2200 Brasov, Roumanie

Sweden

Anna Ingegard Lothmar, Flootgatan, 13, 65471 Karlstad, Sweden
Annika Lindgren, Nordgatan, 12, S-67140 Arvika, Sweden
Elin Thompson, Ulysbygatan 2B, 1TRP, S-65464 Karlstad, Sweden
Lars-Eric Bjork, Krokvangen, 10, S-34135 Ljungby, Sweden
Maria Wase, Seminariegatan, 11, S-65229 Karlstad, Sweden
Sara Bohlin, Jarnvagsatan, 36, S-67131, Sweden
Stig Hakangard, Pimpstensv, 2, S-65350 Karlstad, Sweden

Taiwan

Wann-Sheng Horng, Math Dept. NTNU, 88 Sec 4, Tinchow Road, 117 Taipei, Taiwan

The Netherlands

Anko Haven, Van Diemenstraat 45, 3531 GG Utrecht, The Netherlands
Barbara Elzer, Nieuwegracht, 153 - Utrecht, 3512 LL, The Netherlands
Harm Jan Smid, Fac. T.W.I. Mekelweg 4, Delft, 2628 CD, The Netherlands
Hermien Eigeman-Brunt, Tamarastraat, 21 - Culemborg, 4105 GE, The Netherlands
Jan van Maanen, University of Groningen, Dep. of Mathematics - P.O. Box 800, 9700 AV Groningen, The Netherlands
Janna Harmina Raterink, Fie Crelsenlaan, 38, 3584 GK Utrecht, The Netherlands
Lambrecht Spykerboer, Theo Dobbhof, 40, 3762 XS Soest, The Netherlands
M. G. Koen M. Pillot, Postelstraar 6, Esch, 5296 LN, The Netherlands
Marjolein Kool, Jonkheer Ramweg, 28B, NL - 3998 JR Schalkwijk, The Netherlands
Maurice Scheren, Vesunius, 108, 3521 WX Utrecht, The Netherlands
Peter J. G. Lorist, J. vd. Borchstraat, 15, 3515 XA Utrecht, The Netherlands
Pieter T. Lanser, Simón Bolívarstraat, 91, 3573 ZK Utrecht, The Netherlands

USA

Betty B. Reiter, 5827 Beckett Court, Charlotte, N C 28211, USA
Charles Jones, Dep. of Mathematical Sciences, Ball State University, Muncie, Indiana 47306-0490, USA
Dorothy Jeanne Goldberg, 18, Woods Hole Road, Cranford N.J. 07016-1711, USA
Edward C. McClew Jr., 203, South Glengarry Road - Bloomfield Hills, MI 48010, USA
Florence Fasanelli, 1529 18th St. NW, 20036 Washington D.C., USA
Frank Joseph Swetz, 616, Sandra Ave, 17109 - Harrisburg, PA, USA
Gary Brown, HAB Building, College of Saint Benedict, St. Joseph, 56374 Minnesota, USA
George Winfield Heine III, 200 Sunset Lane, Pueblo, CO, 81005, USA
James F. Kiernan, 443, 12st - Apt 3F, Brooklyn, New York 11215, USA
Janet Heine Barnett, 200 SunSet Lane, Pueblo, Colorado, CO 81005, USA
John Barnes Chapman, Dept. Of Mathematics, Southwestern University, Georgetown, Texas 78626, USA
Mary Sue Houston, 7052 Ivy Hill Drive, Warrenton, VA 22186, USA
Michael H. Millar, Dept. of Maths - University of Northern Iowa, 50614-0506 - Cedar Falls - Iowa, USA
Phillip Eugene Johnson, Math/Science Center, UNC Charlotte, 28 223-0001 - Charlotte, NC, USA
Sara Mastellone, 33, Stephen St. Montclair, 07042 New Jersey, USA
Sylvia Lazarnick, RD 1 - Box 2120, Fairfield, VT 05455 - 9733, USA
V. Frederick Rickey, Dept. Of Mathematics & Statistics, Bowling Green State University, Bowling Green, OH 43403-0221, USA
Victor J. Katz, 841, Bromley St - Silver Spring, 20902 MD, USA
William D. Austin, Jr., 4103 Devine St. Apt. J-5, 29205 Columbia, SC, USA

Zimbabwe

Anthony Gavin Hitchcock, Department of Mathematics - University of Zimbabwe, PO BOX MP167, Zimbabwe

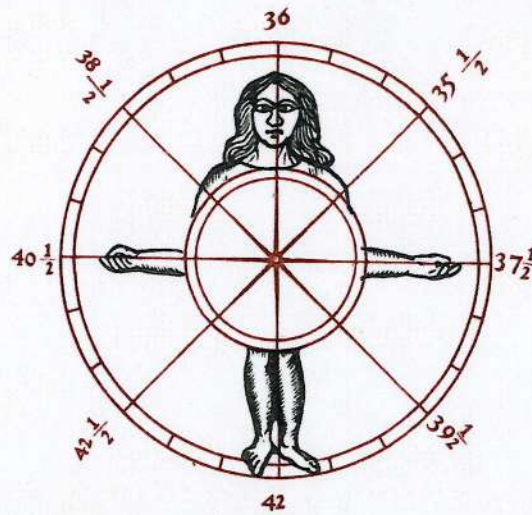

In the beginnings of astronomical navigation in the Atlantic, Portuguese pilots used this wheel to estimate their distance in latitude from Lisbon. The figure represents a man in the sky, facing us, with the centre of the body on the North Pole of the celestial sphere. It was a visual aid to define eight directions on the sky: head (North), left shoulder (Northeast), left arm (East), left foot (Southeast), feet (South), etc.. The numbers around the wheel give Polaris altitude in Lisbon when the front guard (star Kochab of Lesser Bear) is on that direction. The pilots compared this value with Polaris altitude in another place to compute the difference in latitude and transform it into distance in leagues. The figure appears in the book *Reportório dos Tempos*, by Valentim Fernandes, ed. 1518.

Cette roue était utilisée par les navigateurs portugais, dans les débuts de la navigation astronomique sur l'Atlantique, pour déterminer la distance en latitude de Lisbonne. La figure représente un homme dont le centre du corps est sur le pôle boréal. C'est un aide visuelle pour définir des directions sur le ciel: tête (Nord), épaule gauche (Nord-est), bras gauche (Est), pied gauche (Sud-est), pieds (Sud), etc. Les numéros autour de la roue donnent les hauteurs de l'Étoile Polaire à Lisbonne quand l'étoile Kochab de la Petite Ourse est dans cette direction. Les navigateurs comparaient ces valeurs avec les hauteurs de la Polaire dans un endroit différent pour calculer la distance en latitude par rapport à Lisbonne et la transformer en lieues. La figure se trouve dans le livre *Reportorio dos Tempos*, de Valentim Fernandes, ed. 1518.

Esta roda foi usada pelos navegadores portugueses, no início da navegação astronómica no Atlântico, com o fim de determinar a distância a Lisboa, em latitude. A figura representa um homem, com o centro de corpo sobre o Pólo Norte celeste. Trata-se de uma ajuda visual para definir direcções no céu: cabeça (Norte), ombro esquerdo (Nordeste), braço esquerdo (Este), pé esquerdo (Sudeste), pés (Sul), etc. Os números em torno da roda são as alturas da Polar em Lisboa quando a guarda dianteira da Ursa Menor (Kochab) está na respectiva direcção. Os pilotos comparavam estes valores com os obtidos num outro ponto, determinavam assim a diferença em latitude em relação a Lisboa e transformavam esta diferença em léguas. A figura está incluída no livro *Reportório dos Tempos*, de Valentim Fernandes, ed. 1518.

Bibliografia:

Albuquerque, Luis de, *Astronomical Navigation*, Comissão Nacional para as Comemorações dos Descobrimentos Portugueses, 1988.